

# E.ADEM v0.0.5.5

*E. coli* Automatic Directed Evolution Machine ?

or

*E. coli* Adaptive Directed Evolution Machine ?

2009.9.12

2009.5.3

131 days

2009.9.12

47 days

2009.10.30

## Calendar of Events

### IGEM 2009 Calendar of Events

**Note:** Dates in grey have not been finalized yet. Make sure to check the calendar periodically for any changes!

- 19 February** IGEM 2009 registration opens
- 31 March** IGEM 2008 registration closes; Team registration fee due
- 13 May** DNA Distribution sent to teams (**target deadline; subject to change**)
- 16/17 May** [iGEM Workshop, MIT, USA](#)
- 1 June** [Visa invitation letter requests due](#)
- 20/21 June** [iGEM Workshop, Europe](#)
- 27/28 June** [iGEM Workshop, Asia](#)
- 15 June** Preliminary team rosters due
- 1 August** Team project descriptions due
- 18 September** [Jamboree attendance fee due](#)
- 18 September** [Request for variance](#) due (notice and description of any use of non-standard parts or devices schemes due)
  - [Track selection](#) due
  - [Project abstracts](#) due
  - [Team rosters](#) due
- 21 October** Project and part documentation due, including documentation for all medal criteria
  - BioBrick Part DNA needs to be received by the Registry
  - [Judging form](#) due
  - Wiki FREEZE at 11:59pm, EST
- 30 Oct - 2 Nov** iGEM Competition Jamboree, MIT, USA

# Assembly

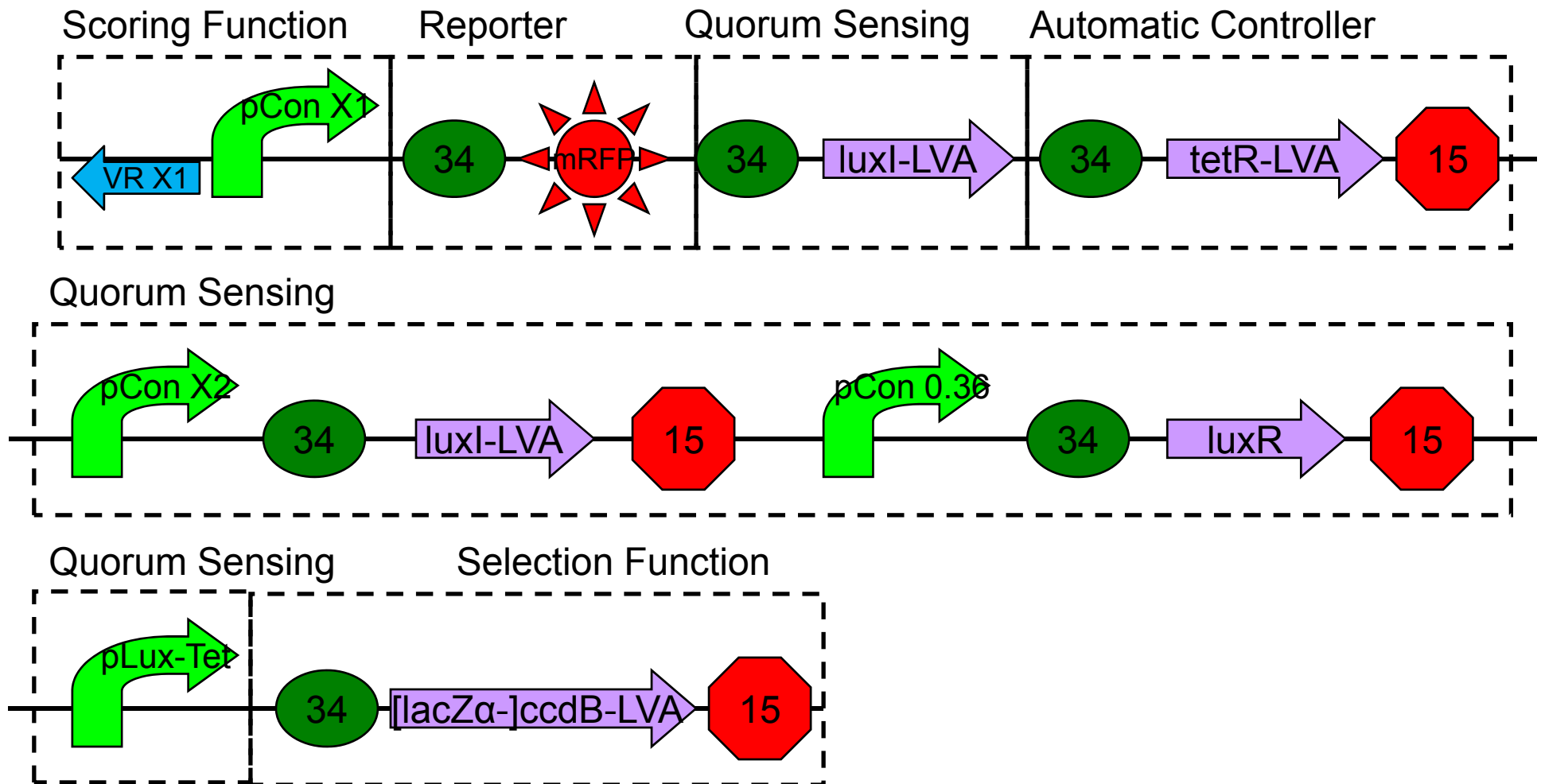

1. pLux-Tet
2. pLux-Tet + GFP
3. pCon  $\times$  4 + luxR + pLux-Tet
4. ccdB  $\times$  8
5. pCon  $\times$  8
6. pCon  $\times$  8 + GFP
7. pCon + luxR
8. pCon  $\times$  7 + luxI (AHL detection by 9)
9. pCon + luxR  $\times$  4 + pLux-Tet + GFP (AHL)
10. pCon + luxR  $\times$  4 + pLux-Tet + ccdB  $\times$  8 (AHL)
11. tetR  $\times$  2
12. tetR  $\times$  2 + pCon  $\times$  2 + luxR + pLux-Tet [+ GFP]
13. pCon  $\times$  4 + tetR  $\times$  2 + pCon  $\times$  2 + luxR + pLux-Tet [+ GFP] (AHL/aTc)
14. [pCon  $\times$  7 +] luxI + pCon  $\times$  2 + luxR + pLux-Tet [+ ccdB  $\times$  8 | + GFP]
15. VR  $\times$  10
16. (VR + pCon)  $\times$  7
17. tetR + pCon + luxI + pCon + luxR + pLux-Tet [+ ccdB]
18. [mRFP +] luxI + tetR + pCon + luxI + pCon + luxR + pLux-Tet [+ ccdB]
19. (VR + pCon)  $\times$  6 + tetR + pCon + luxI + pCon + luxR + pLux-Tet [+ ccdB]
20. (VR + pCon)  $\times$  6 + mRFP + luxI + tetR + pCon + luxI + pCon + luxR + pLux-Tet [+ ccdB]

Delayed  
Waiting  
Working  
Done  
Sequenced

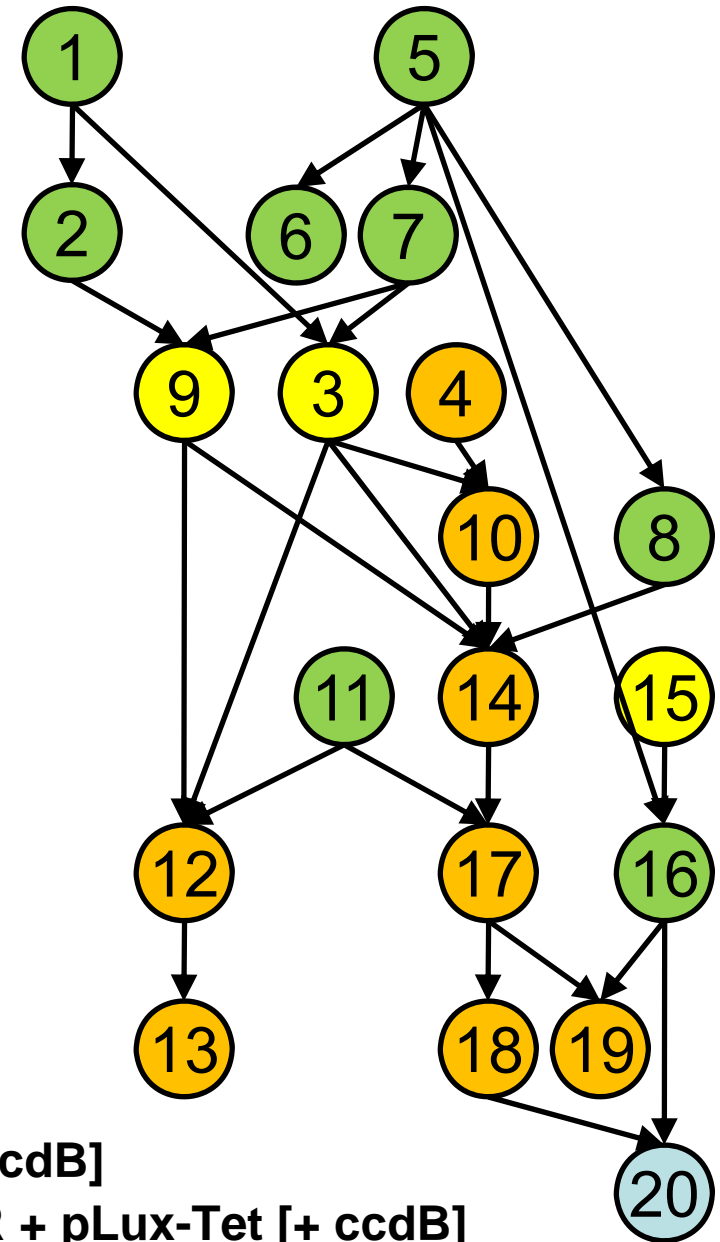

### Evolution Object

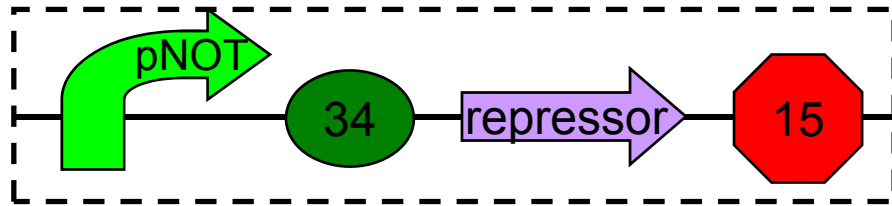

### Scoring Function

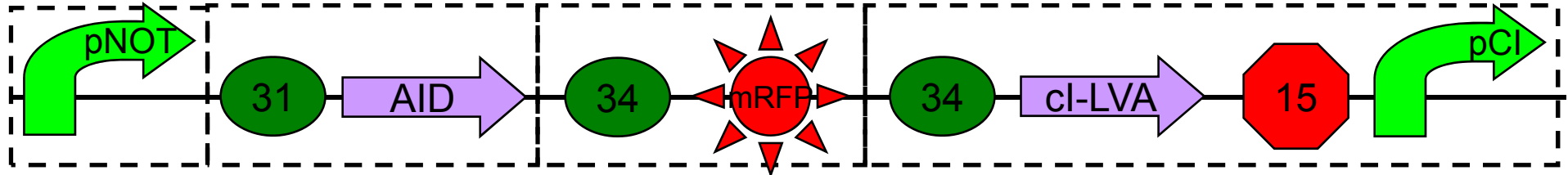

### Quorum Sensing

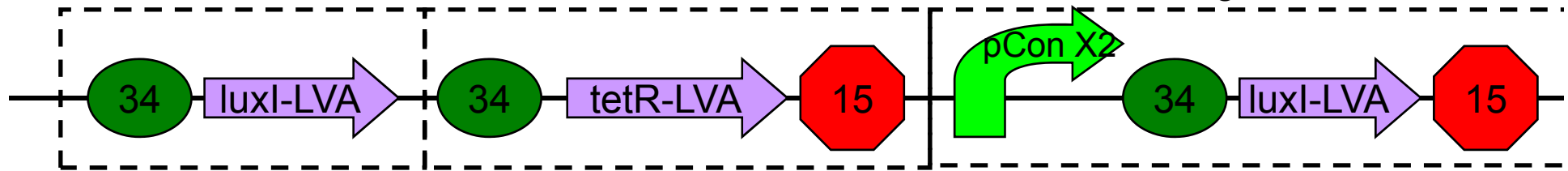

### Automatic Controller

### Quorum Sensing

### Quorum Sensing

### Selection Function

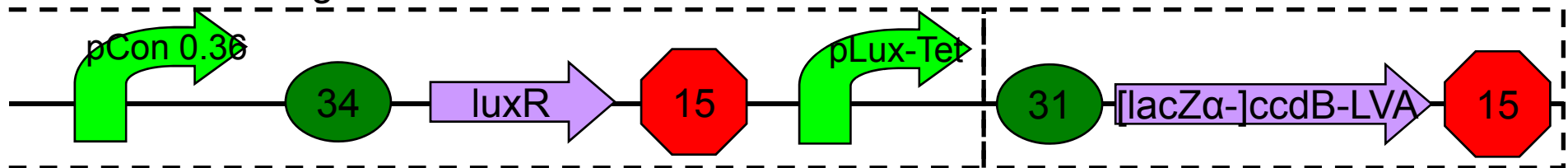

- 21. cl + pCl
- 22. cl + pCl + GFP
- 23. (VR + pCon) × 7 + cl + pCl + GFP
- 24. cl + pCl + luxI
- 25. AID
- 26. [AID +] mRFP + cl + pCl + luxI
- 27. [AID +] mRFP + cl + pCl + luxI + tetR + pCon + luxI + pCon + luxR + pLux-Tet [+ ccdB]
- 28. (VR + pCon) × 7 + mRFP + cl + pCl + luxI + tetR + pCon + luxI + pCon + luxR + pLux-Tet [+ ccdB]
- 29. pNOT
- 30. pNOT + GFP
- 31. pNOT + [AID +] mRFP + cl + pCl + luxI
- 32. pNOT + [AID +] mRFP + cl + pCl + luxI + tetR + pCon + luxI + pCon + luxR + pLux-Tet [+ ccdB]
- 33. repressor
- 34. pNOT + repressor

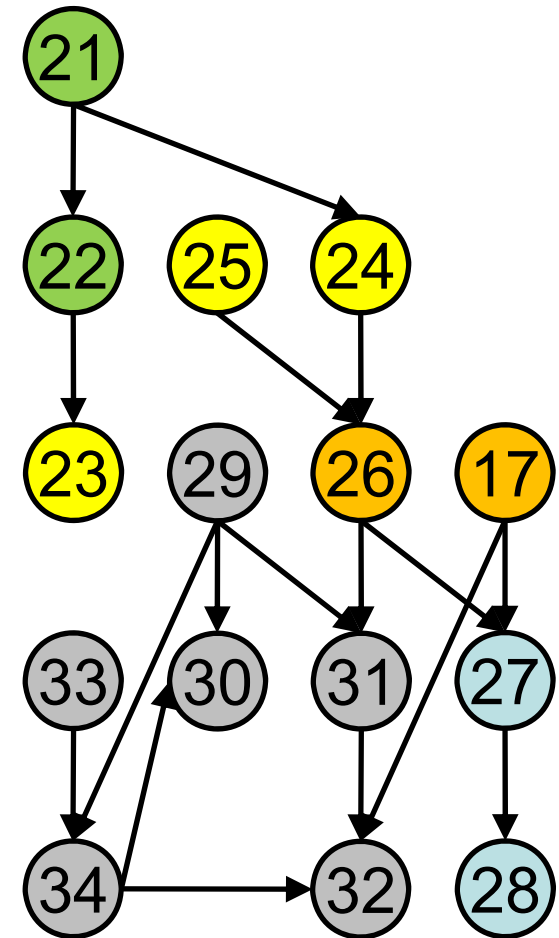

1

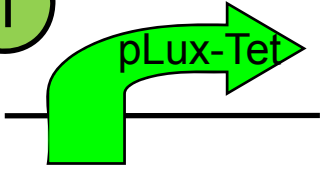

K176000 X+P with nicks  
Sequence OK



G00100  
Synthesis OK



G00101  
Synthesis OK

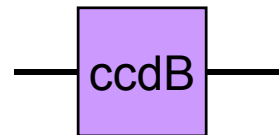

P1010 in pSB1A3 in DB 3.1  
Length OK



pSB1A3 X+P  
Length OK

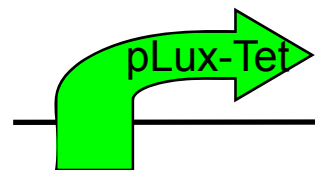

K176000 in pSB1A3  
Sequence OK



2

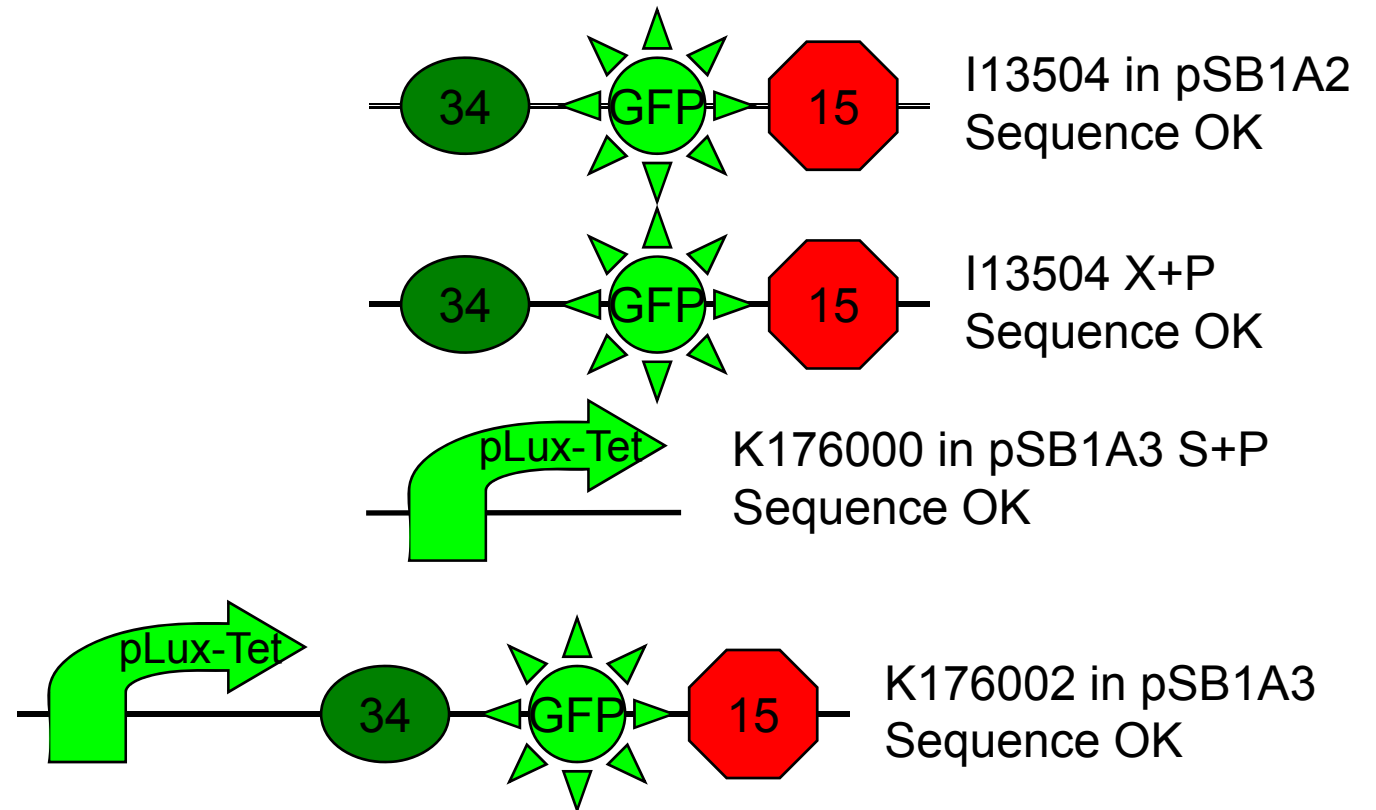

4



K145151 in pSB1A2 in DB3.1

Sequence OK

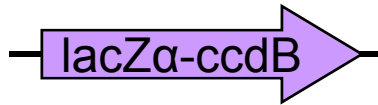

K176003 fragment  
Length OK



B0034 in pSB1A2  
Sequence OK



B0034 in pSB1A2 S+P  
Length OK

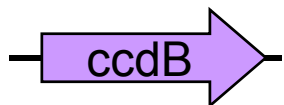

K145151 X+P  
Length OK

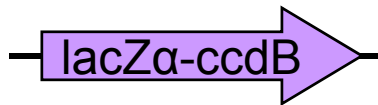

K176003 X+P  
Length OK

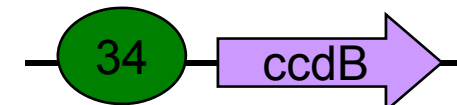

K176010 in pSB1A2 in DB3.1  
Ligation

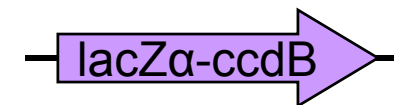

K176003 in pSB1A3 in DB3.1  
Sequence OK

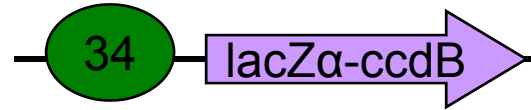

K176027 in pSB1A2 in DB3.1  
Sequence OK

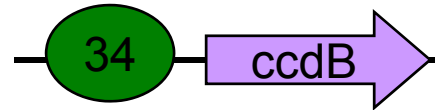

K176010 E+S  
Length OK

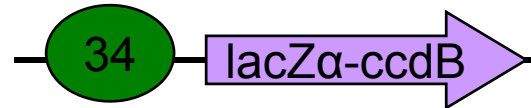

K176027 E+S  
Length OK

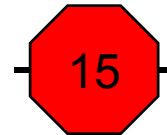

B0015 in pSB1AK3  
Sequence OK



B0031 in pSB1A2  
Length OK



B0031 S+P  
Length OK

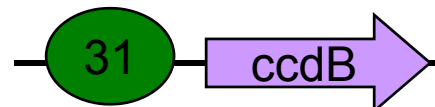

K176060 in pSB1A2 in DB3.1  
Sequence OK

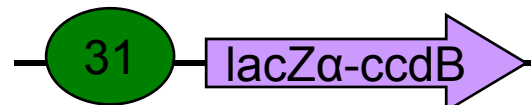

K176061 in pSB1A2 in DB3.1  
Sequence OK

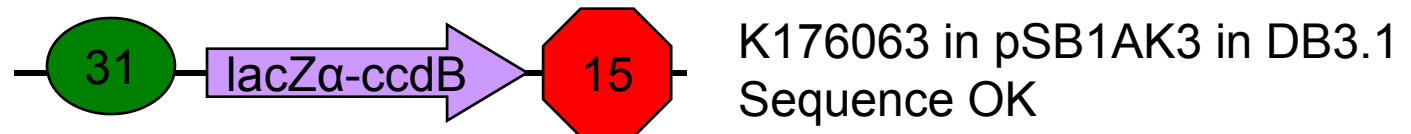
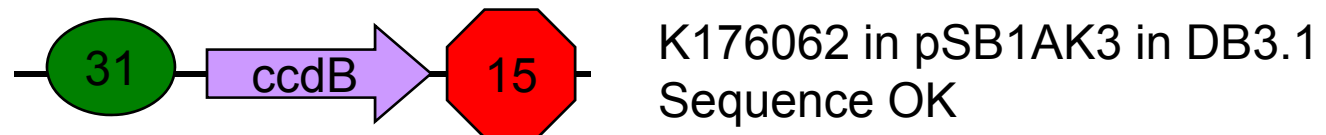
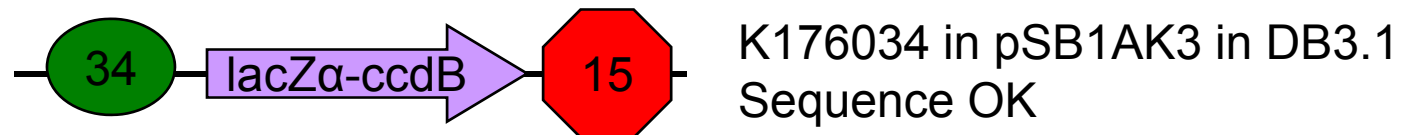
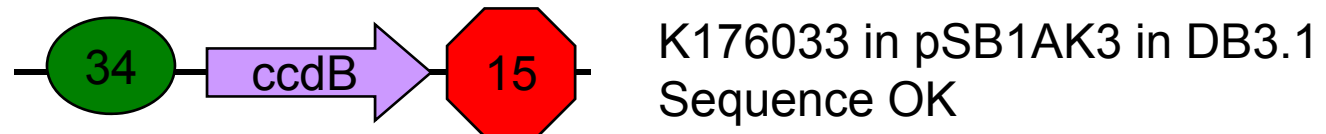
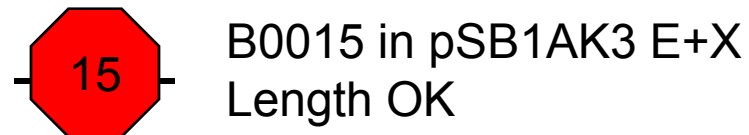
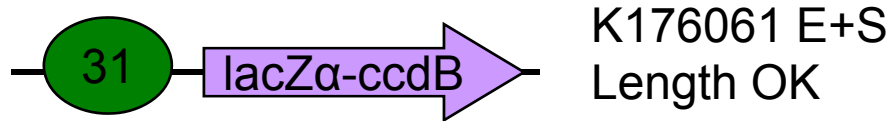
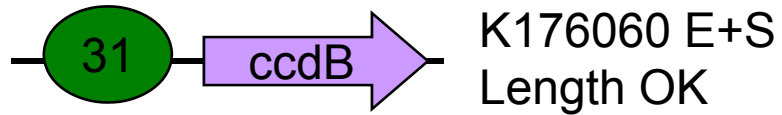

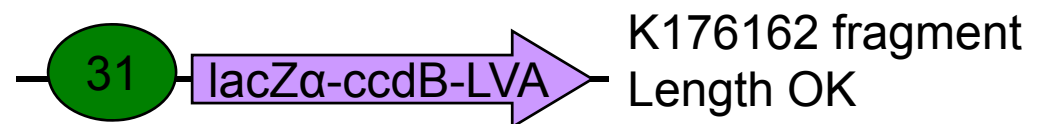
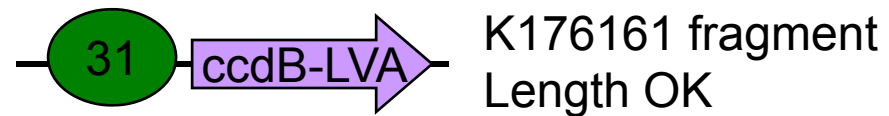
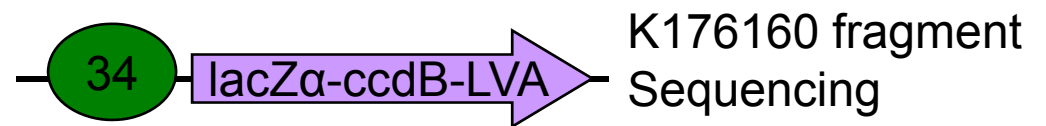
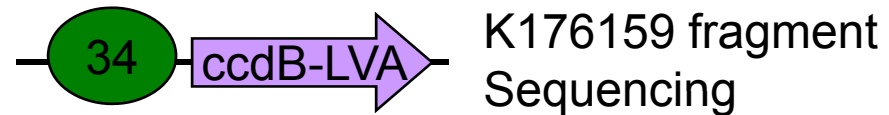
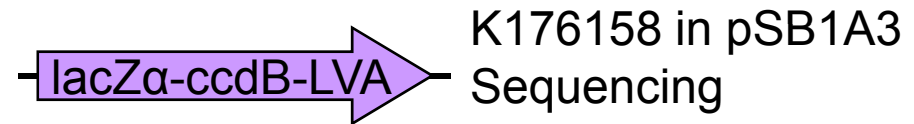
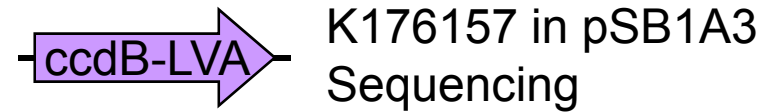
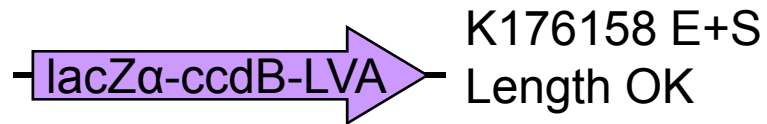
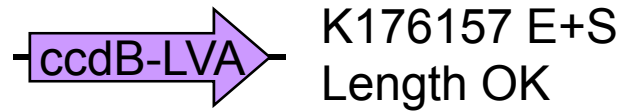
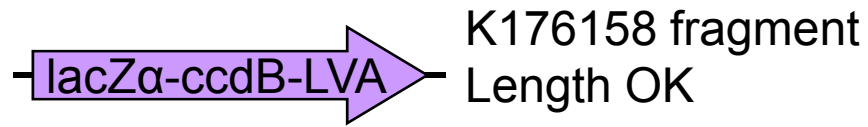

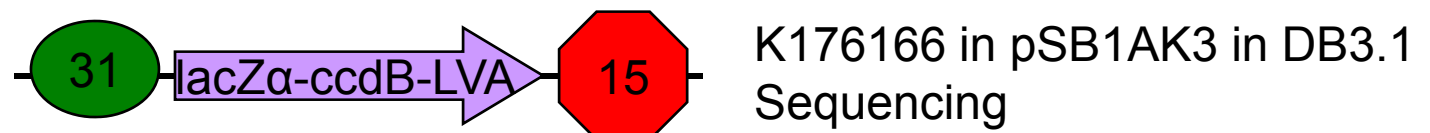
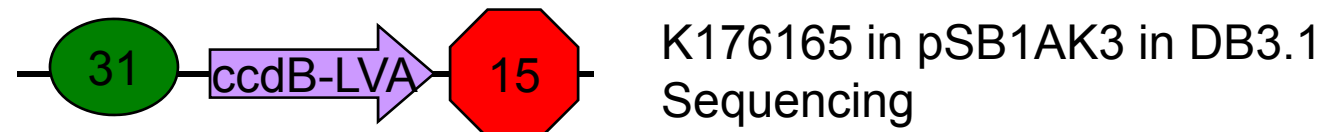
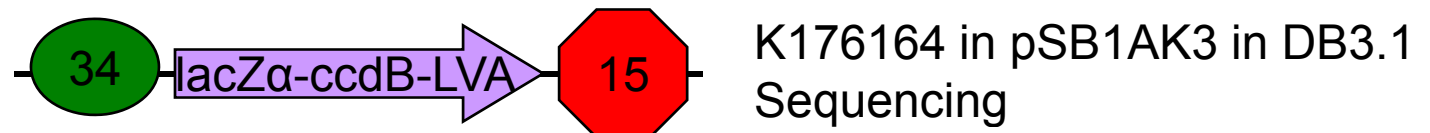
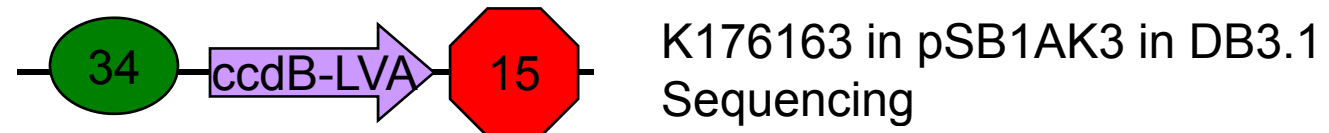
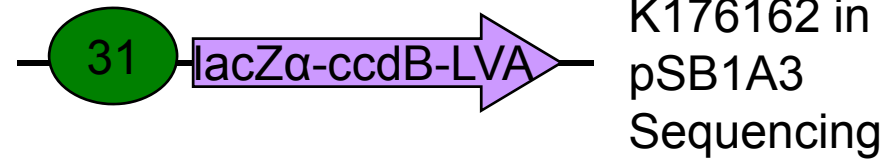
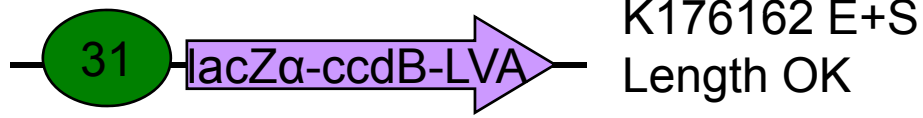
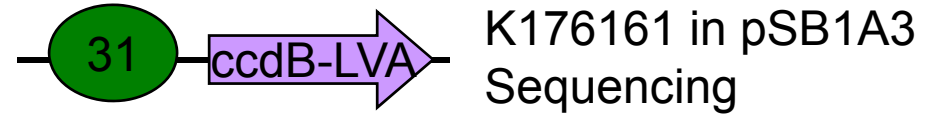
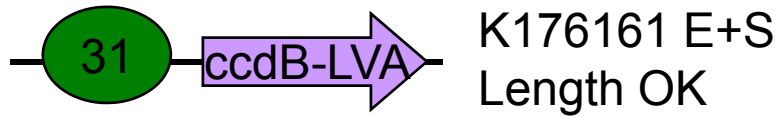
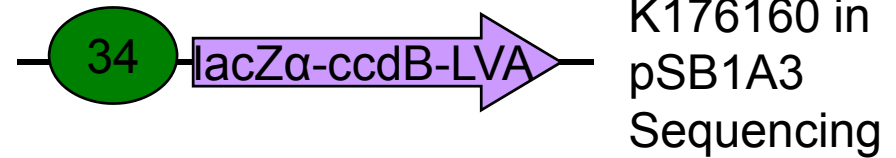
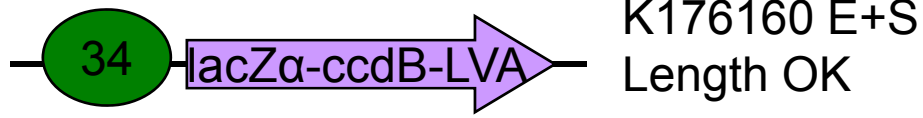
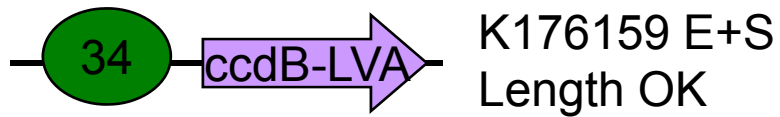

5

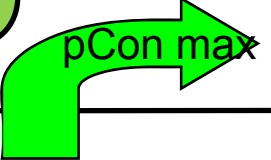
 pCon max  
J23119 in pSB1A2  
Sequence OK

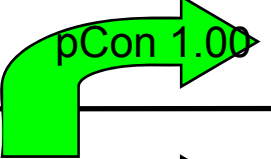
 pCon 1.00  
J23100 in J61002  
Sequence ?

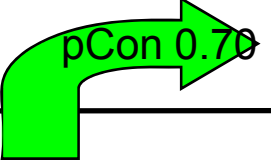
 pCon 0.70  
J23101 in J61002  
Sequence OK

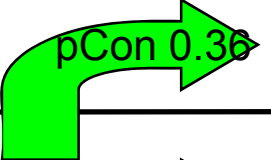
 pCon 0.36  
K176009 in J61002  
Sequence OK

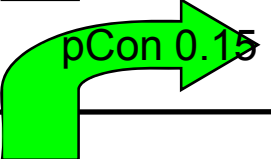
 pCon 0.15  
K176008 in J61002  
Sequence OK

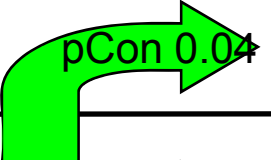
 pCon 0.04  
J23109 in J61002  
Sequence OK

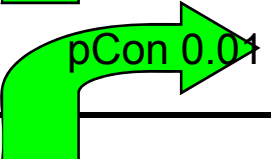
 pCon 0.04  
J23103 in J61002  
Sequence OK

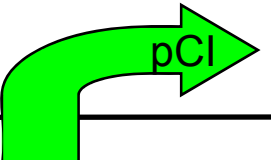
 pCl  
R0051 in pSB1A2  
Sequence OK

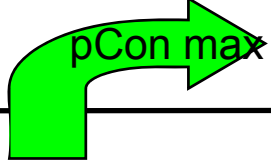
 pCon max  
J23119 X+P  
Sequence OK

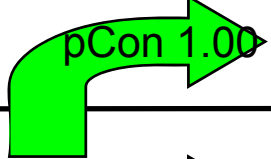
 pCon 1.00  
J23100-J61002SF X+P  
Sequence ?

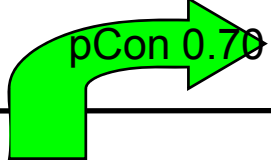
 pCon 0.70  
J23101-J61002SF X+P  
Sequence OK

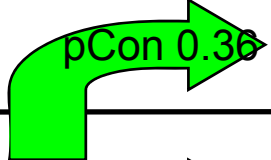
 pCon 0.36  
K176009-J61002SF X+P  
Sequence OK

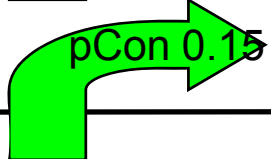
 pCon 0.15  
K176008-J61002SF X+P  
Sequence OK

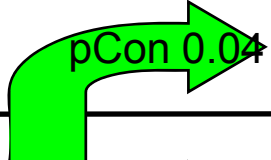
 pCon 0.04  
J23109-J61002SF X+P  
Sequence OK

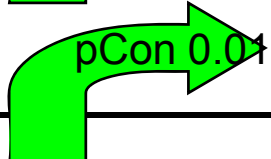
 pCon 0.04  
J23103-J61002SF X+P  
Sequence OK

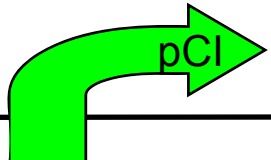
 pCl  
R0051 X+P  
Length OK

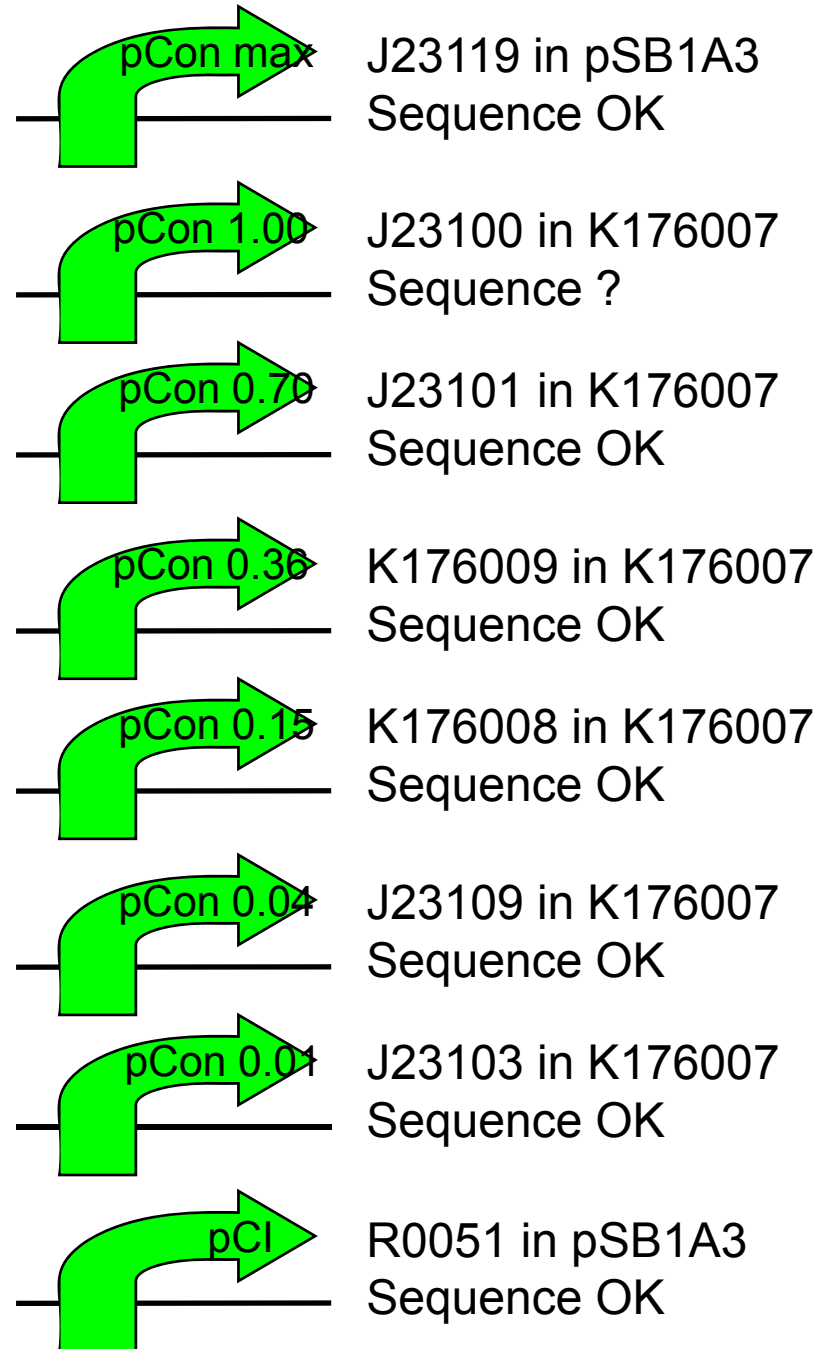

6

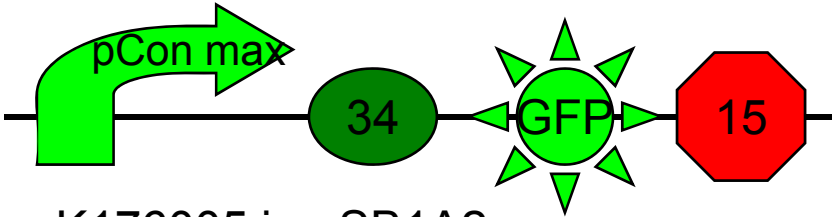
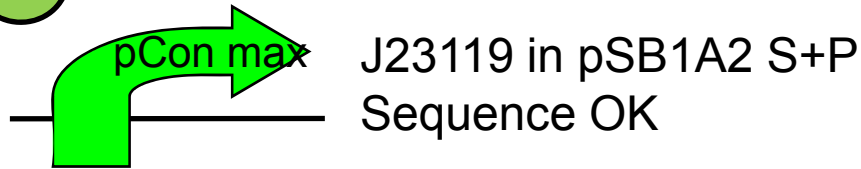

K176005 in pSB1A2  
Sequence OK

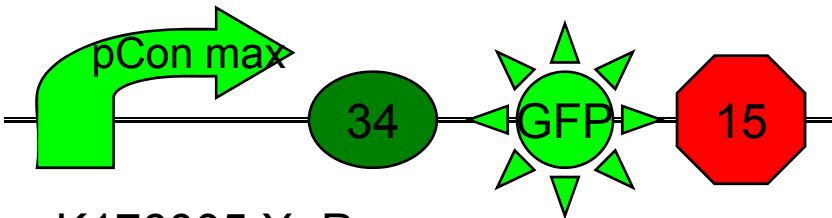

K176005 X+P  
Length OK

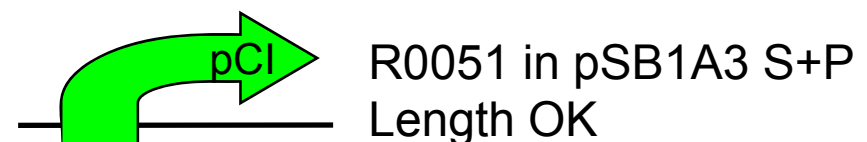
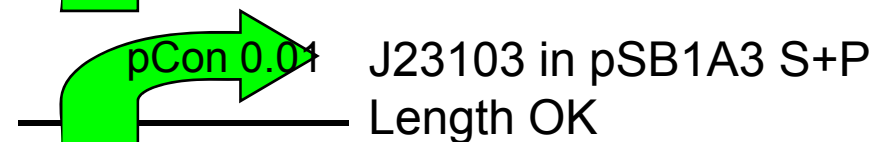
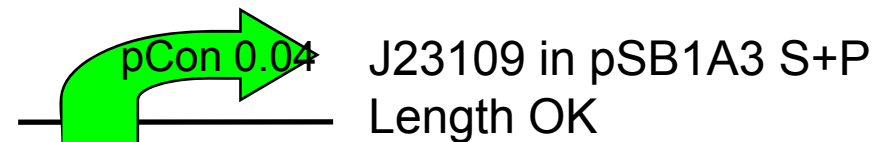
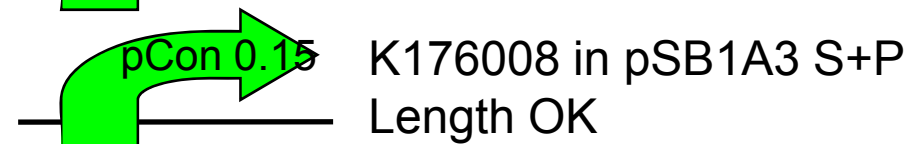
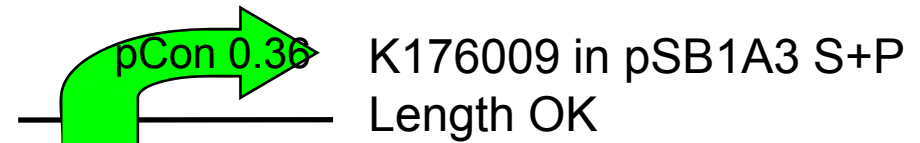
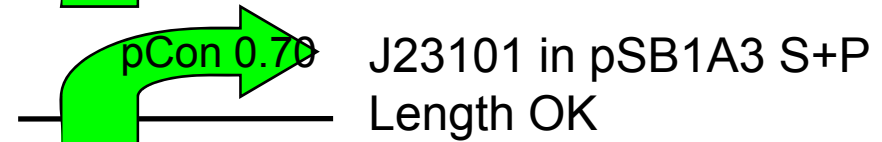
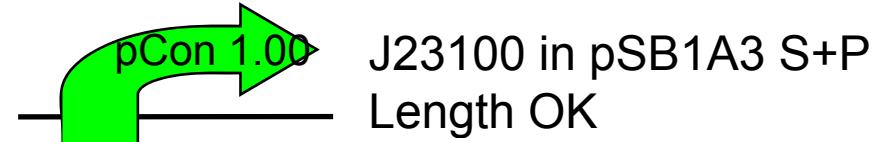
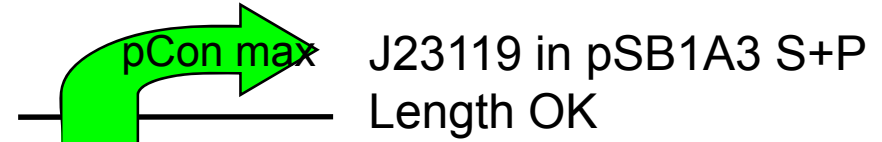



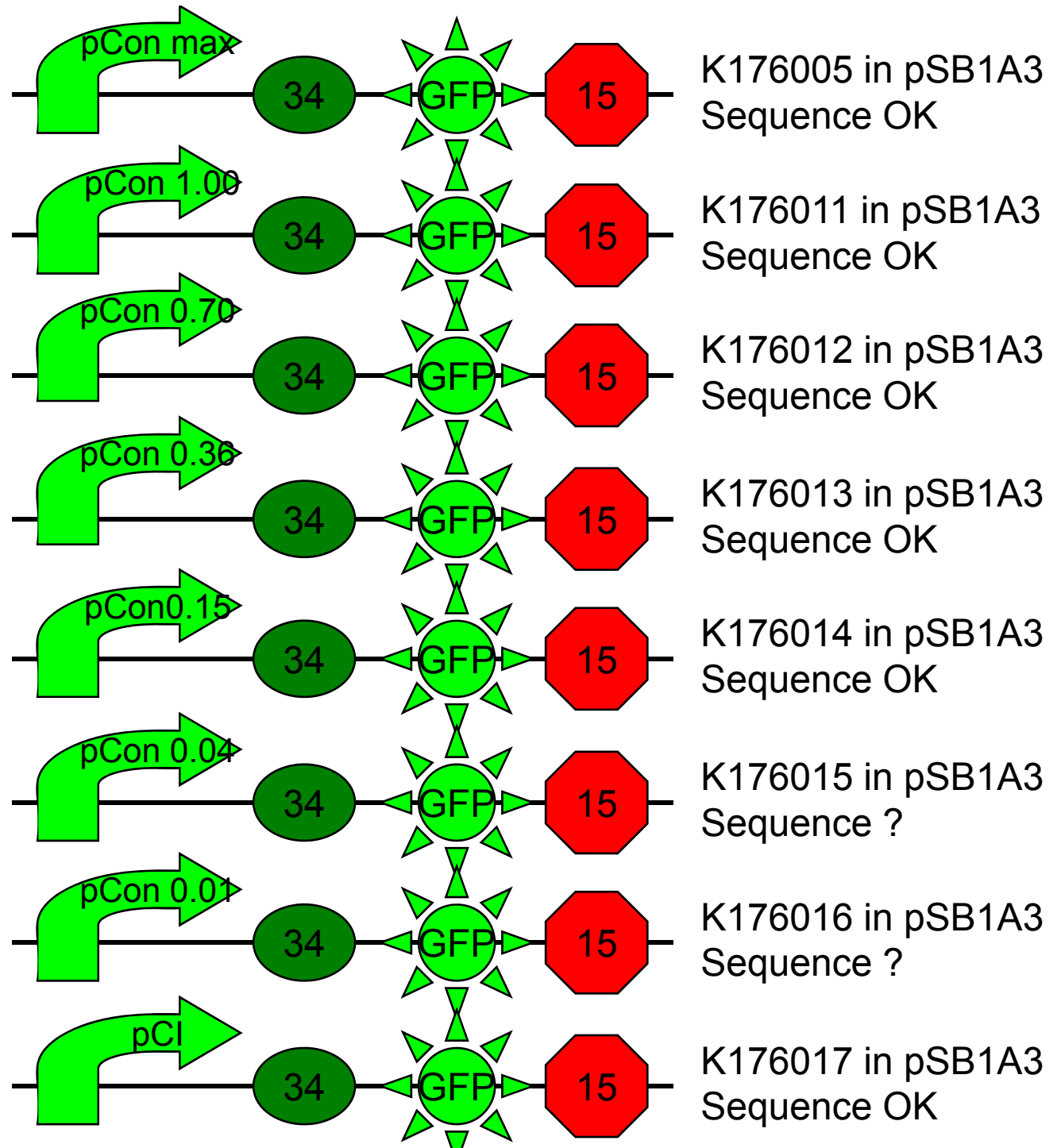

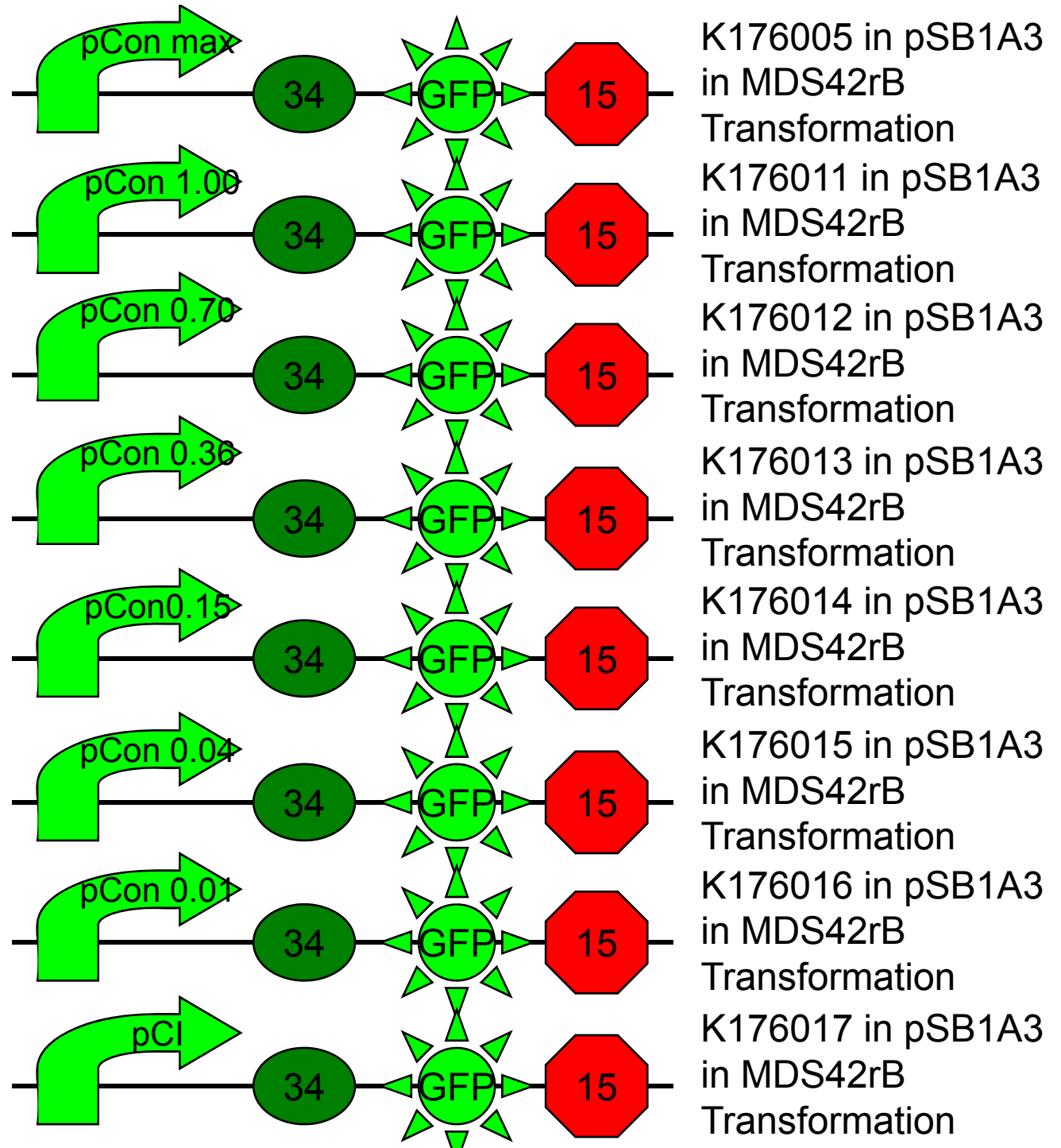







# MDS42 recA Blue

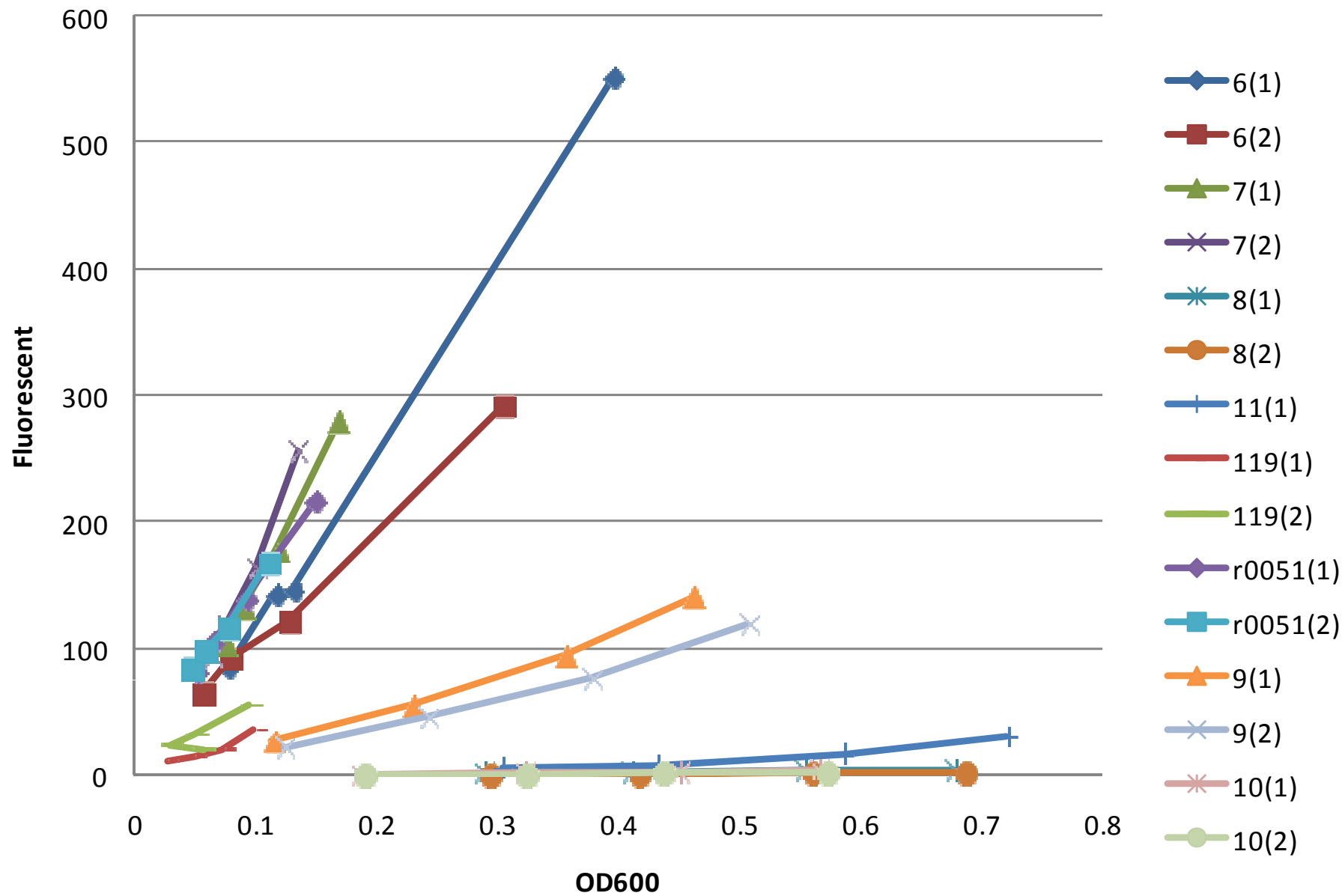

7

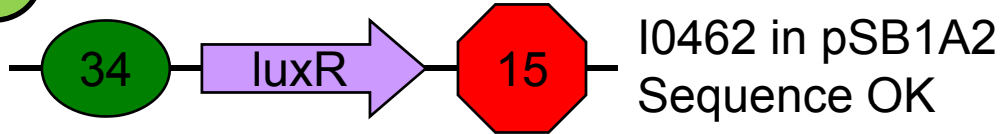

I0462 in pSB1A2  
Sequence OK

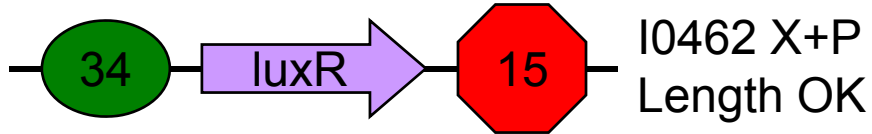

I0462 X+P  
Length OK

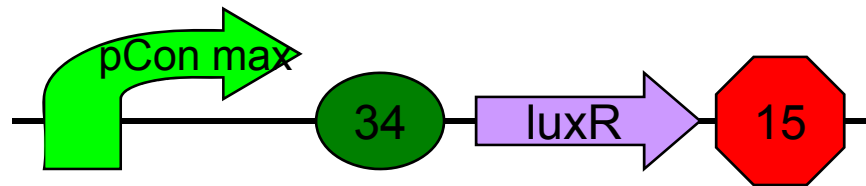

K176004 in pSB1A2  
Sequence OK  
Length ?

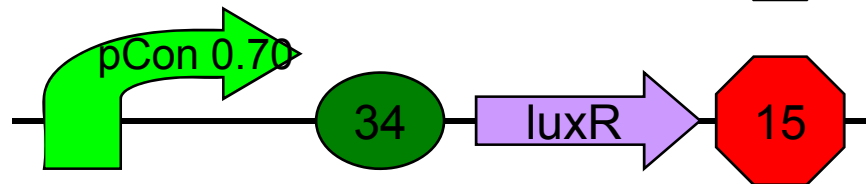

K176025 in pSB1A3  
Sequence ?

8

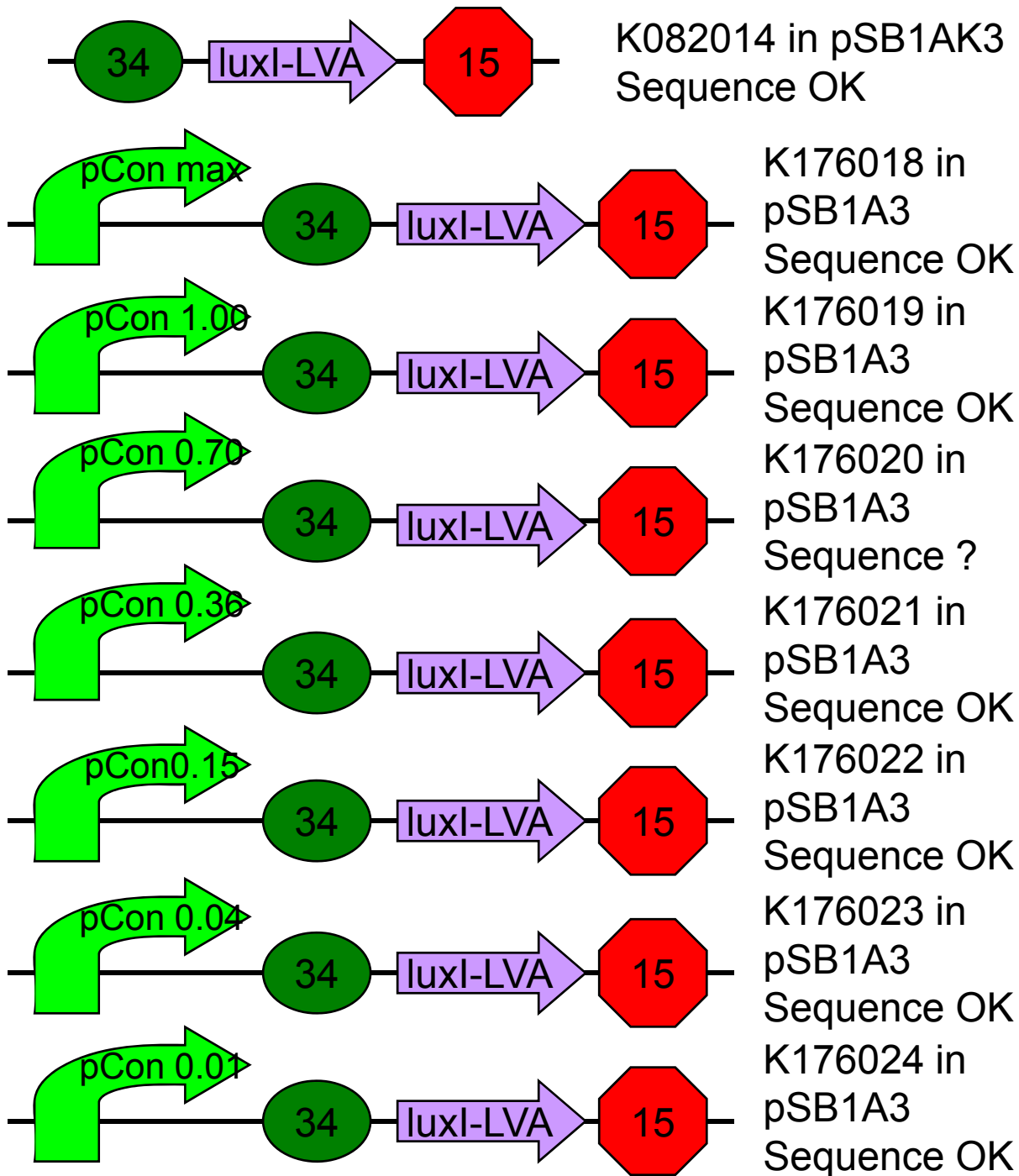



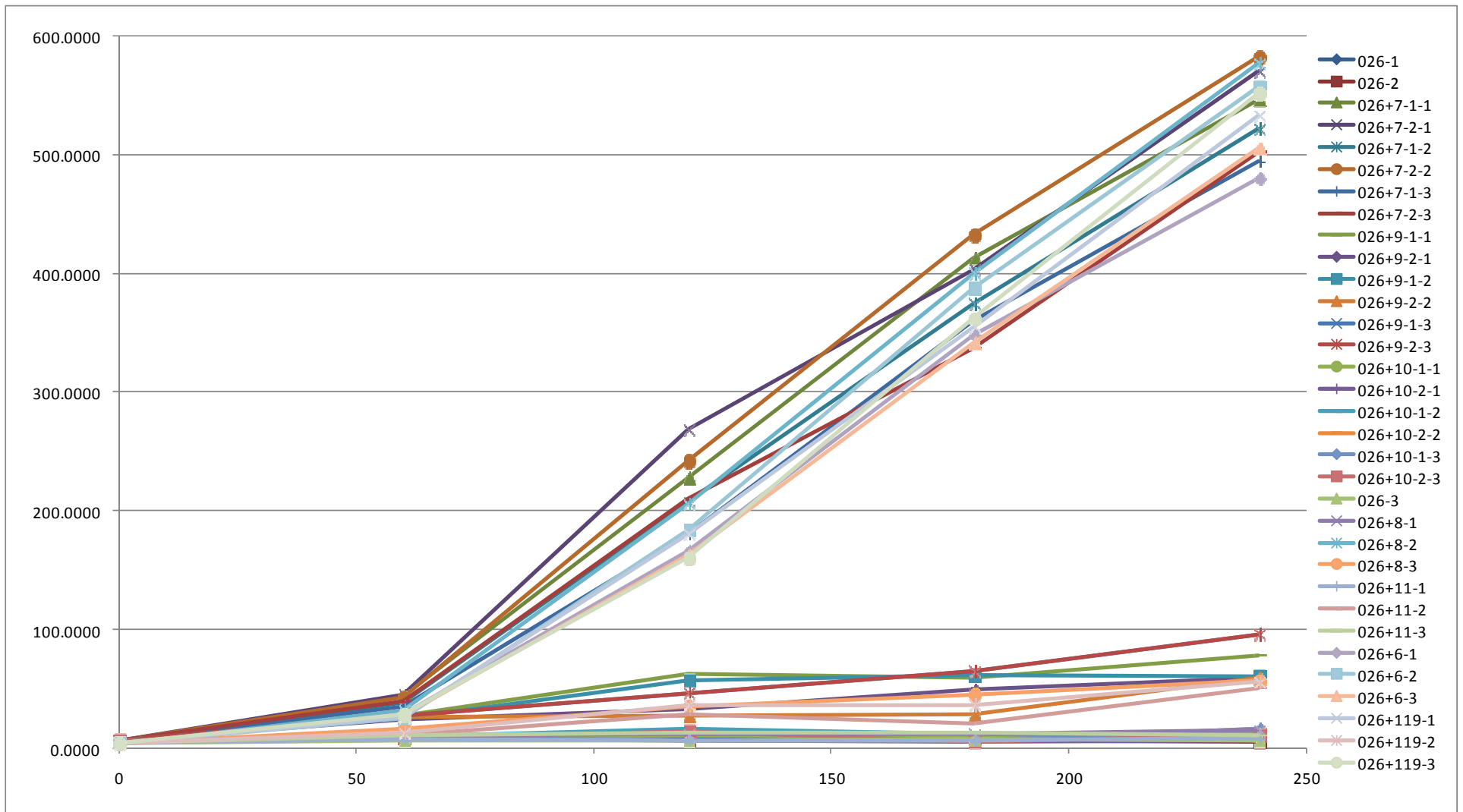

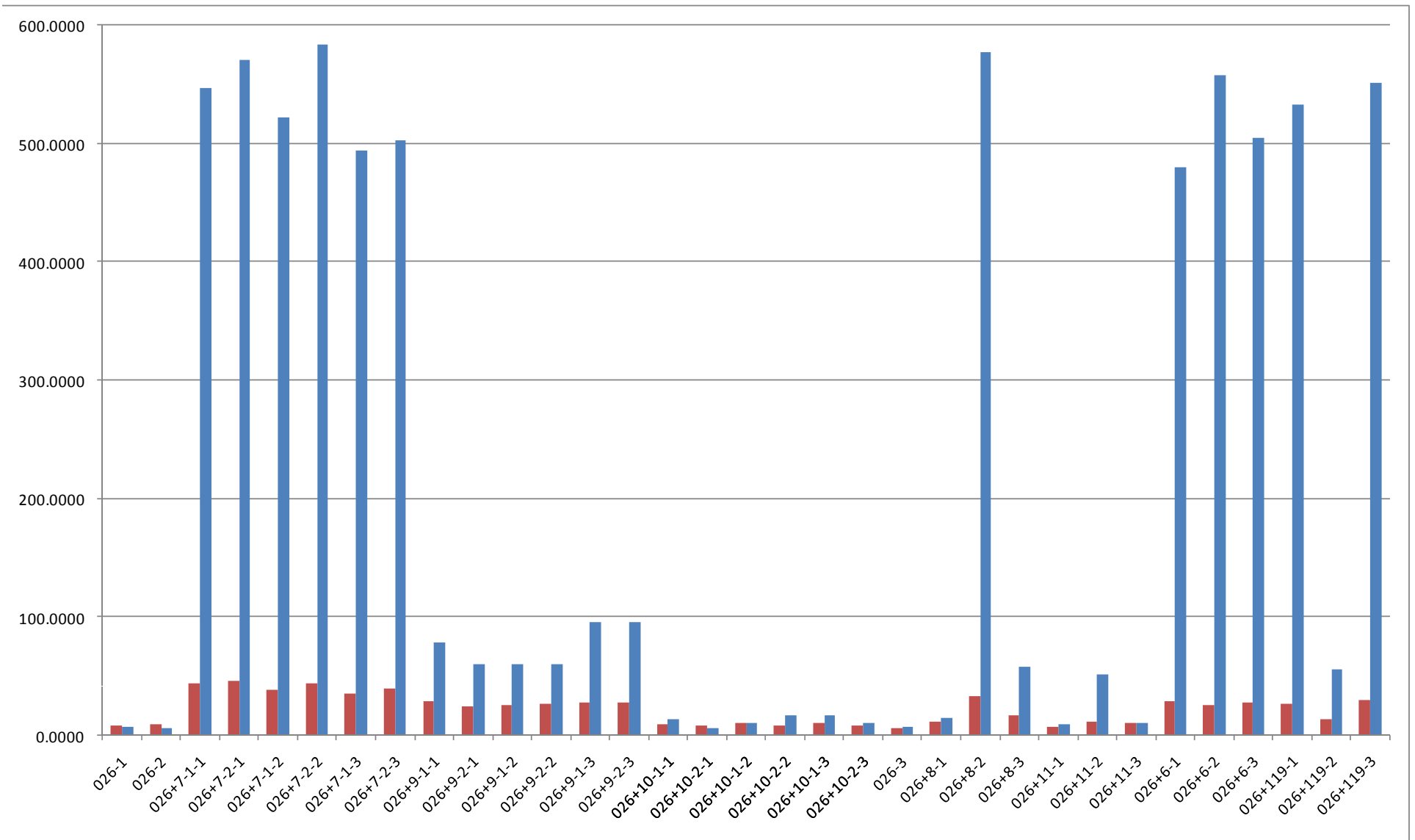

# 10+R+002 (K176003)

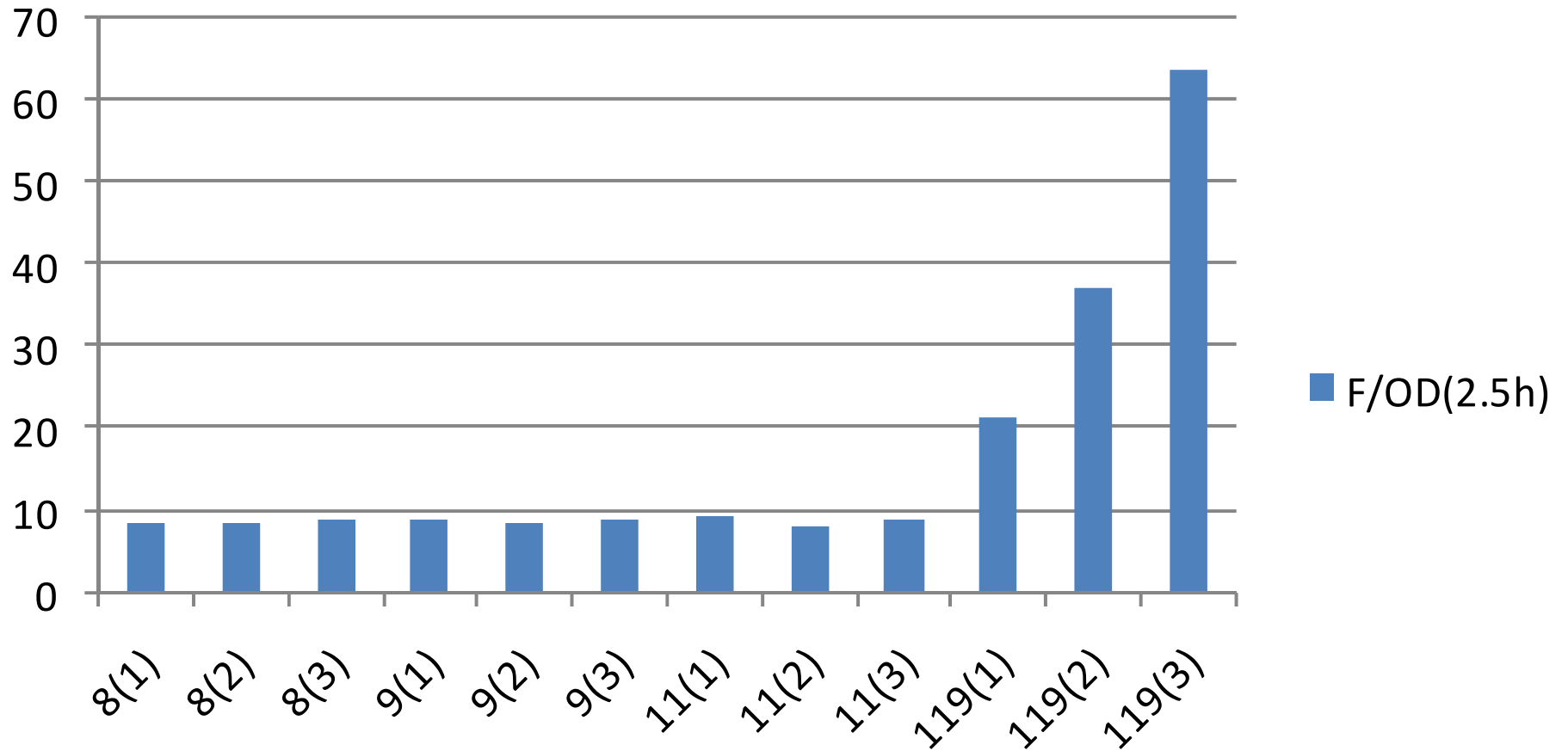

3

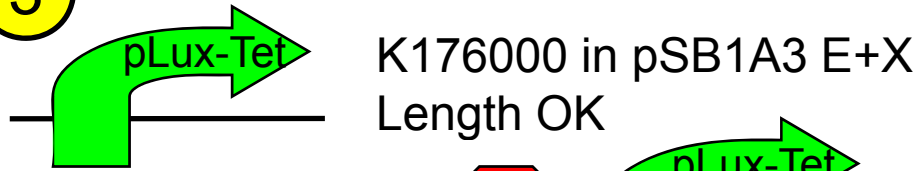

K176000 in pSB1A3 E+X  
Length OK

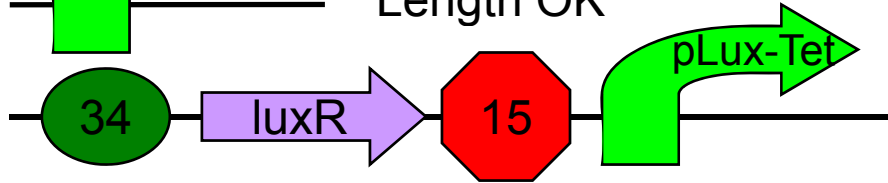

K176123 in pSB1A3  
Sequencing

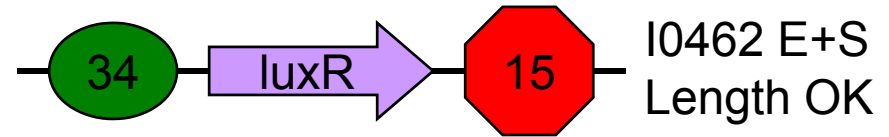

I0462 E+S  
Length OK

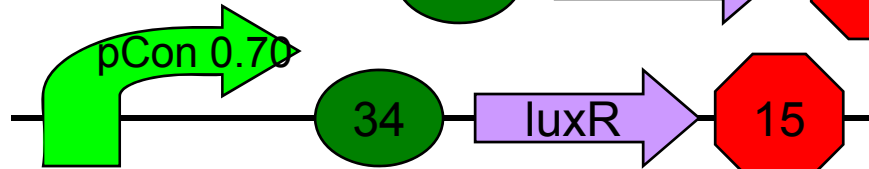

K176025 E+S  
Length OK

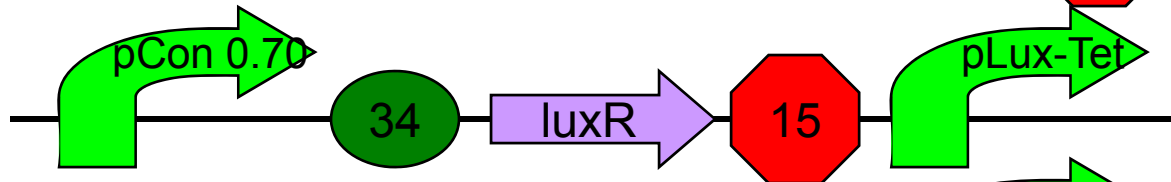

K176028 in pSB1A3  
Sequence ?

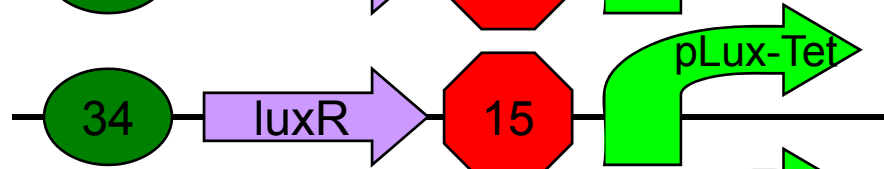

K176123 X+P  
Length OK

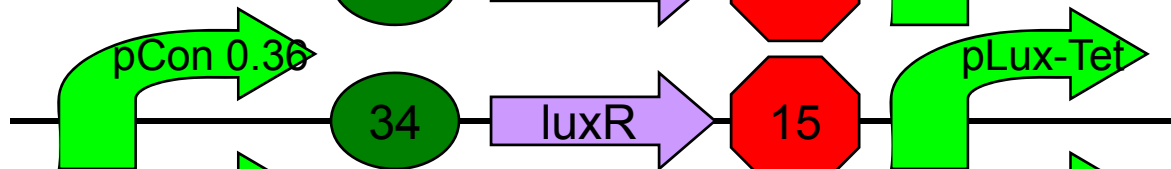

K176125 in pSB1A3  
Sequencing

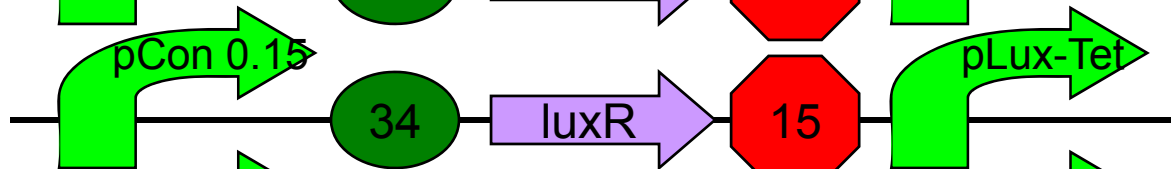

K176127 in pSB1A3  
Sequencing

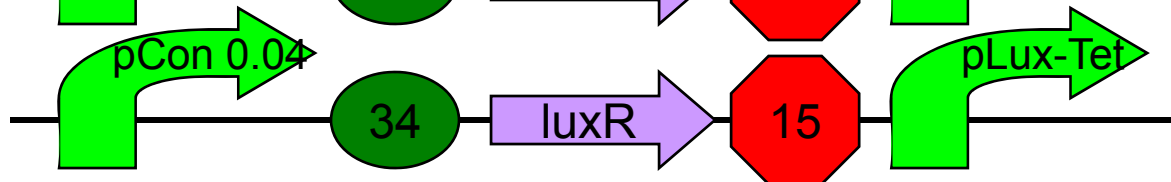

K176129 in pSB1A3  
Sequencing

9

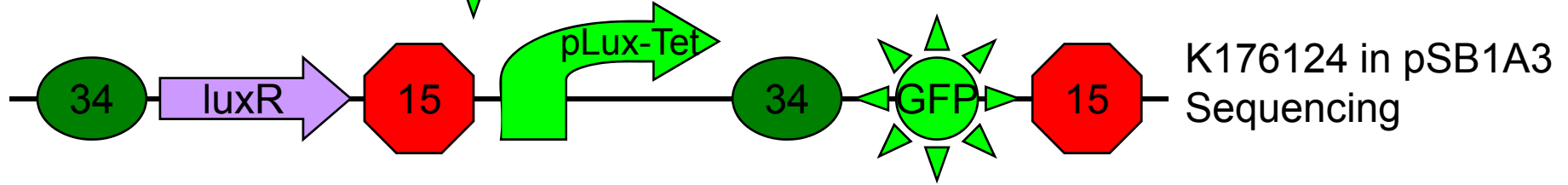
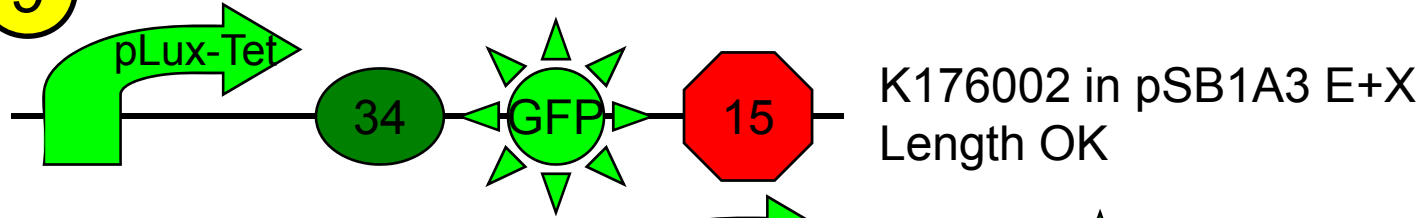

VRGFP ← G00201  
Synthesis OK

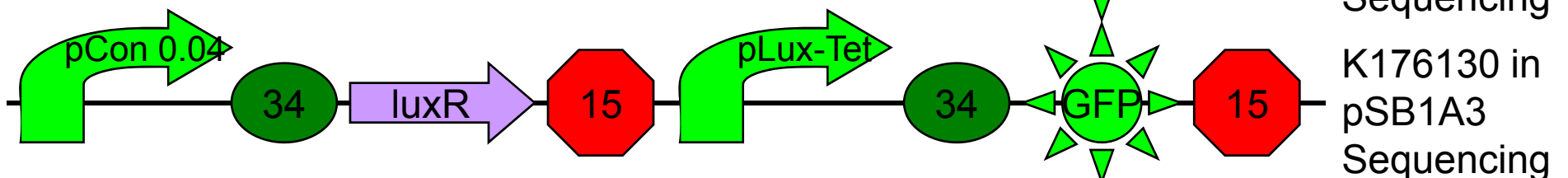
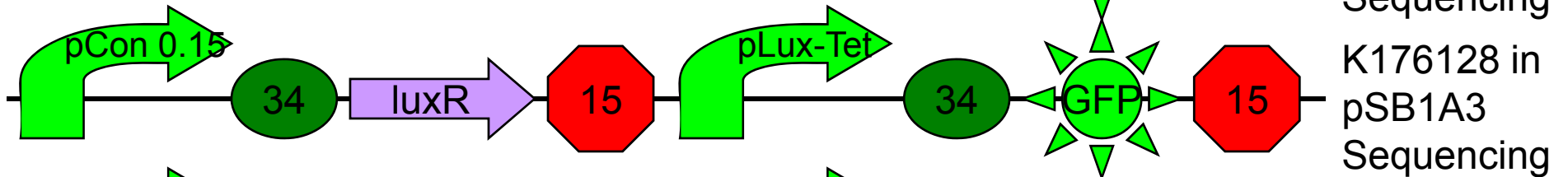
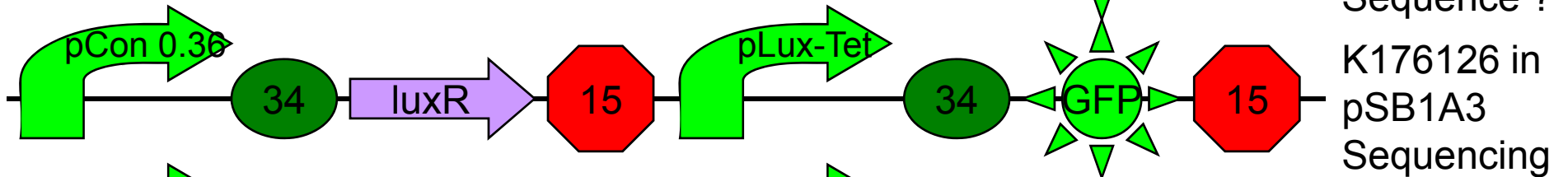
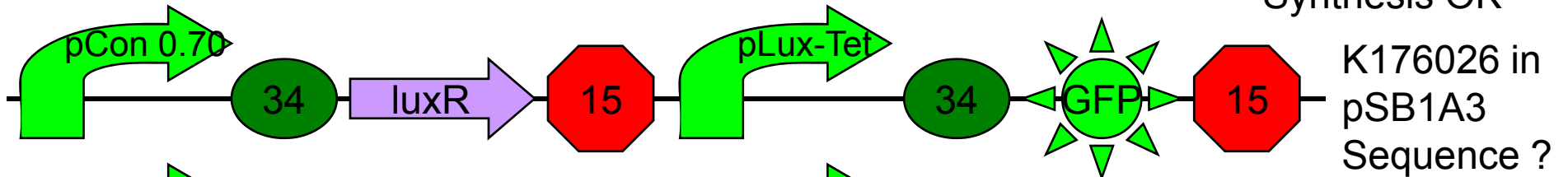

# Methods

- Plate Reader
- Spectrophotometer

Flu:t(min)

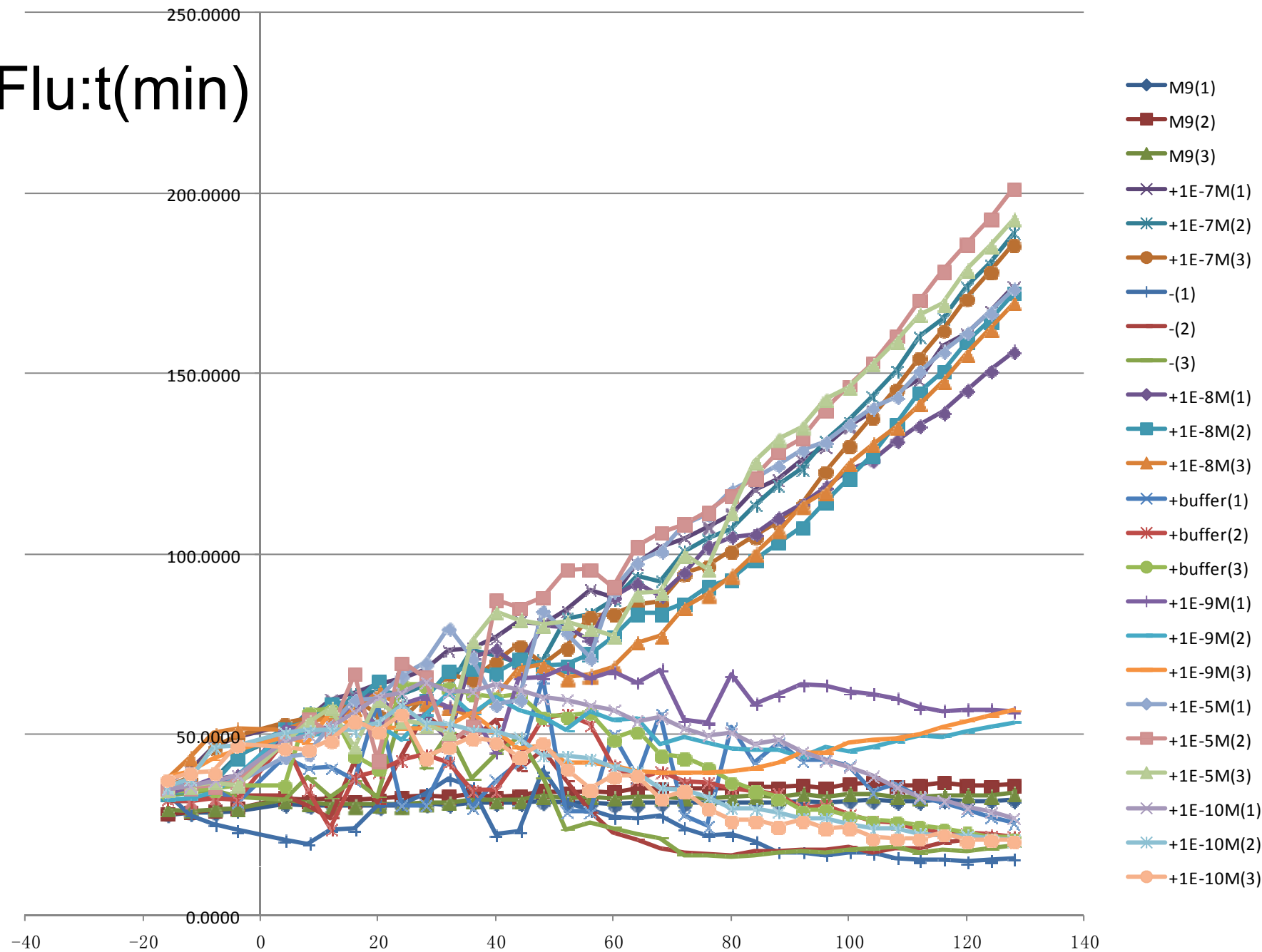

# Flu/OD:t(min)

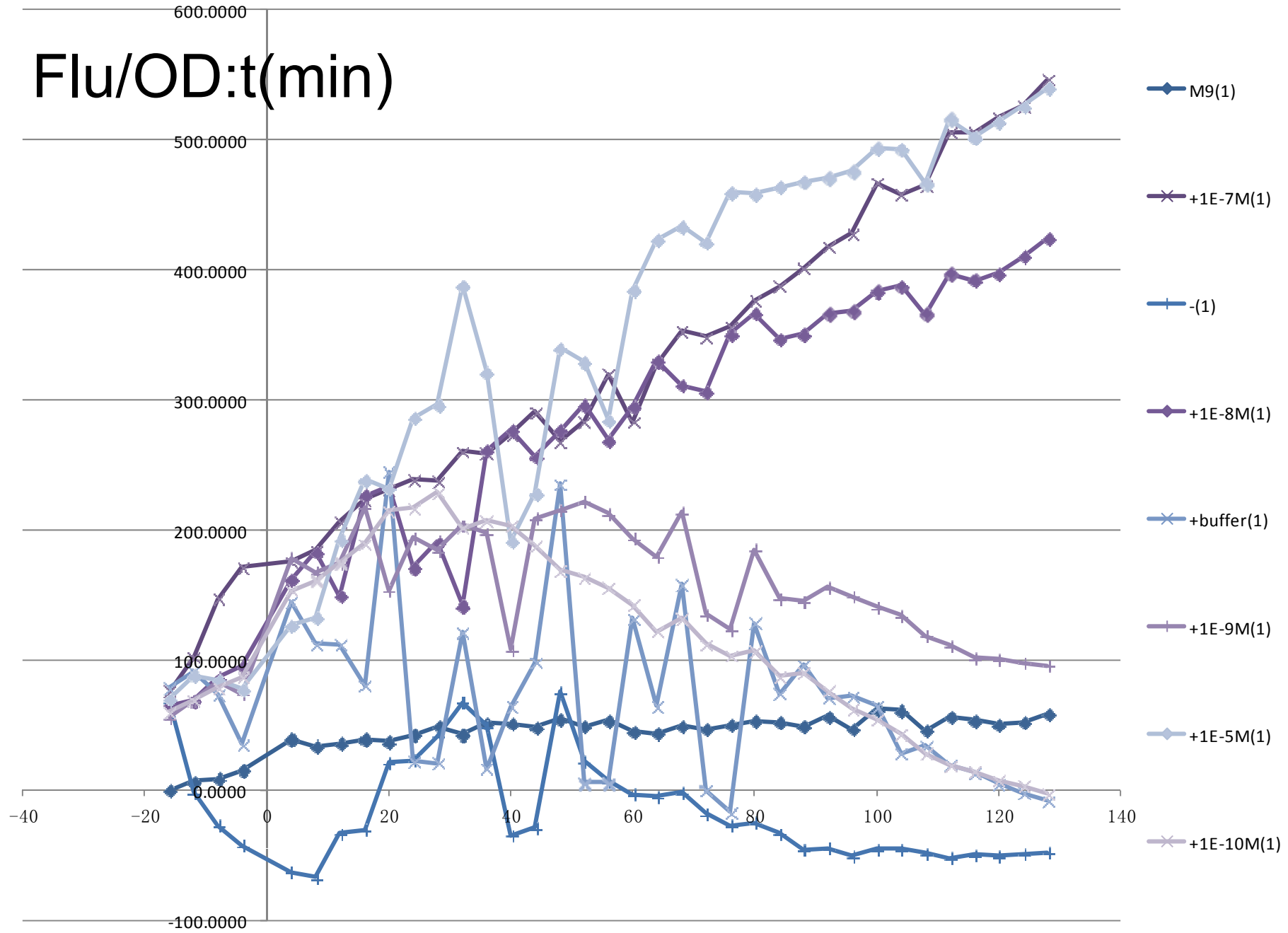



# Flu/OD:t(min)

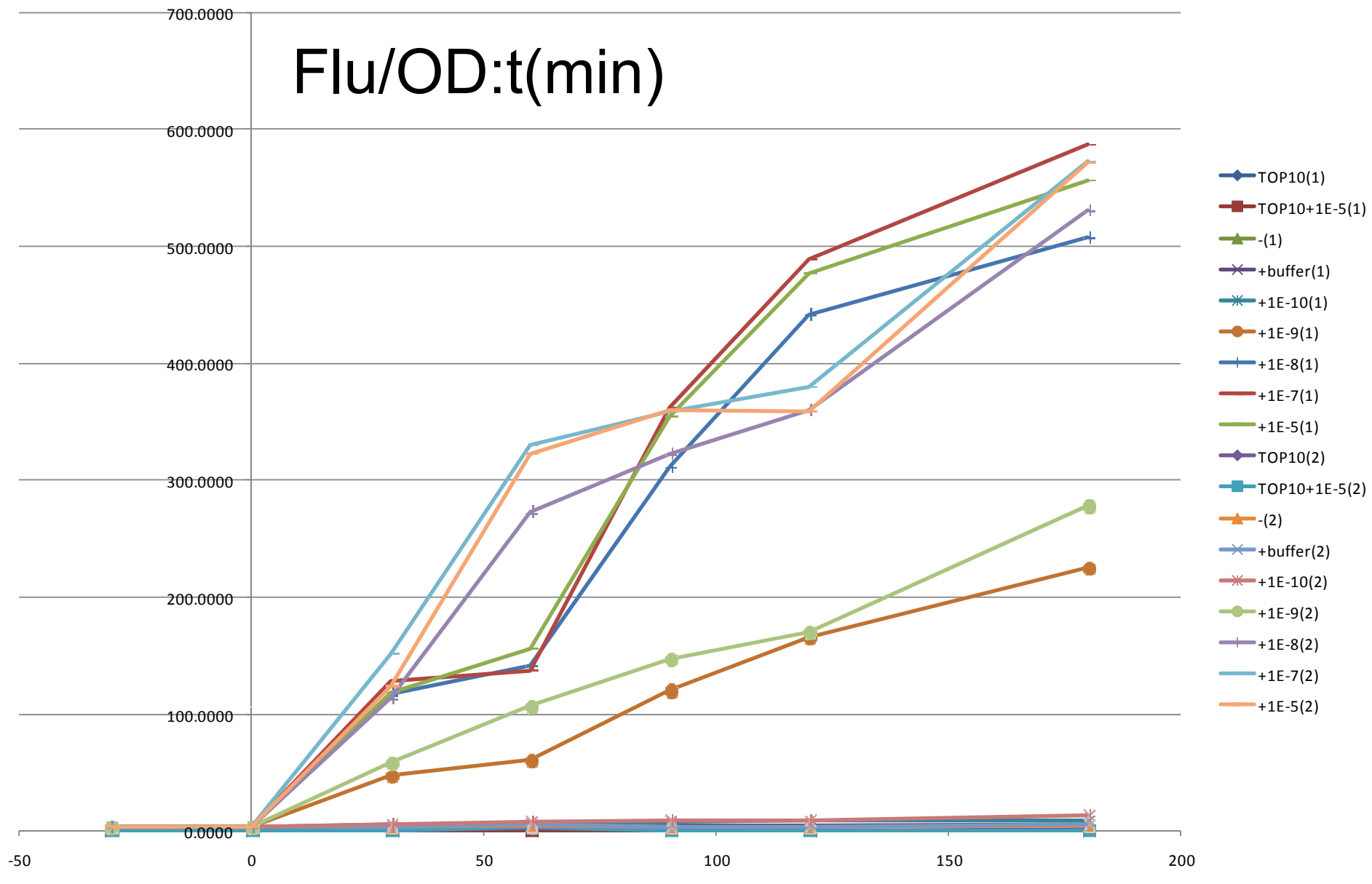

# Flu/OD:t(min)

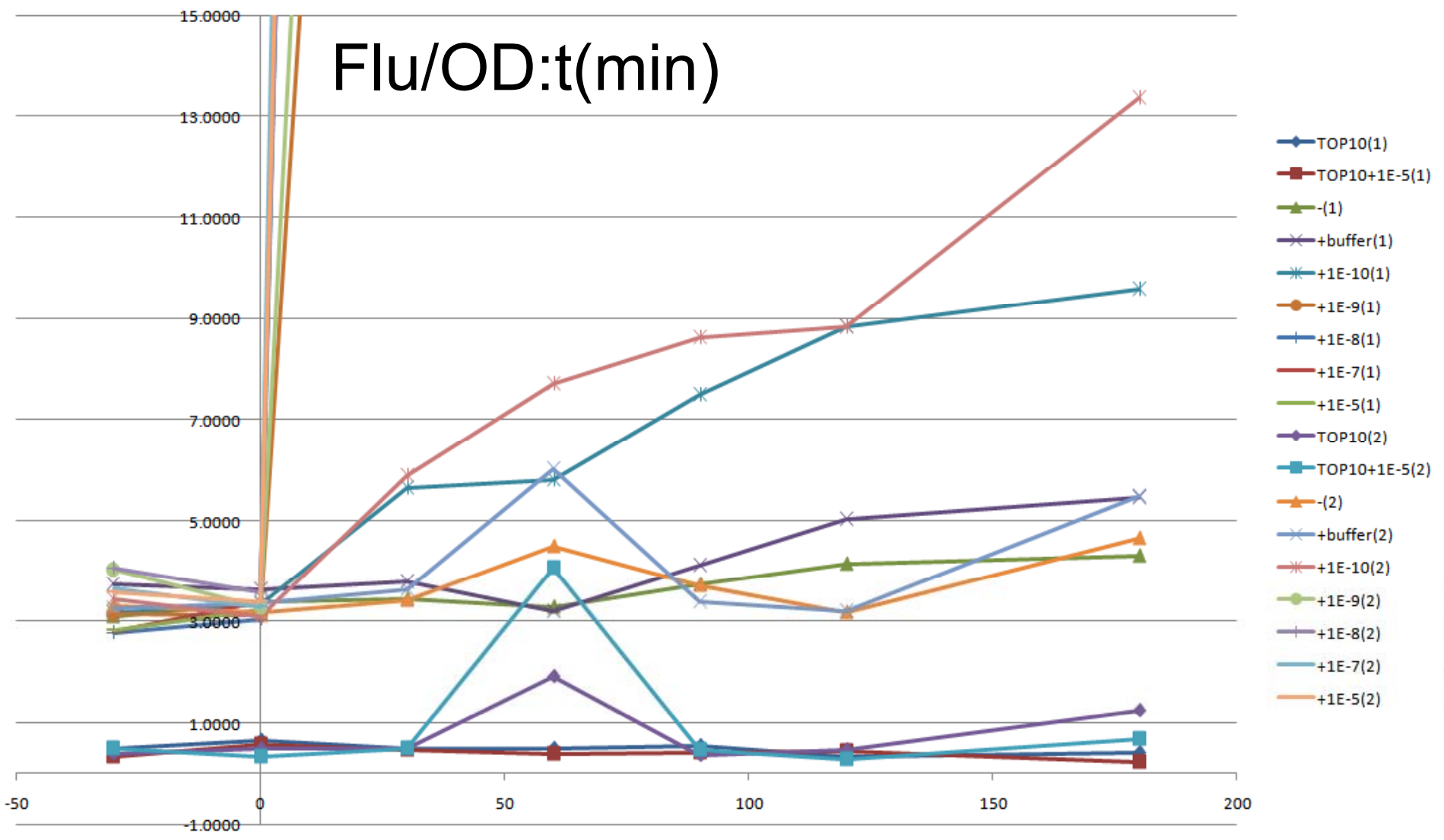

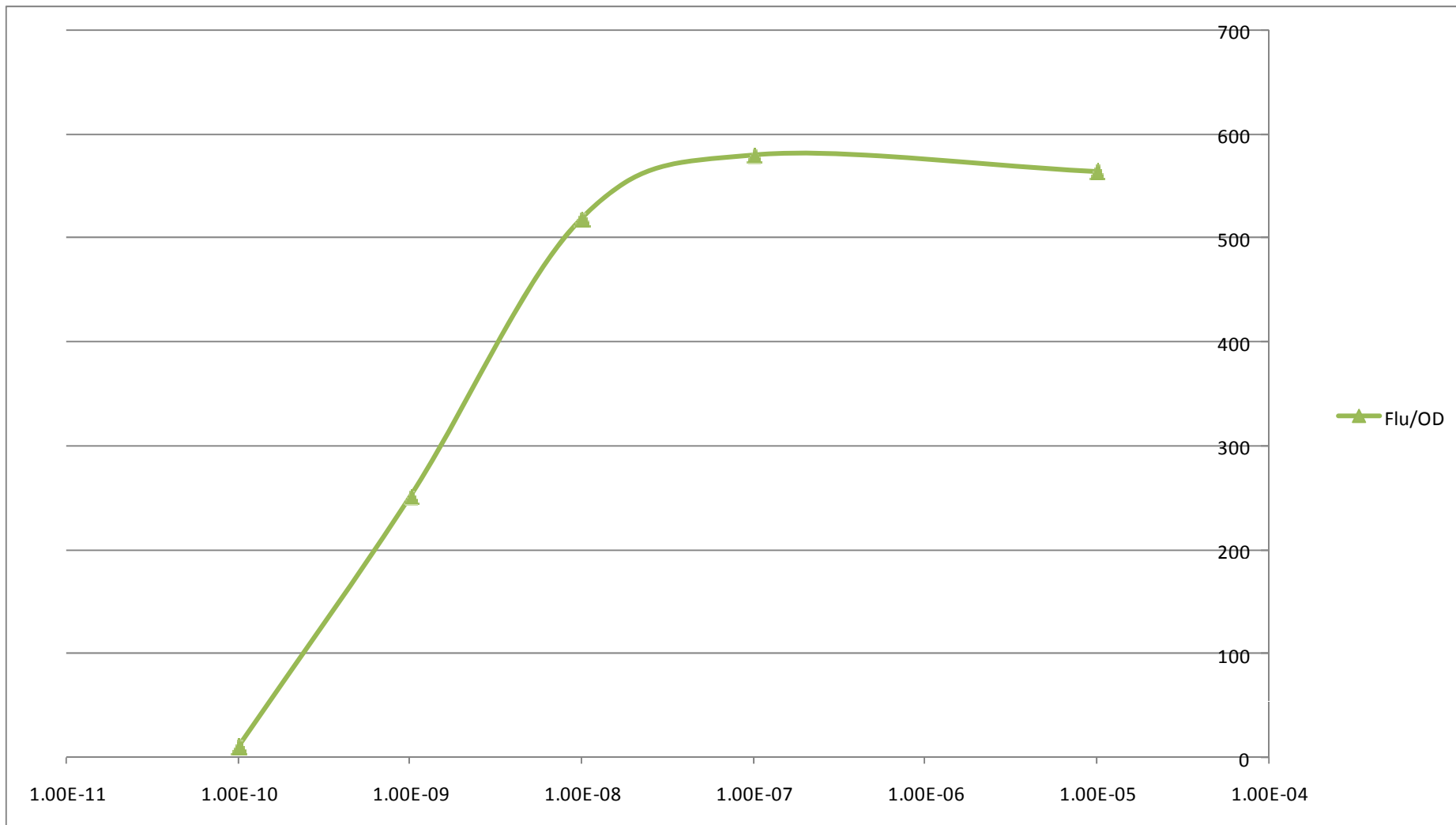

# F2620

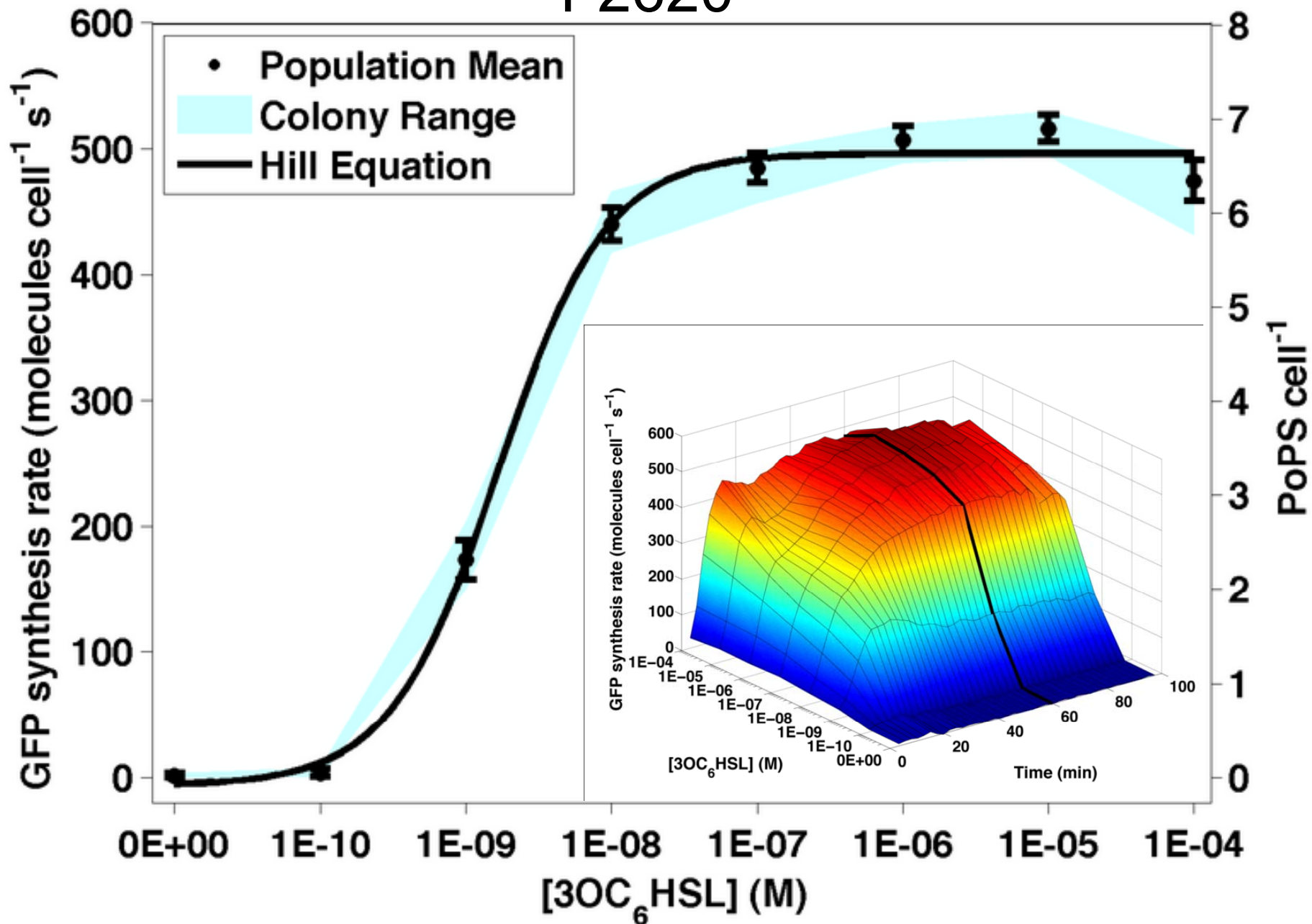



# 9+R+002 (K176126)

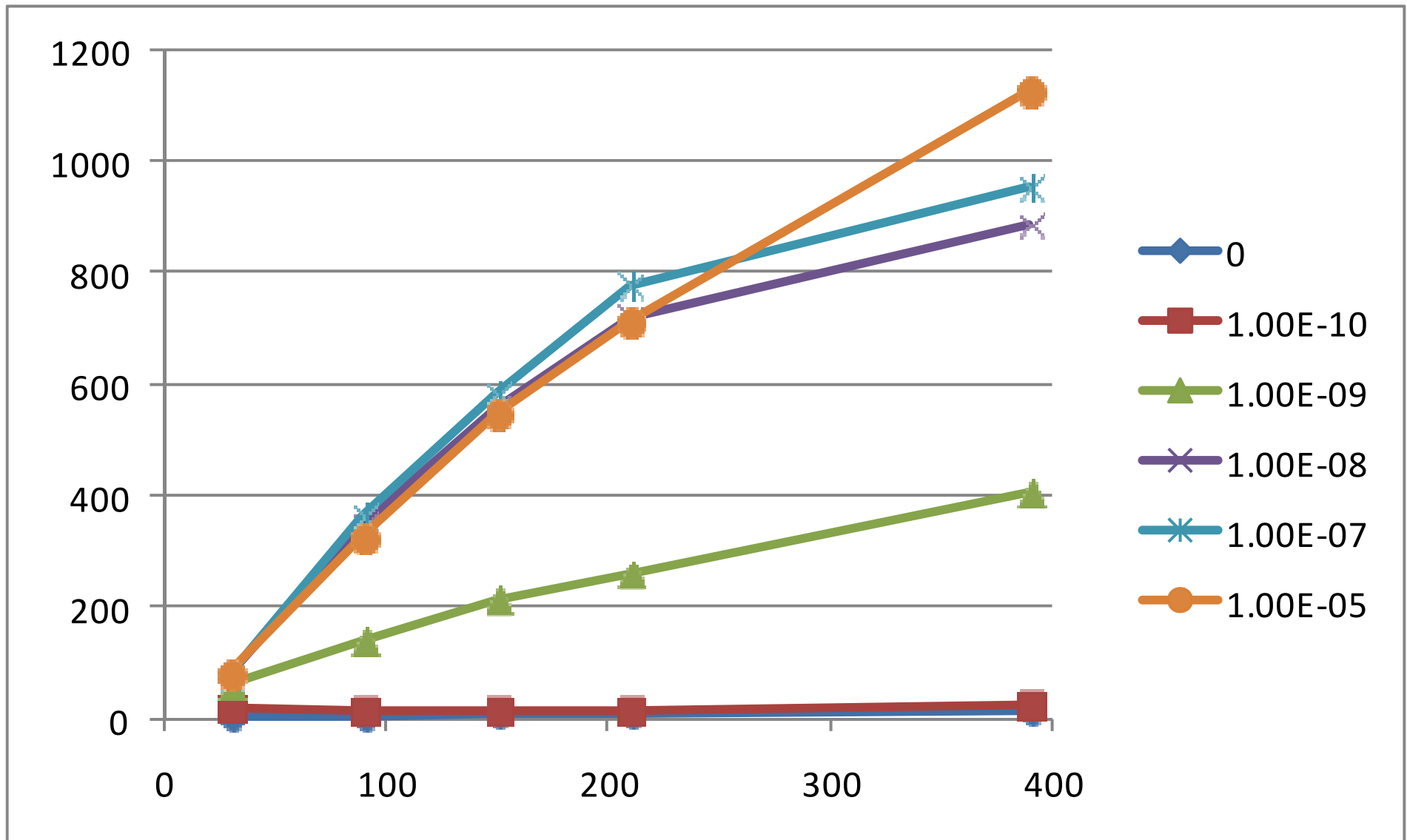

# 10+R+002 (K176130)

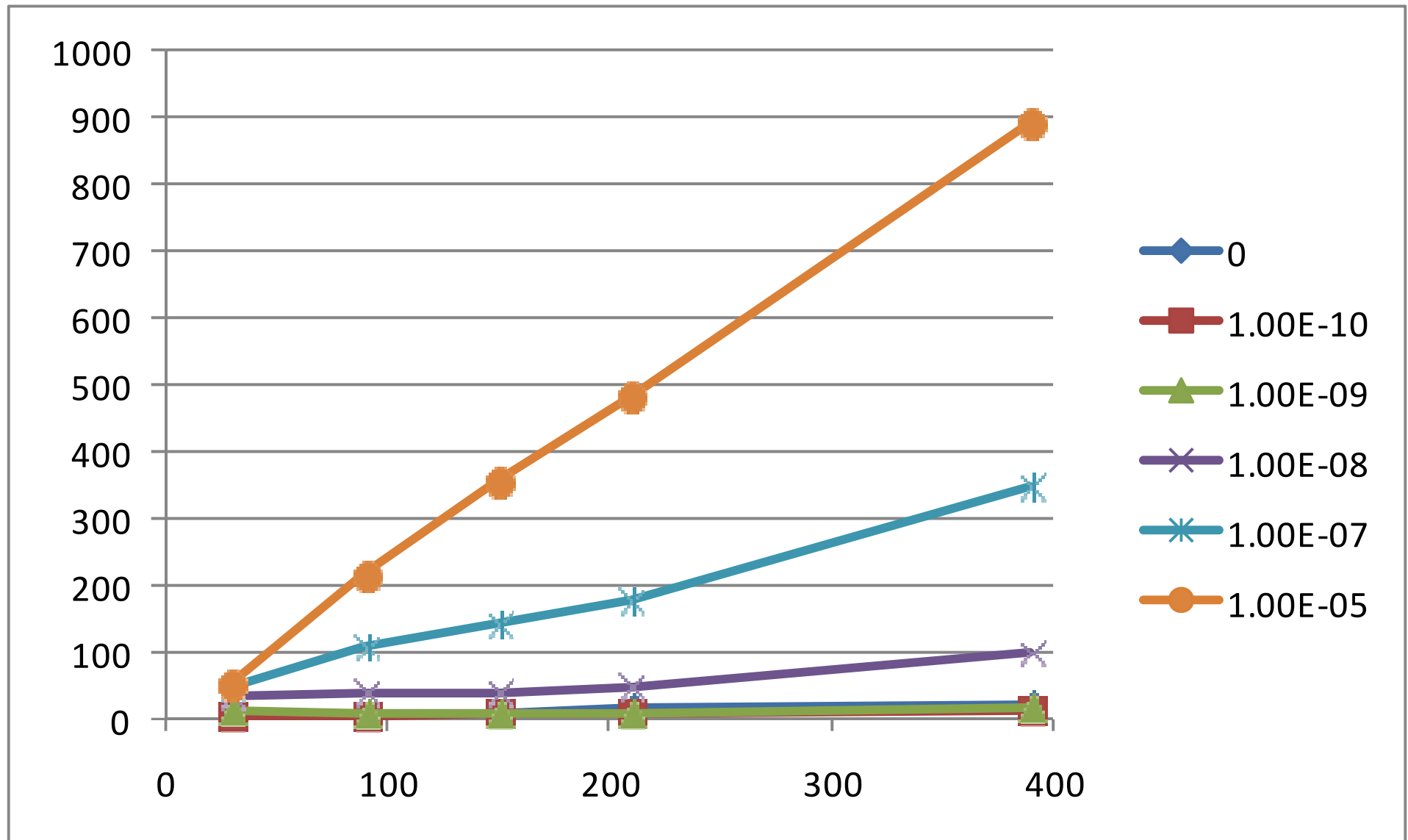

# 11+R+002 (K176128)

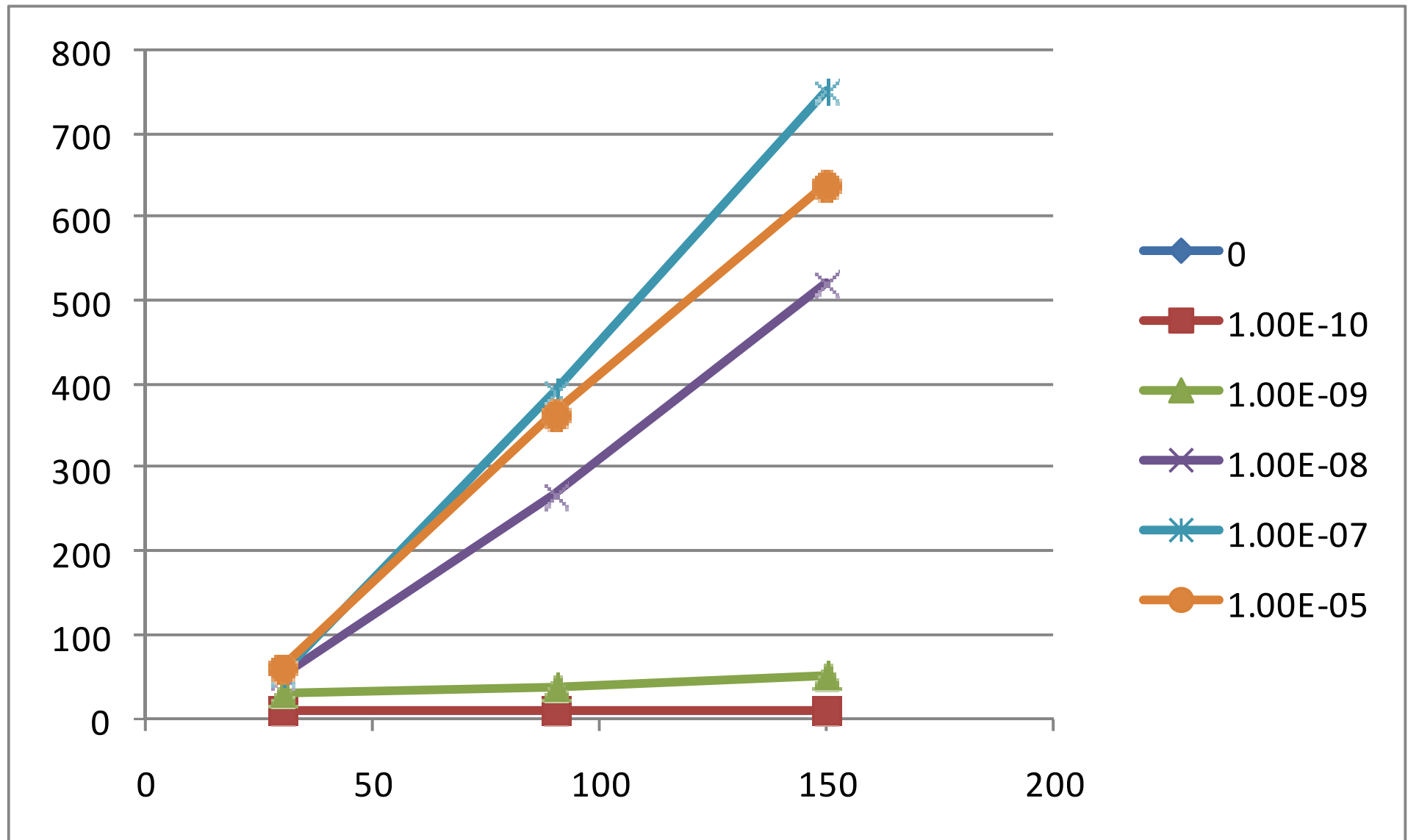



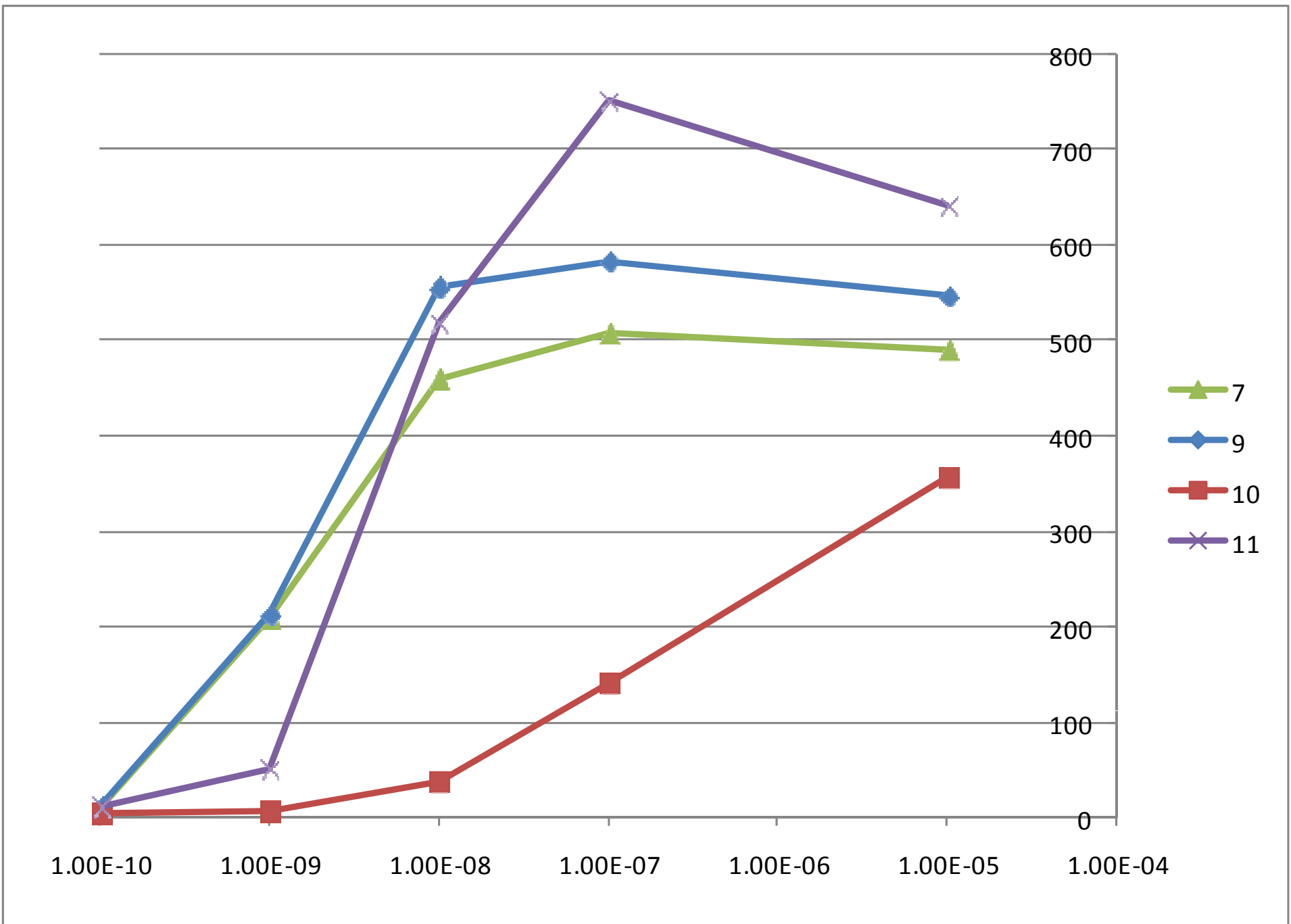

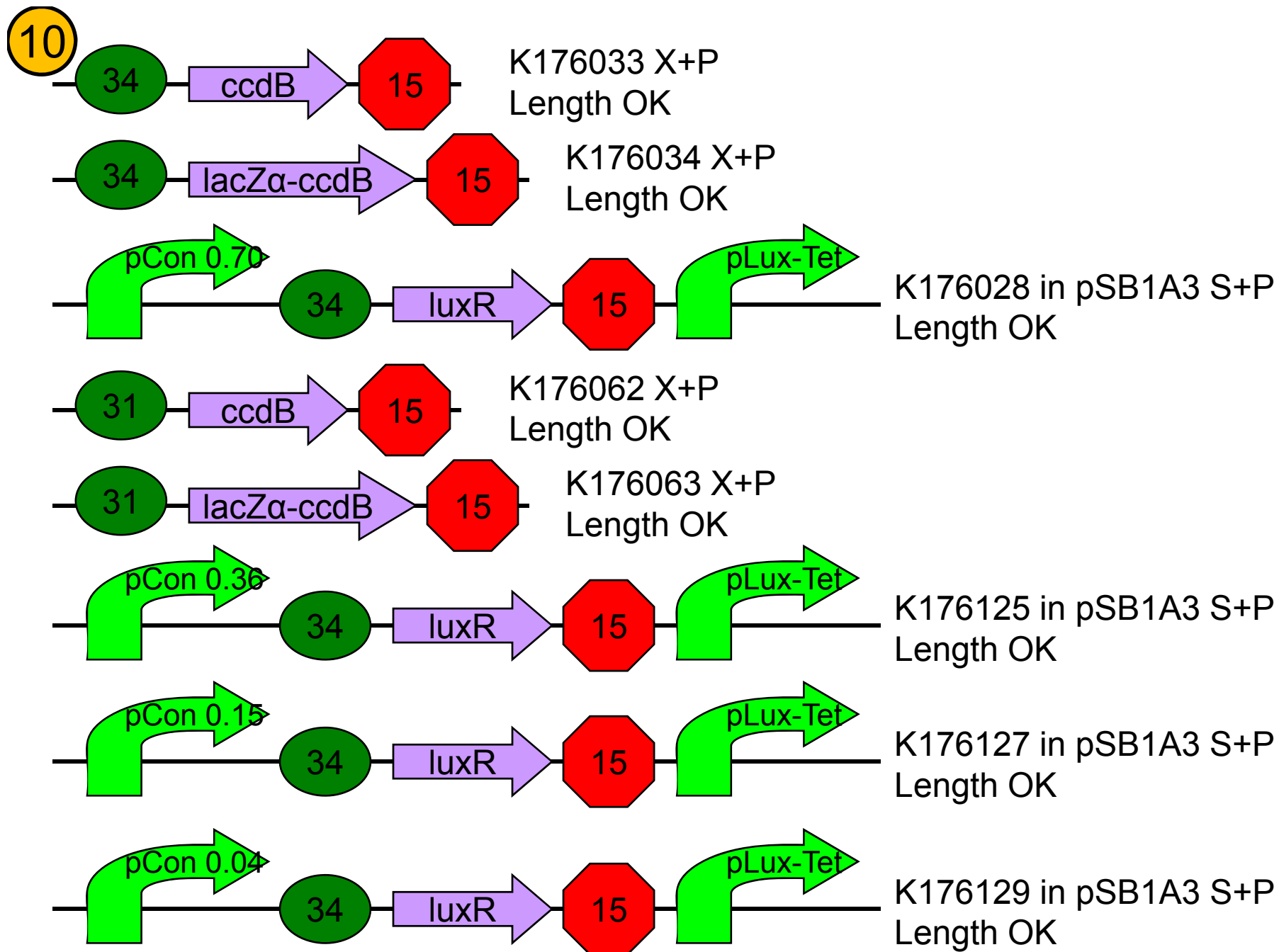

← VRccdB K176058  
Synthesis OK

← M13-47 K176059  
Synthesis OK

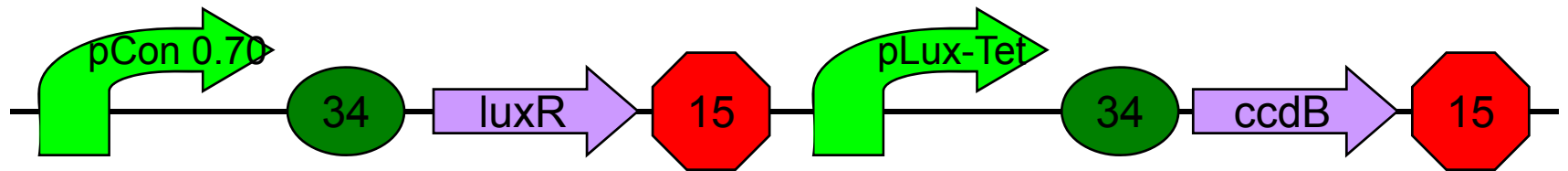

K176035 in pSB1A3 in DB3.1  
Sequence ?

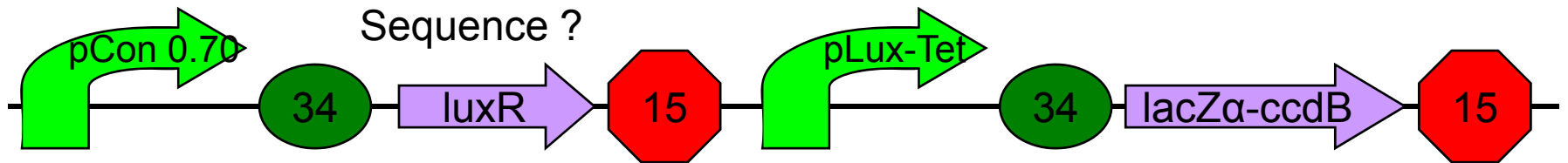

K176036 in pSB1A3 in DB3.1  
Sequence OK

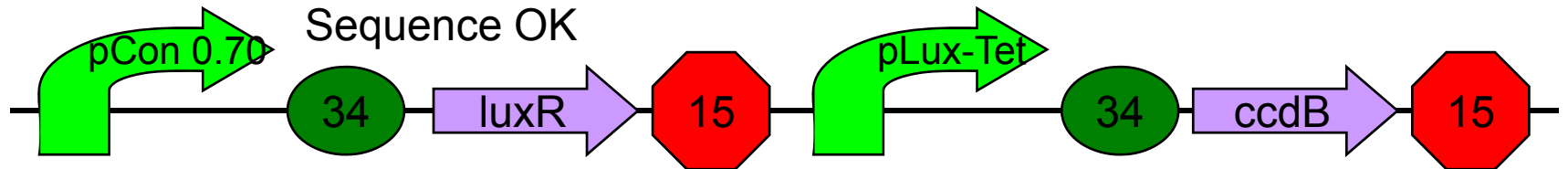

K176035 in pSB1A3 in TOP10  
Transformation Fail

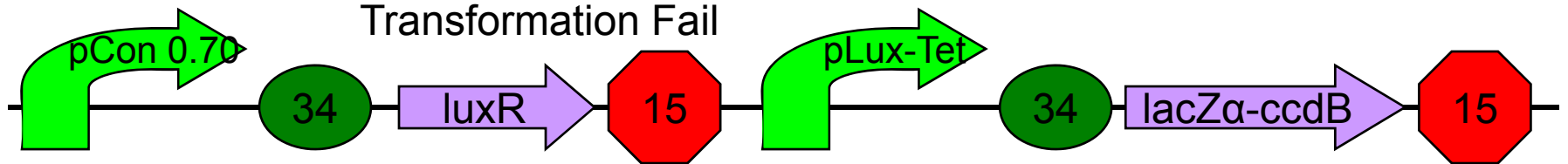

K176036 in pSB1A3 in TOP10  
Transformation Fail

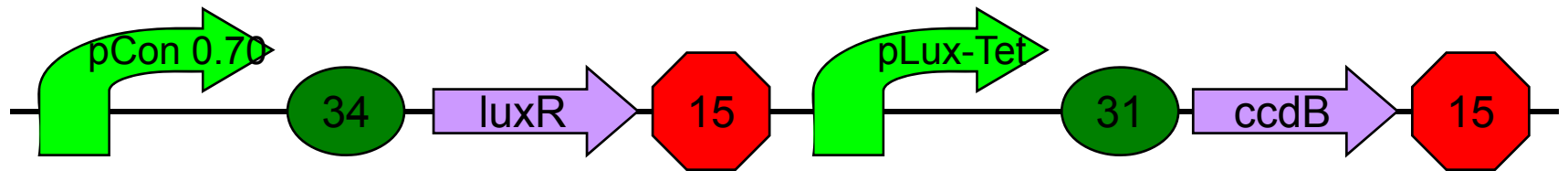

K176089 in pSB1A3 in DB3.1

Sequencing

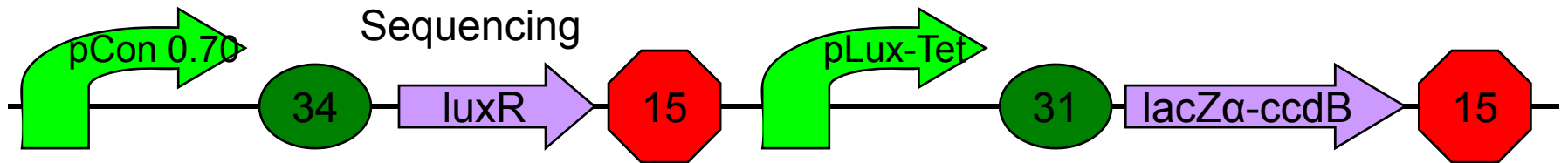

K176090 in pSB1A3 in DB3.1

Sequence ?

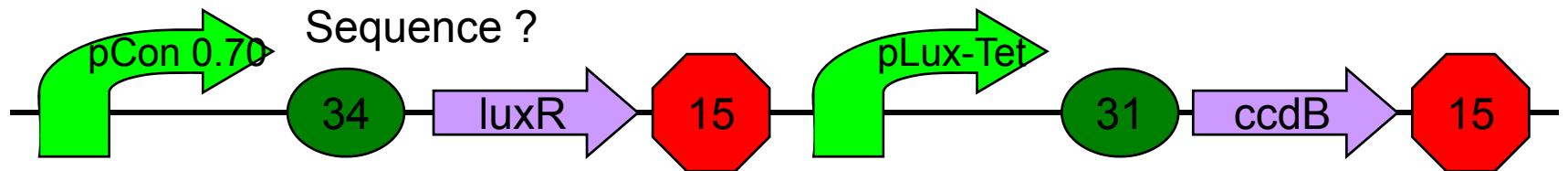

K176089 in pSB1A3 in TOP10

Transformation

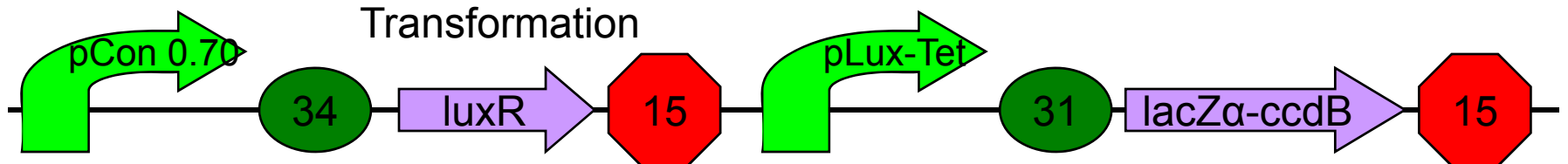

K176090 in pSB1A3 in TOP10

Transformation

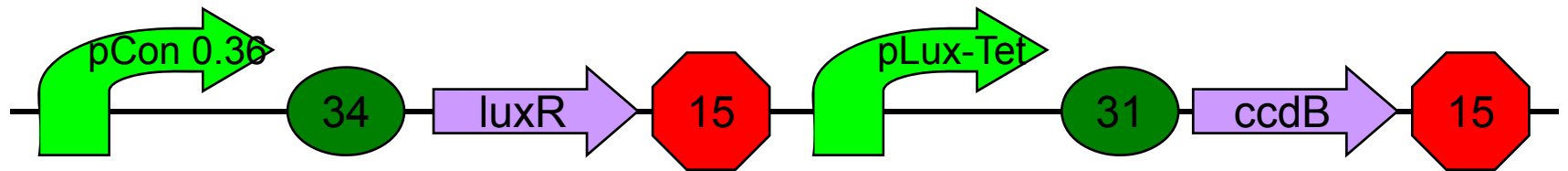

K176131 in pSB1A3 in DB3.1

Sequencing

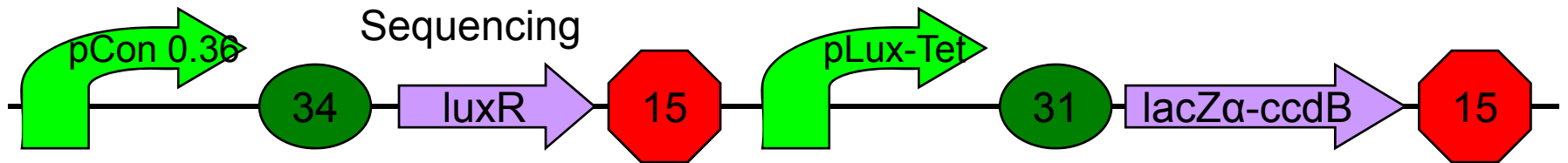

K176132 in pSB1A3 in DB3.1

Sequencing

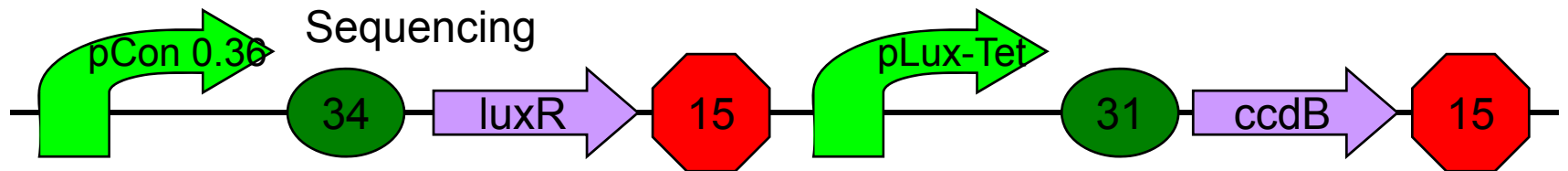

K176131 in pSB1A3 in MDS42rB

Transformation

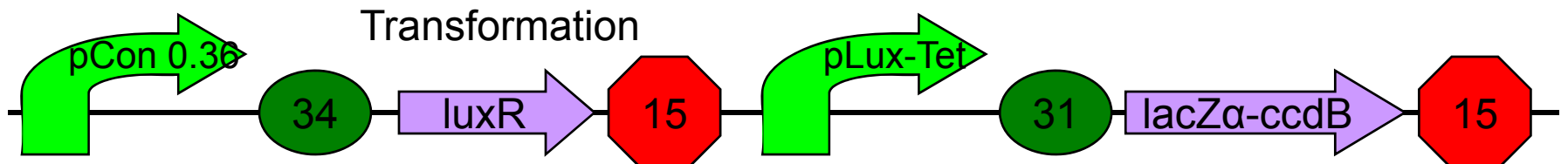

K176132 in pSB1A3 in MDS42rB

Transformation

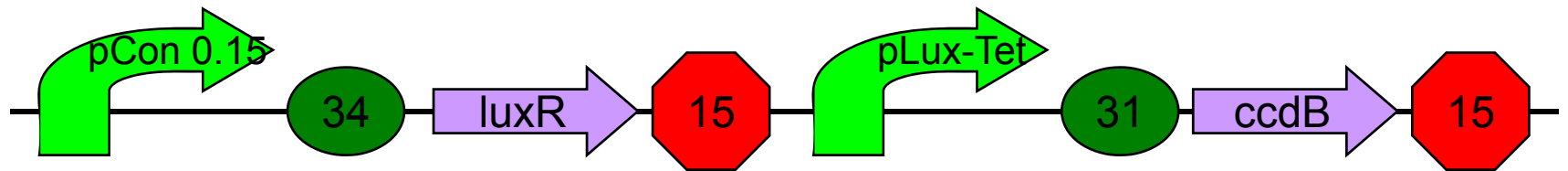

K176185 in pSB1A3 in DB3.1

Sequencing

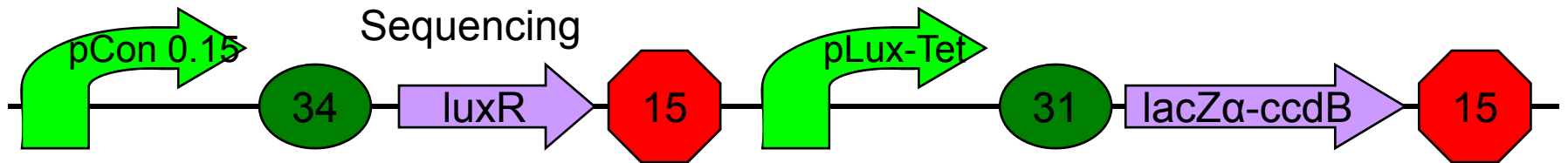

K176186 in pSB1A3 in DB3.1

Sequencing

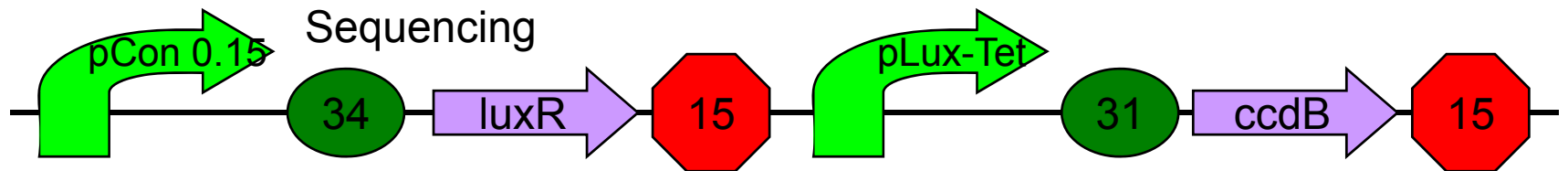

K176185 in pSB1A3 in MDS42rB

Transformation

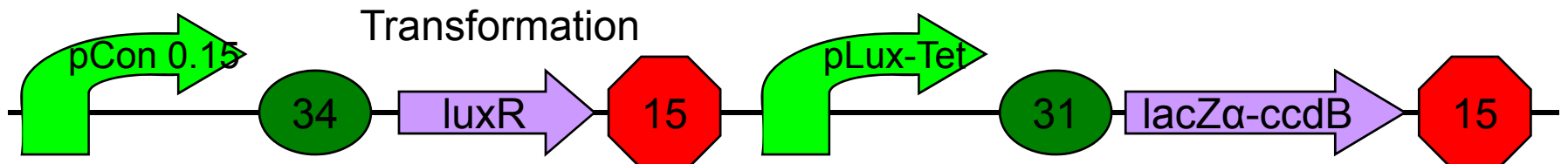

K176186 in pSB1A3 in MDS42rB

Transformation

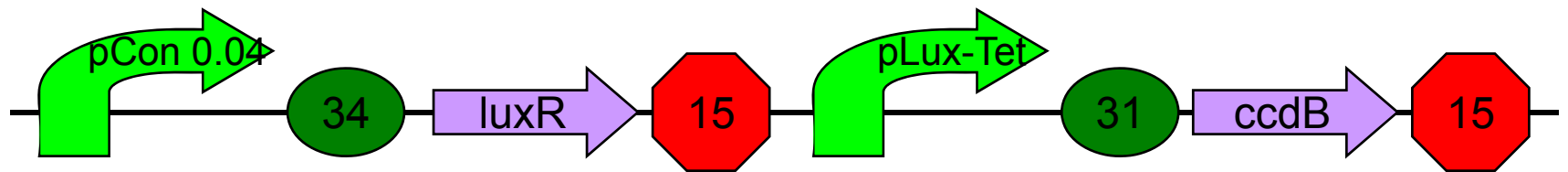

K176187 in pSB1A3 in DB3.1

Sequencing

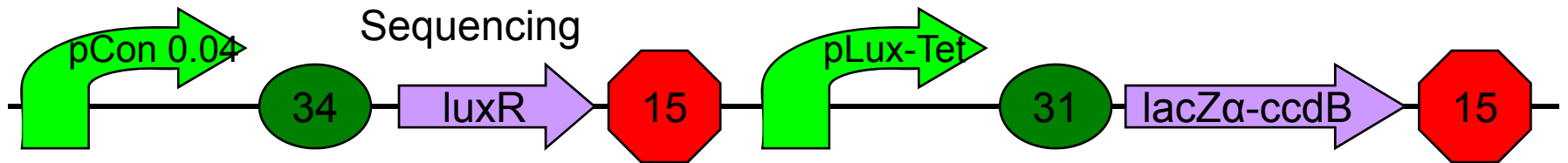

K176188 in pSB1A3 in DB3.1

Sequencing

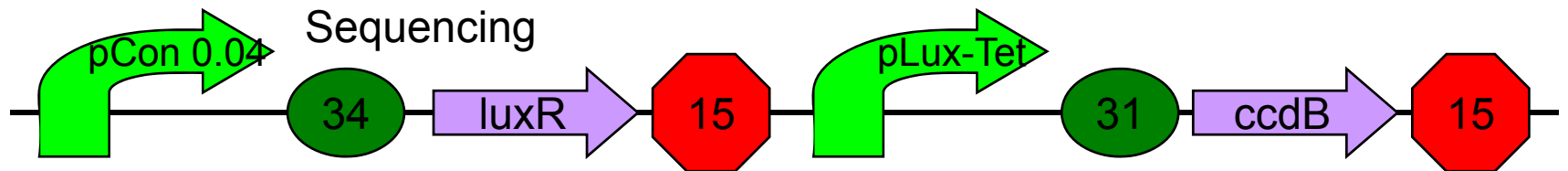

K176187 in pSB1A3 in MDS42rB

Transformation

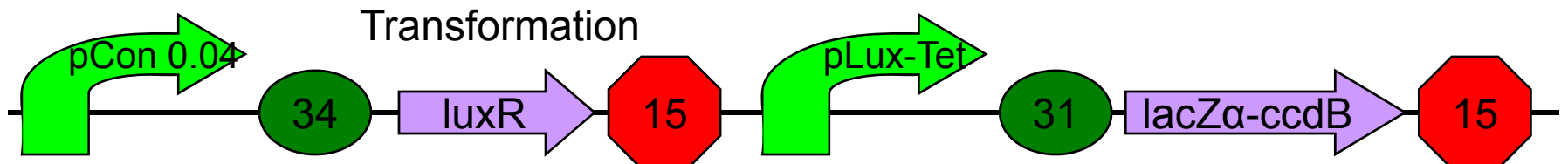

K176188 in pSB1A3 in MDS42rB

Transformation

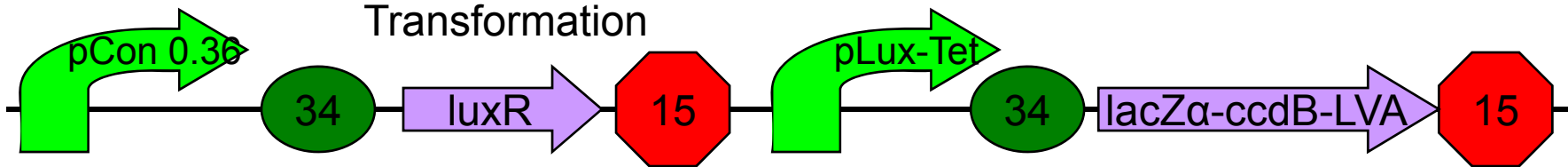
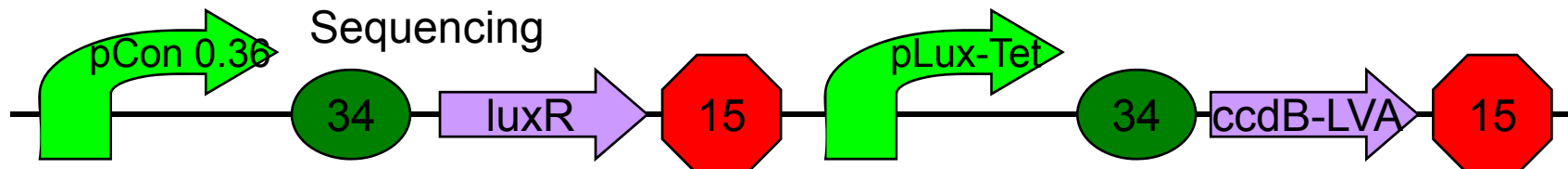
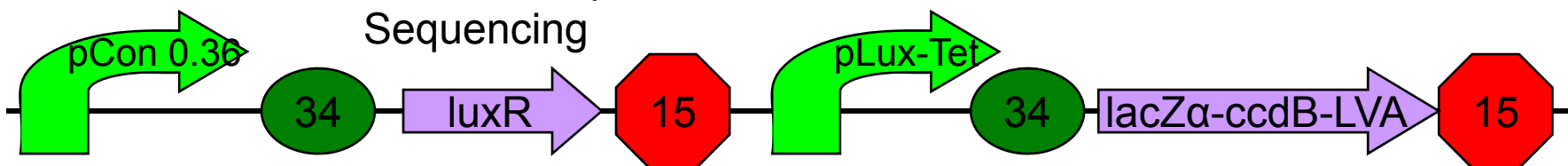
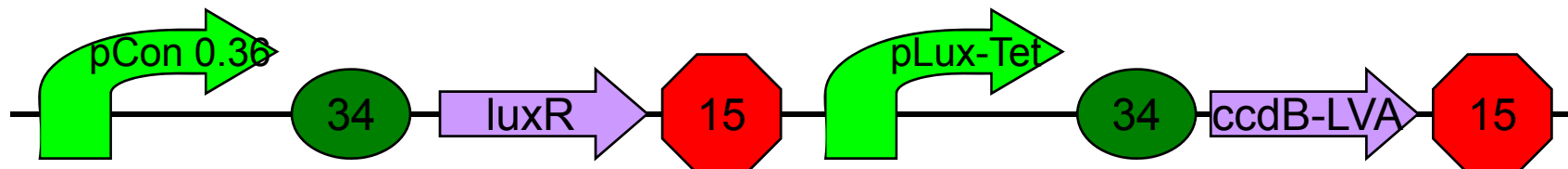
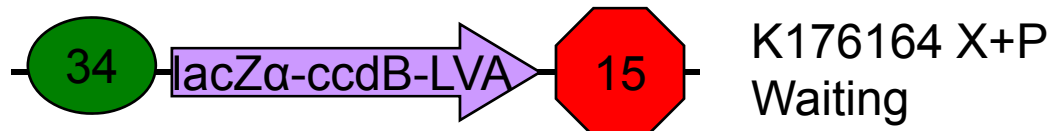
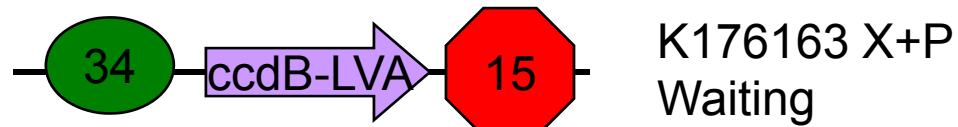



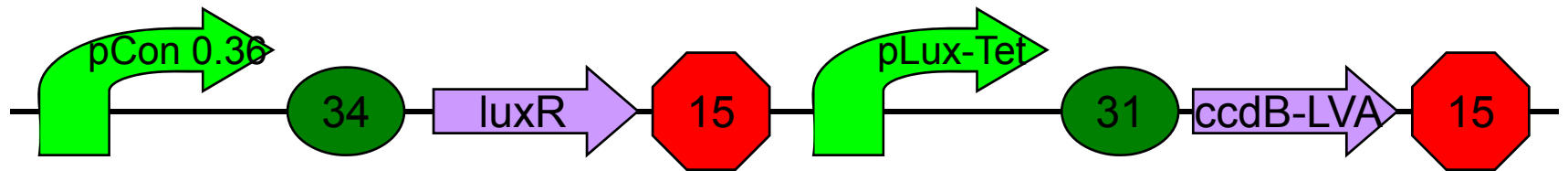
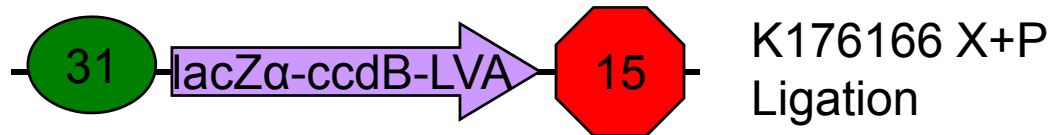
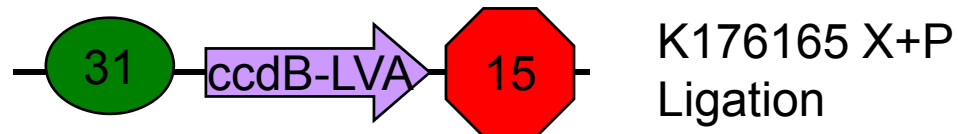

K176169 in pSB1A3 in DB3.1  
Sequencing

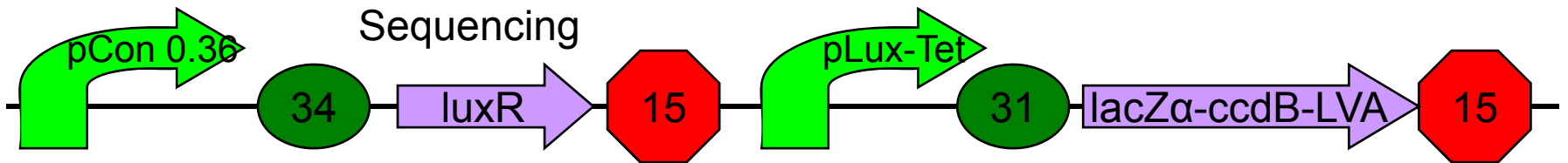

K176170 in pSB1A3 in DB3.1  
Sequencing

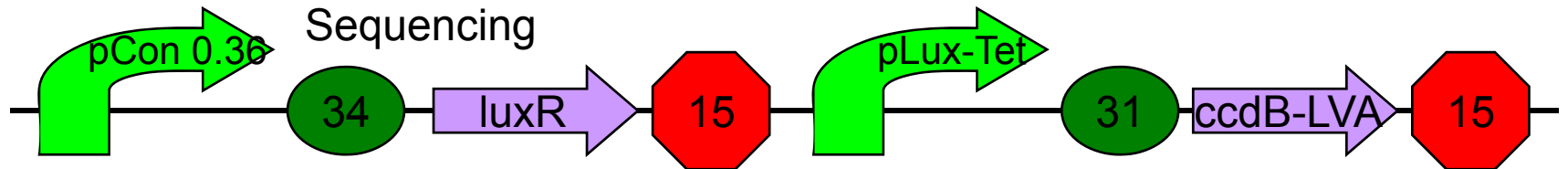

K176169 in pSB1A3 in MDS42rB  
Transformation

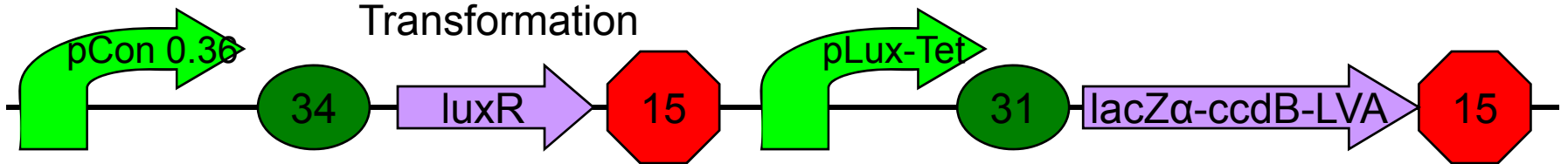

K176170 in pSB1A3 in MDS42rB  
Transformation

11

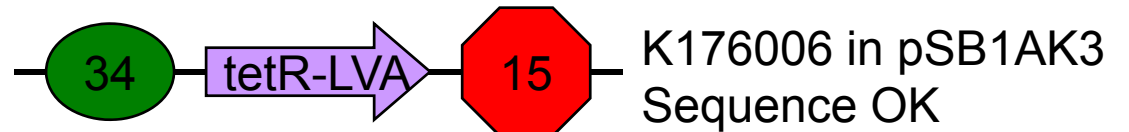
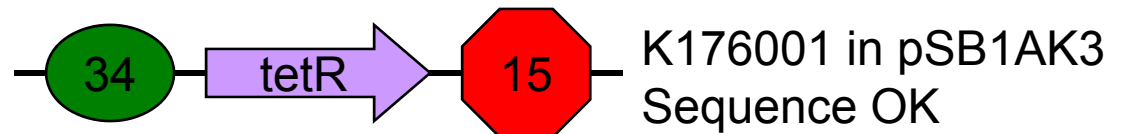
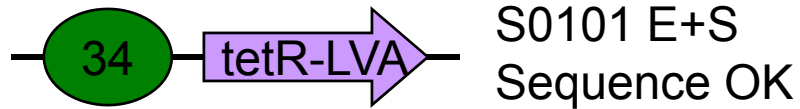
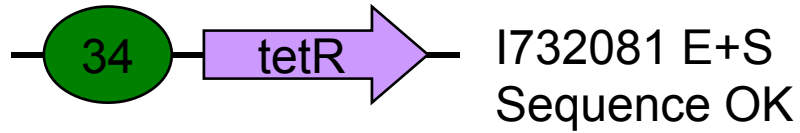
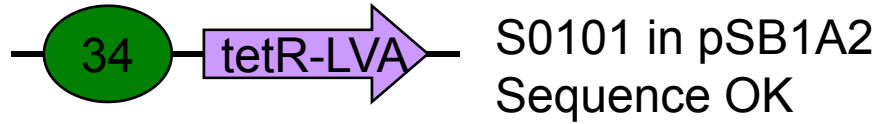
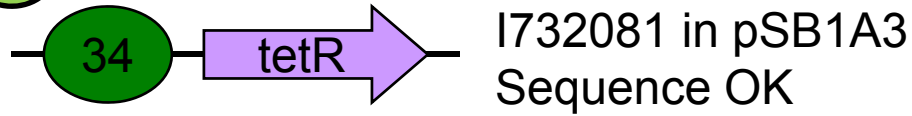

12

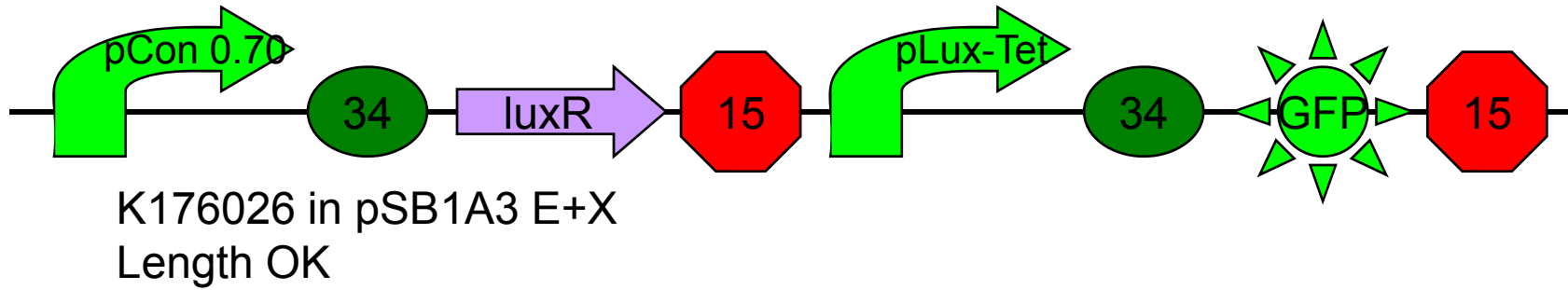
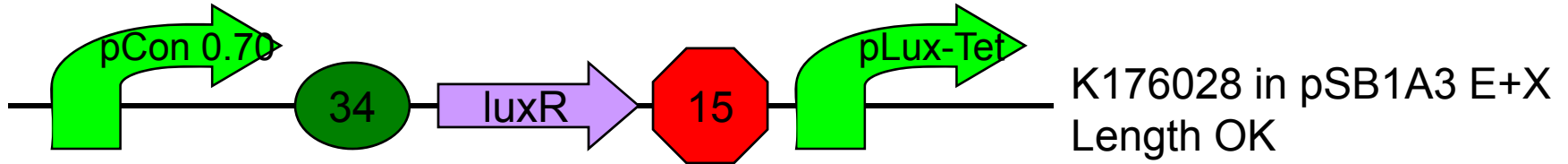
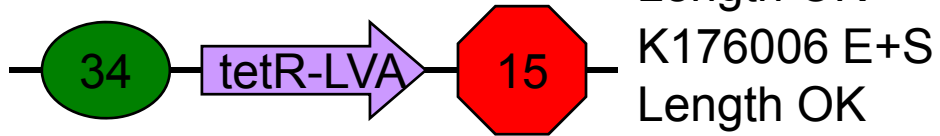
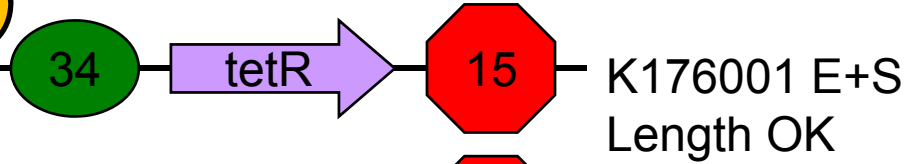



K176057  
Synthesis OK

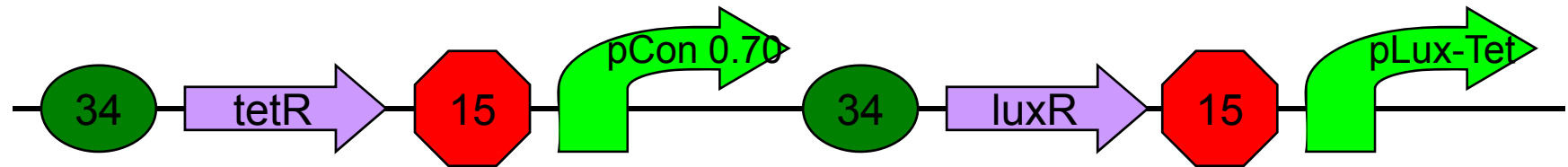

K176031 in pSB1A3  
Sequence OK

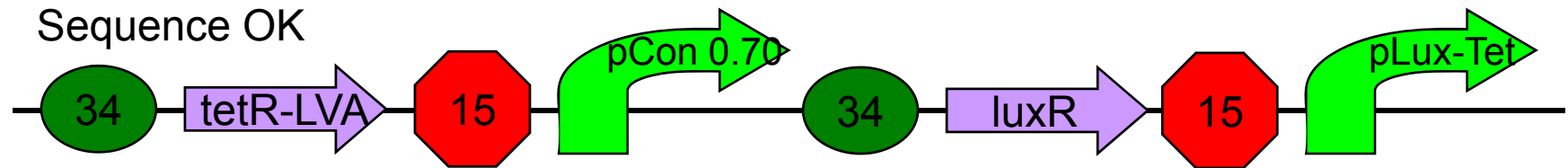

K176032 in pSB1A3  
Sequence OK

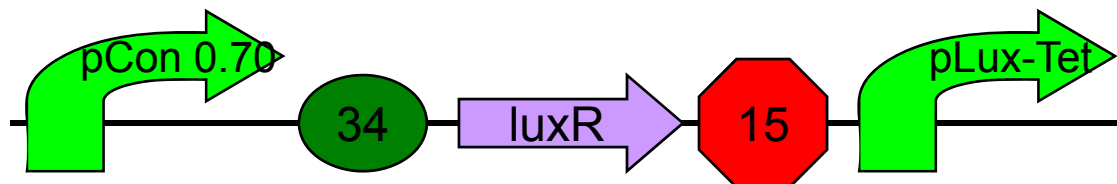
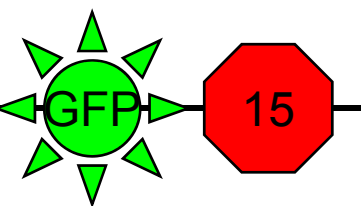
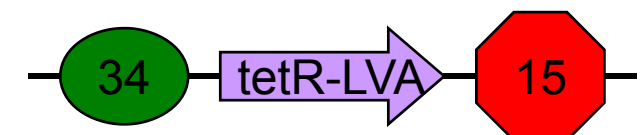
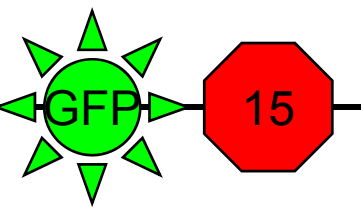
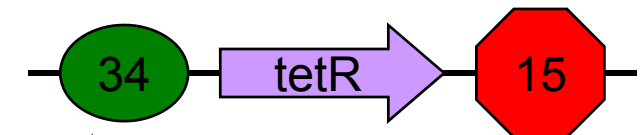

K176029 in pSB1A3  
Sequence ?

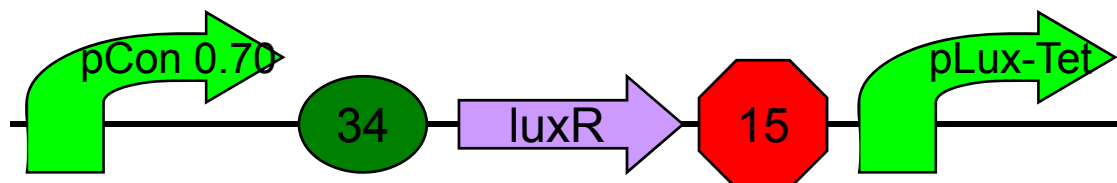

K176030 in pSB1A3  
Sequence ?

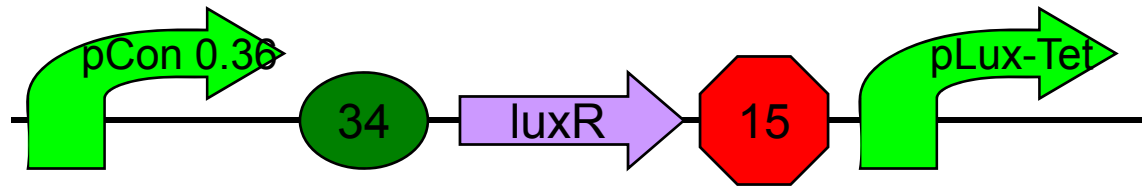

K176125 in pSB1A3  
Digestion

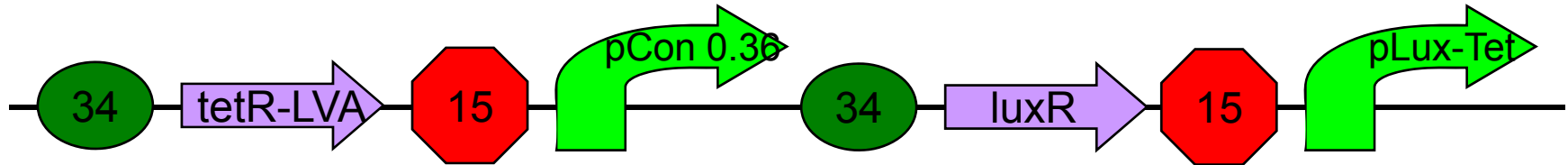

K176133 in pSB1A3  
Ligation

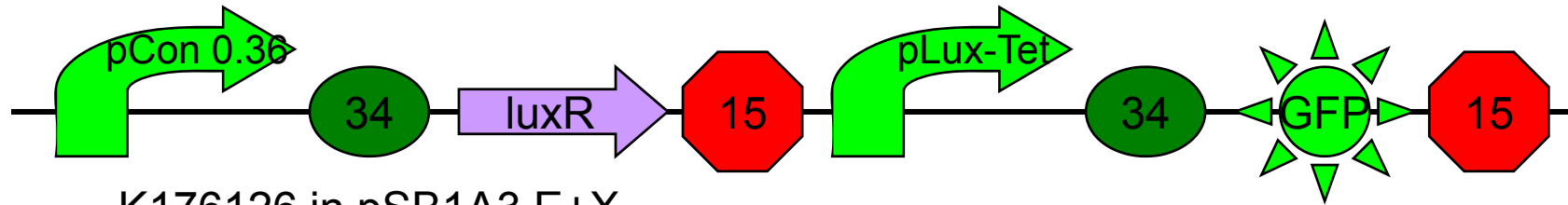

K176126 in pSB1A3 E+X  
Length OK

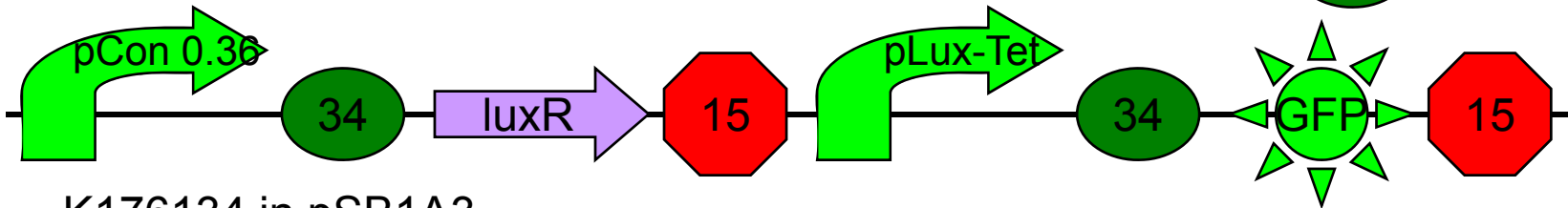

K176134 in pSB1A3  
Sequencing

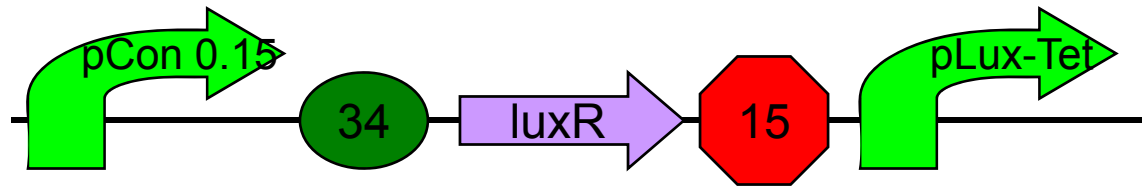

K176127 in pSB1A3  
Digestion

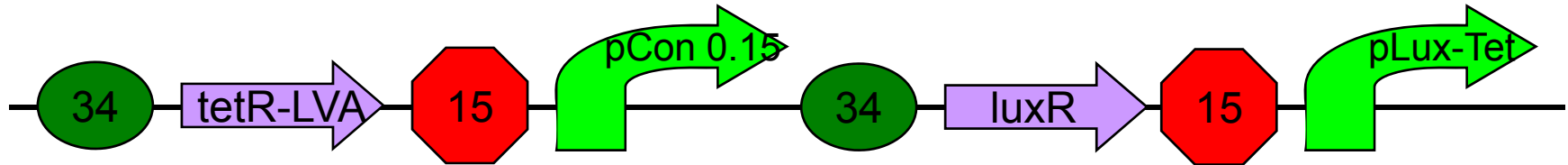

K176171 in pSB1A3  
Ligation

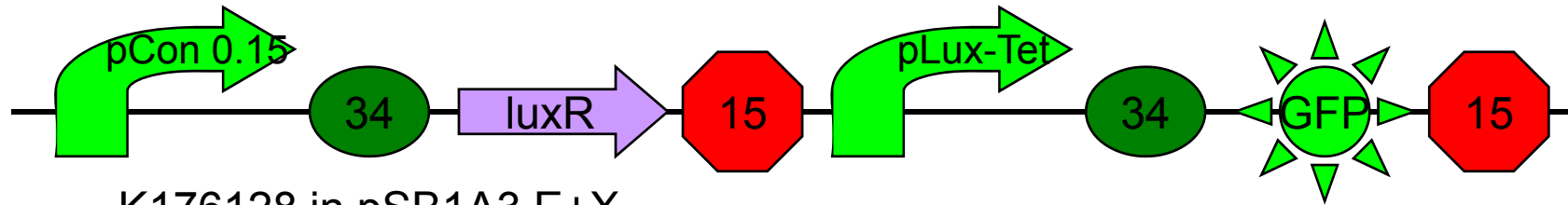

K176128 in pSB1A3 E+X  
Length OK

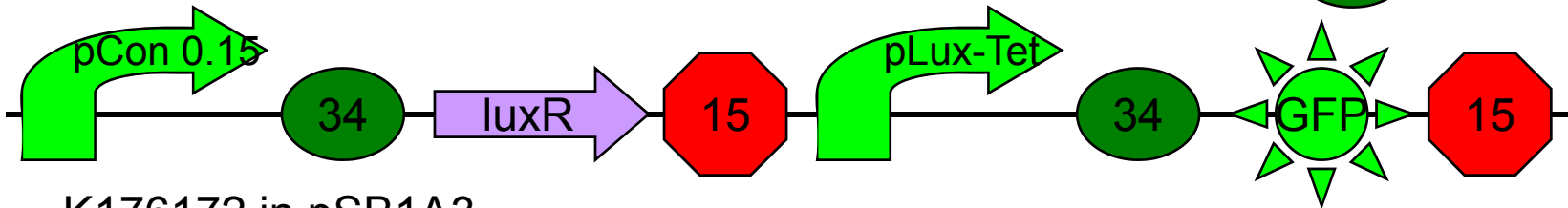

K176172 in pSB1A3  
Sequencing

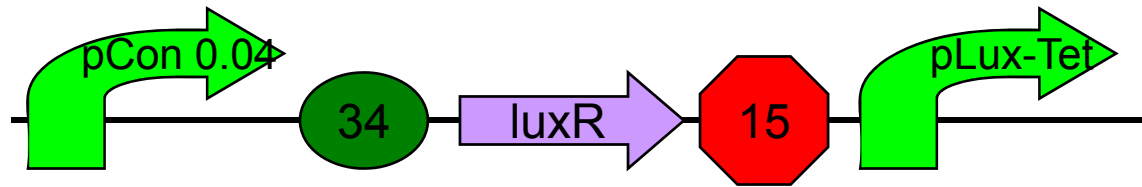

K176129 in pSB1A3  
Digestion

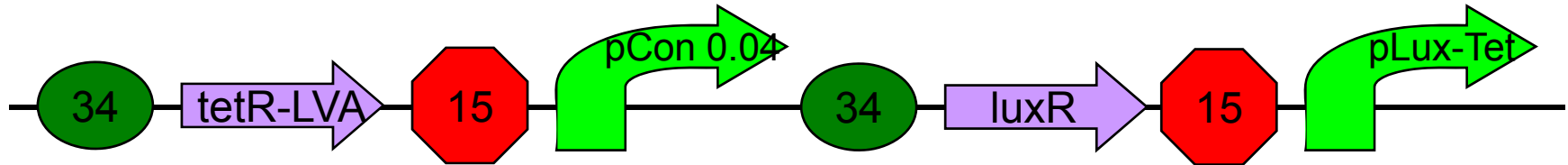

K176173 in pSB1A3  
Ligation

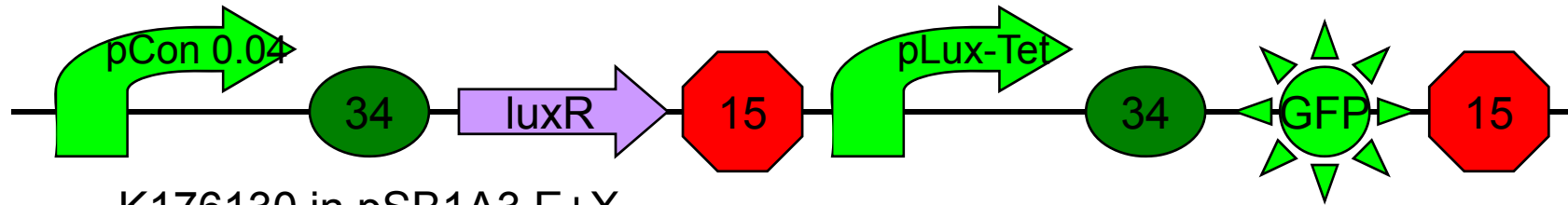

K176130 in pSB1A3 E+X  
Length OK

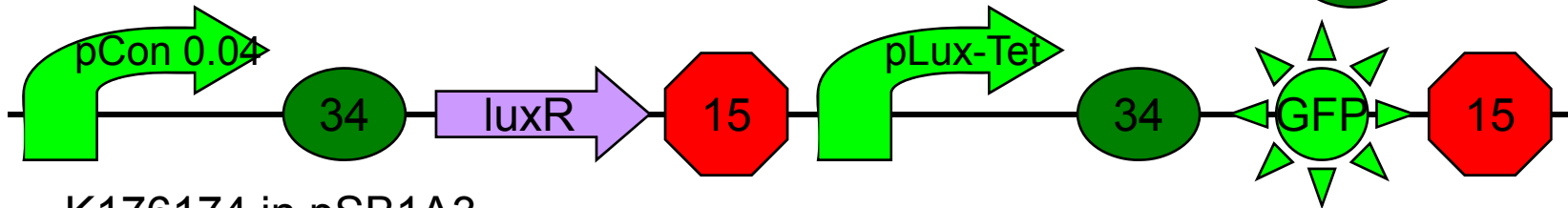

K176174 in pSB1A3  
Sequencing

13

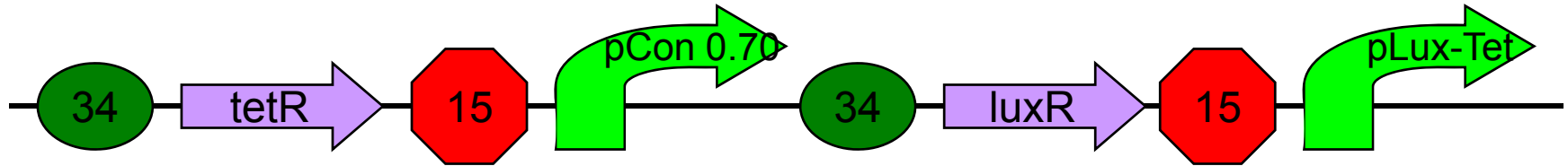

K176031 X+P  
Length OK

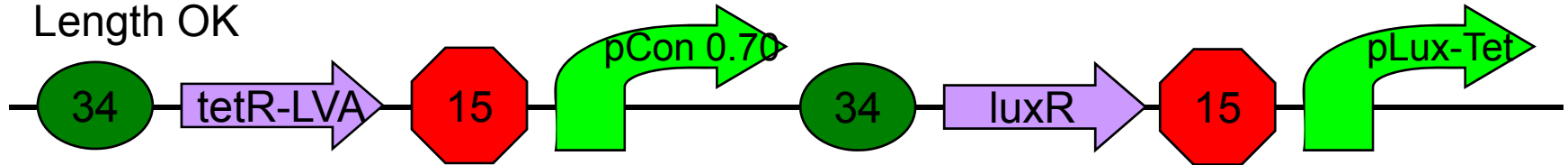

K176032 X+P  
Length OK

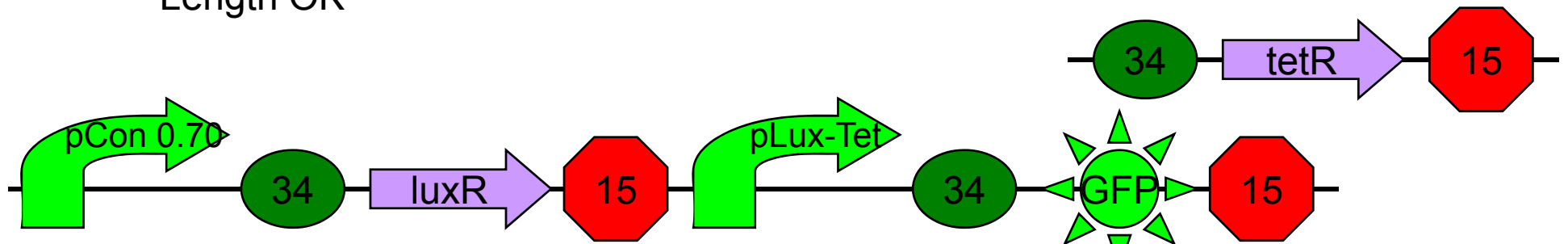

K176029 X+P  
Length OK

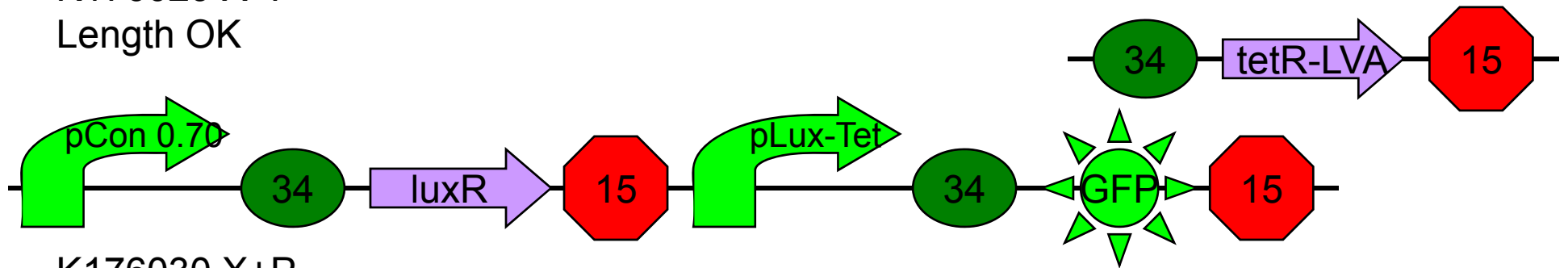

K176030 X+P  
Length OK



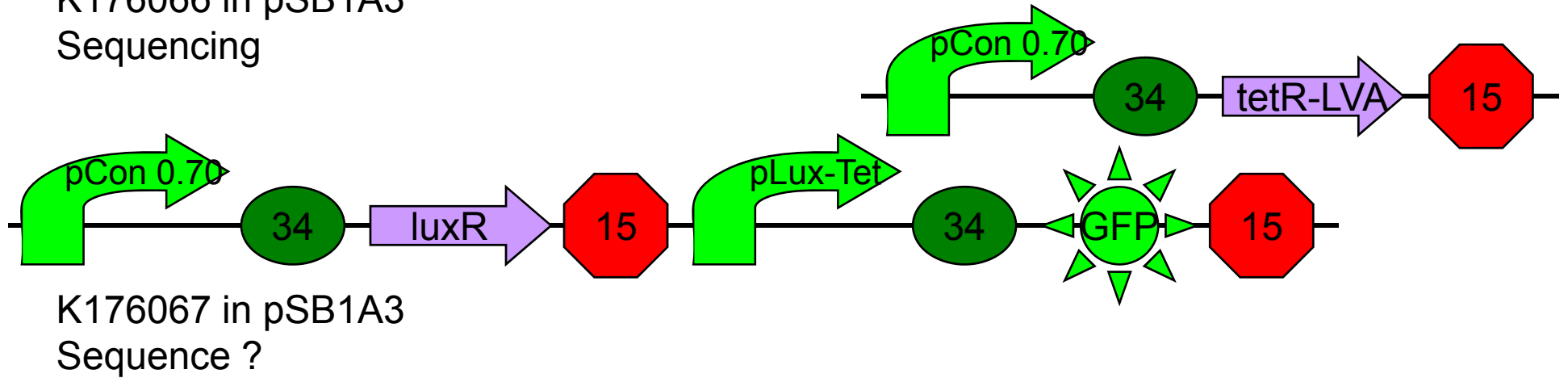
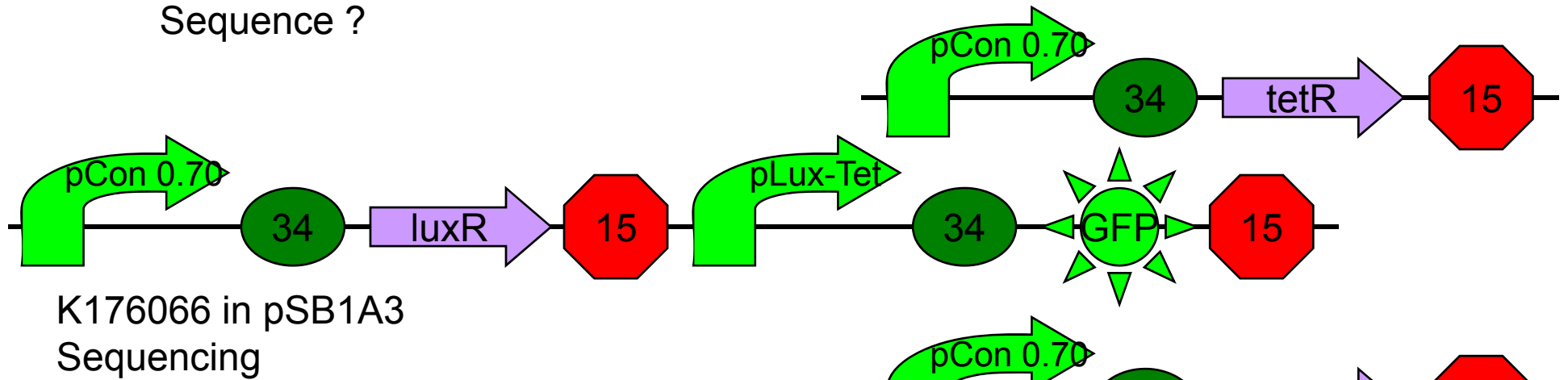
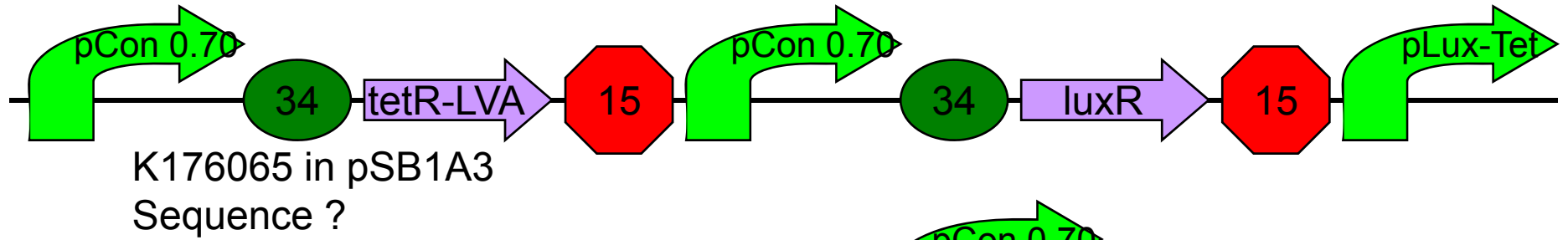
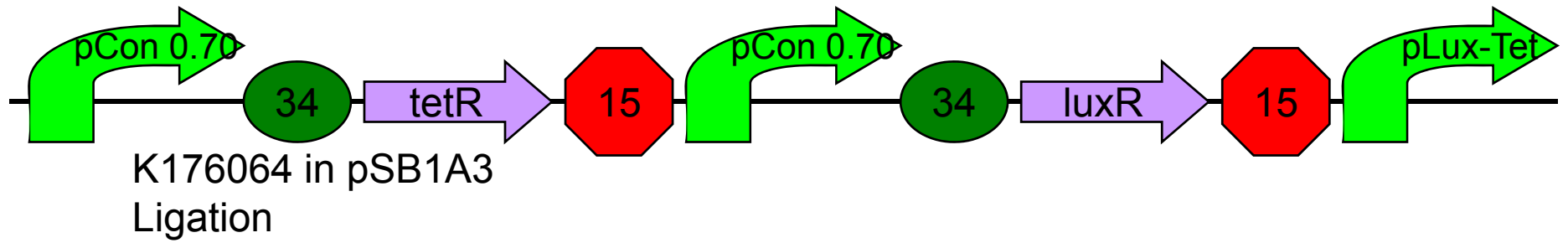

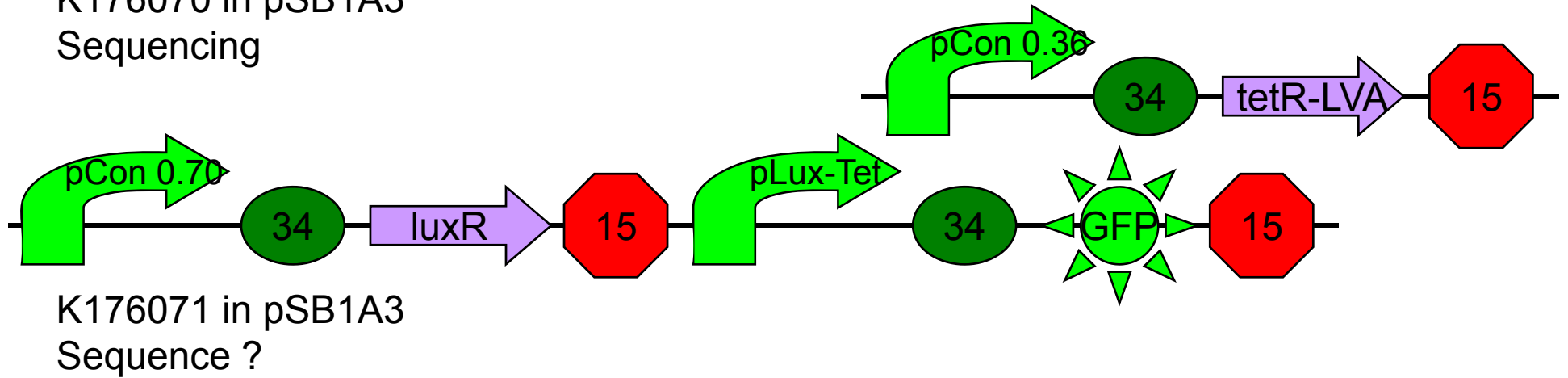
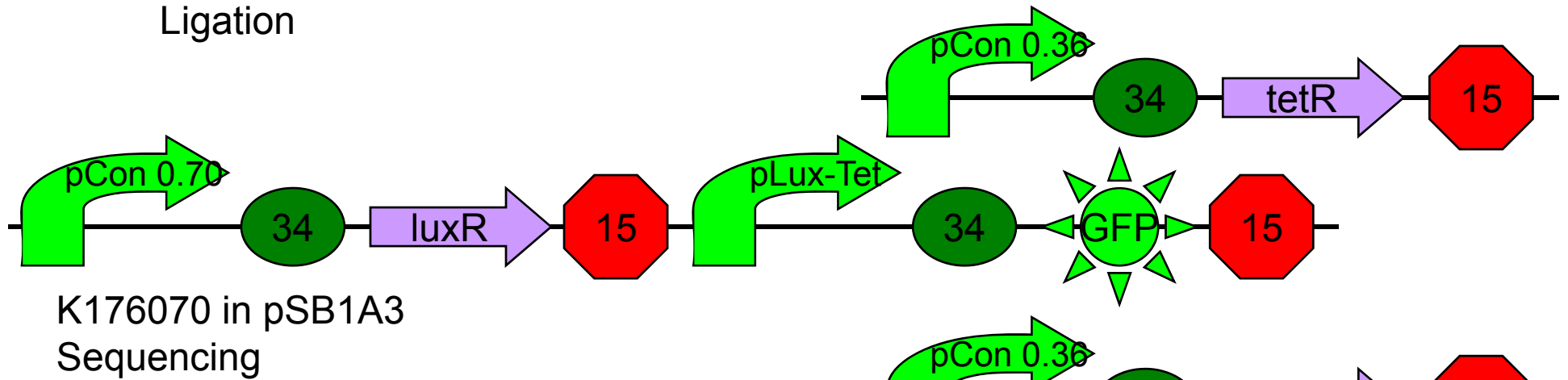
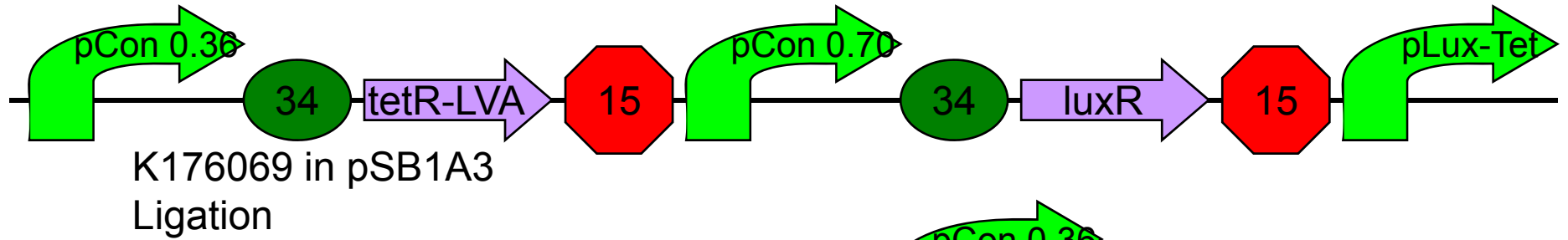
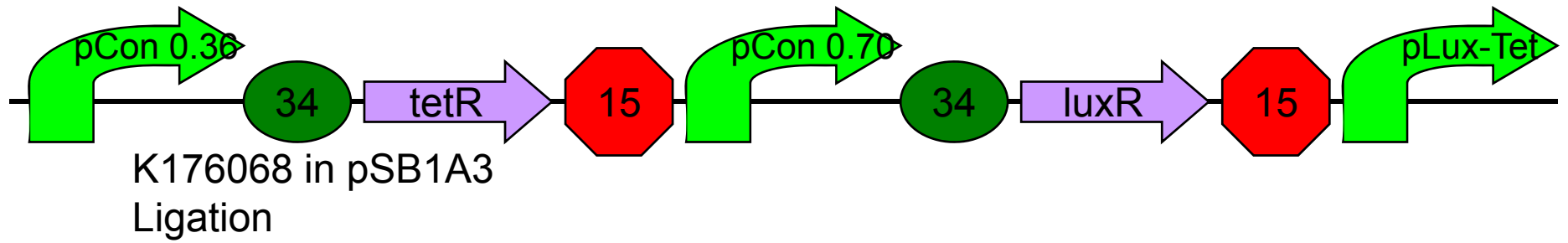

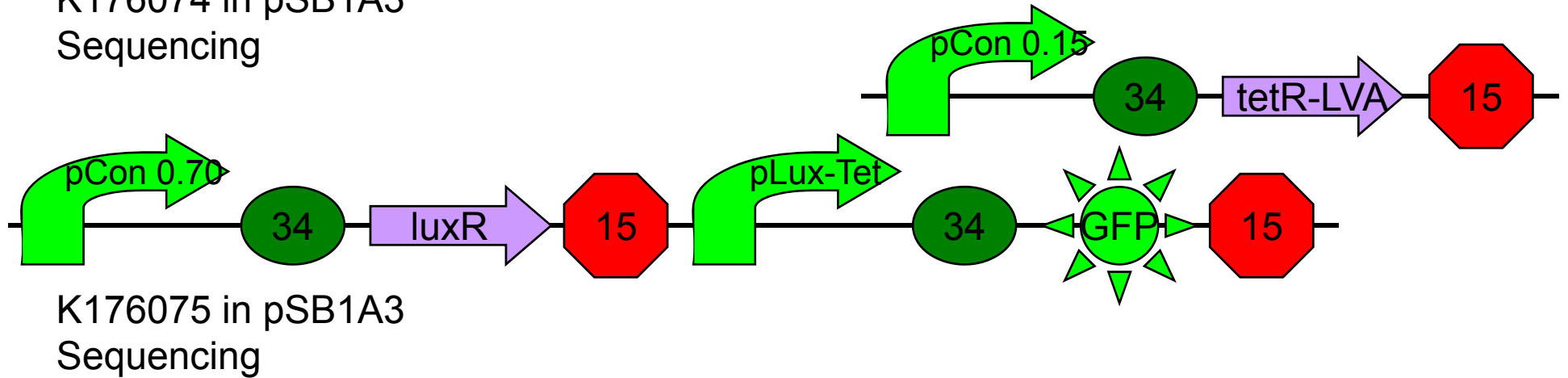
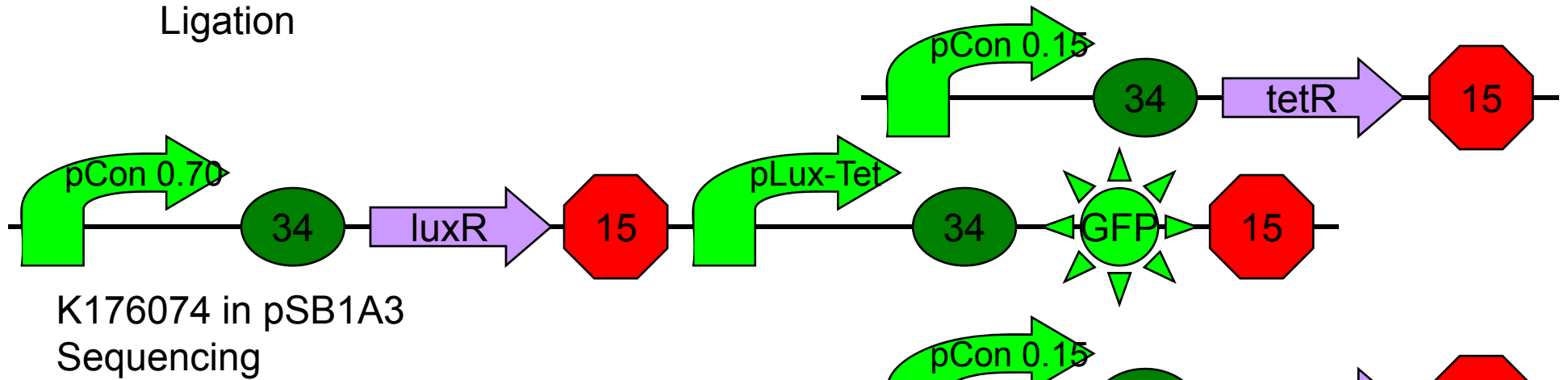
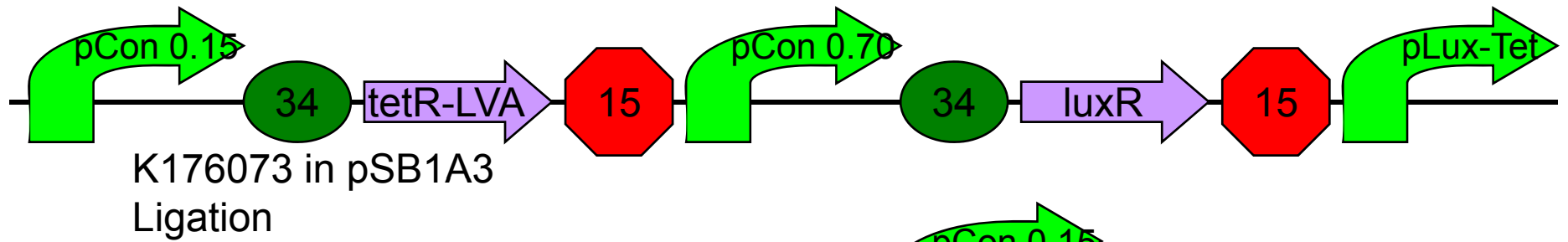
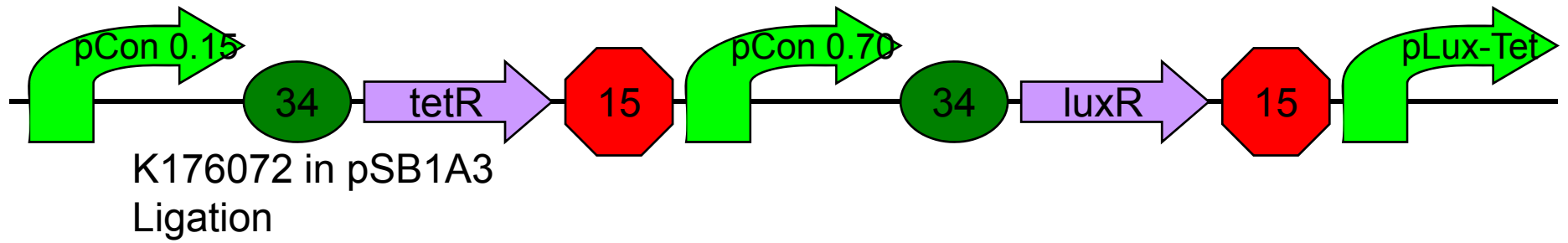

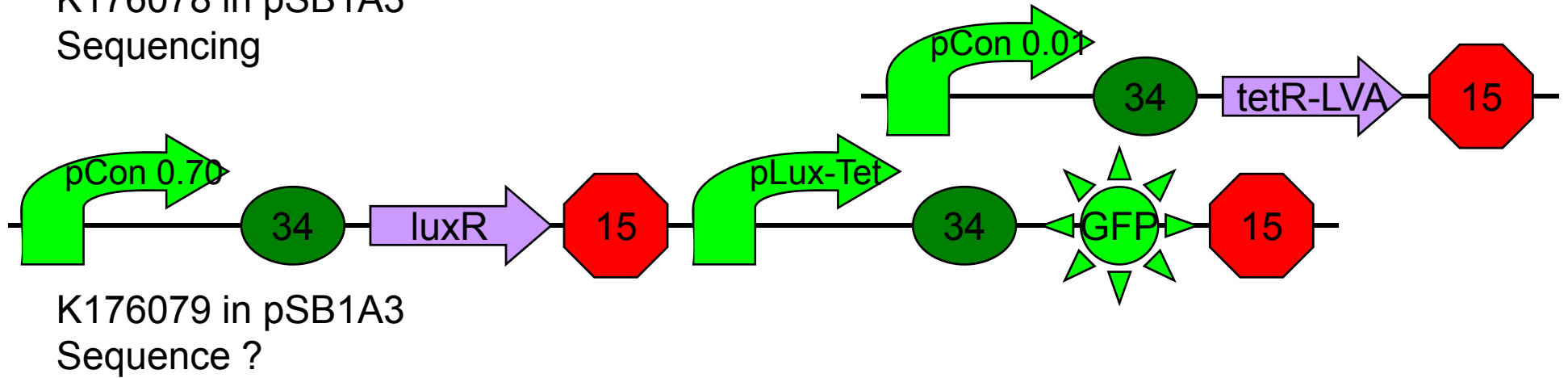
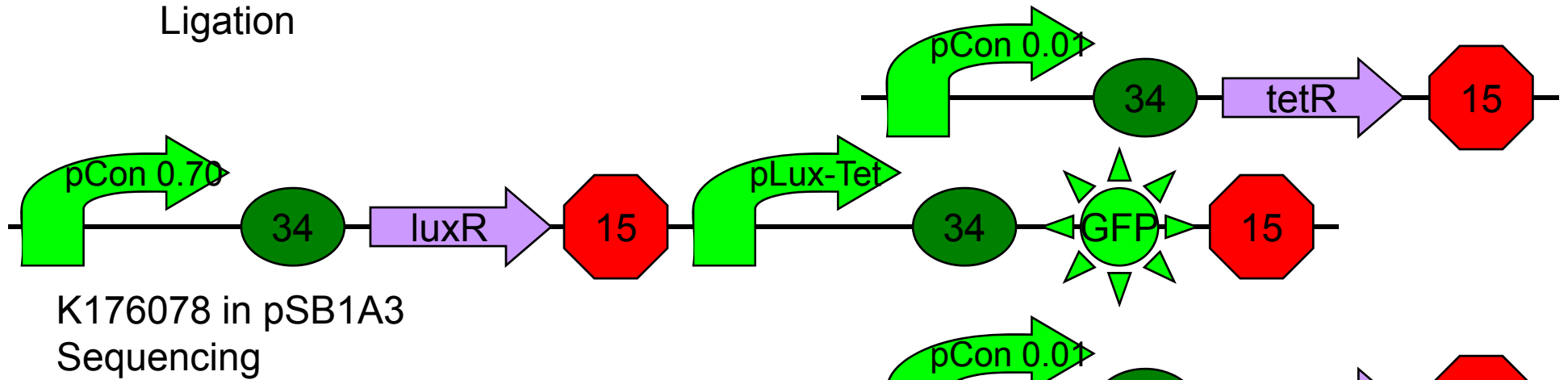
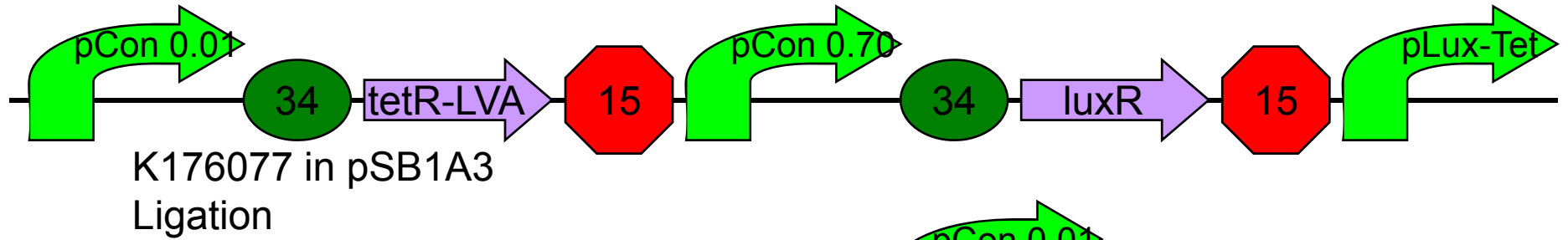
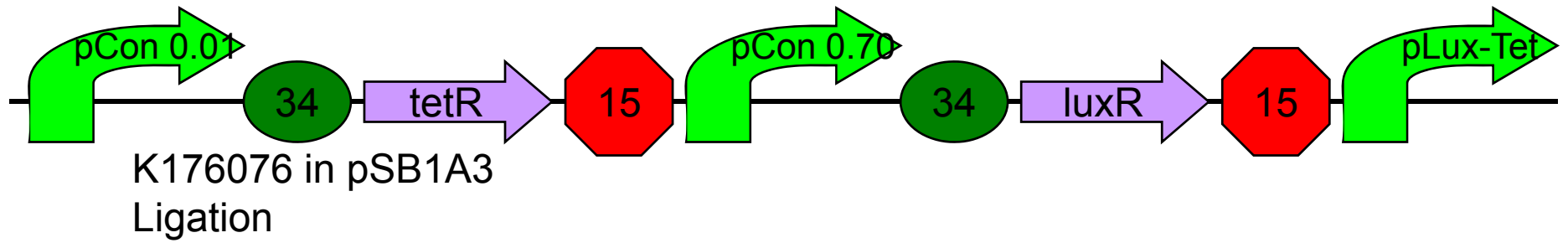



# K176067 (7+30)

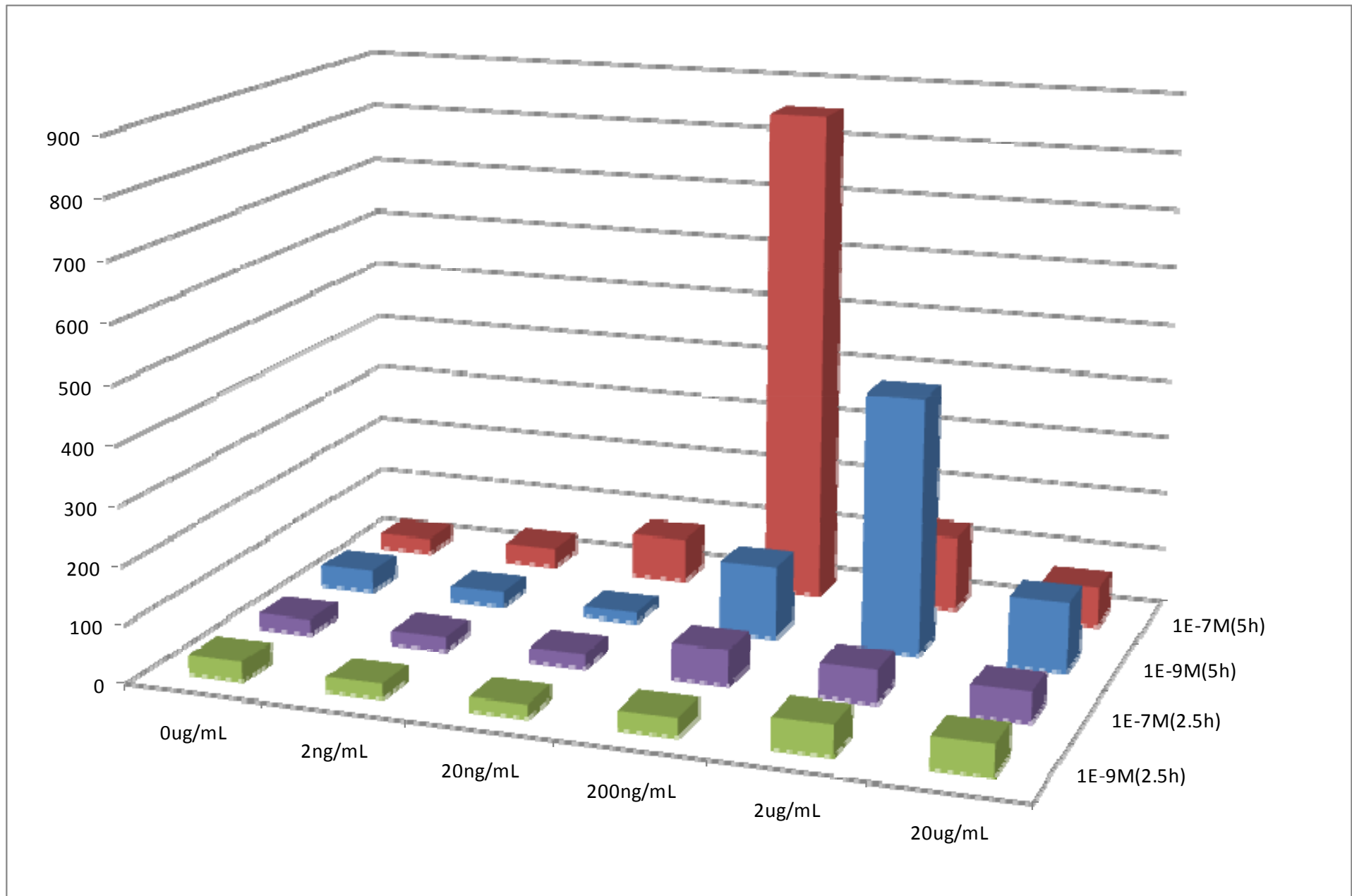

# K176070 (9+29)

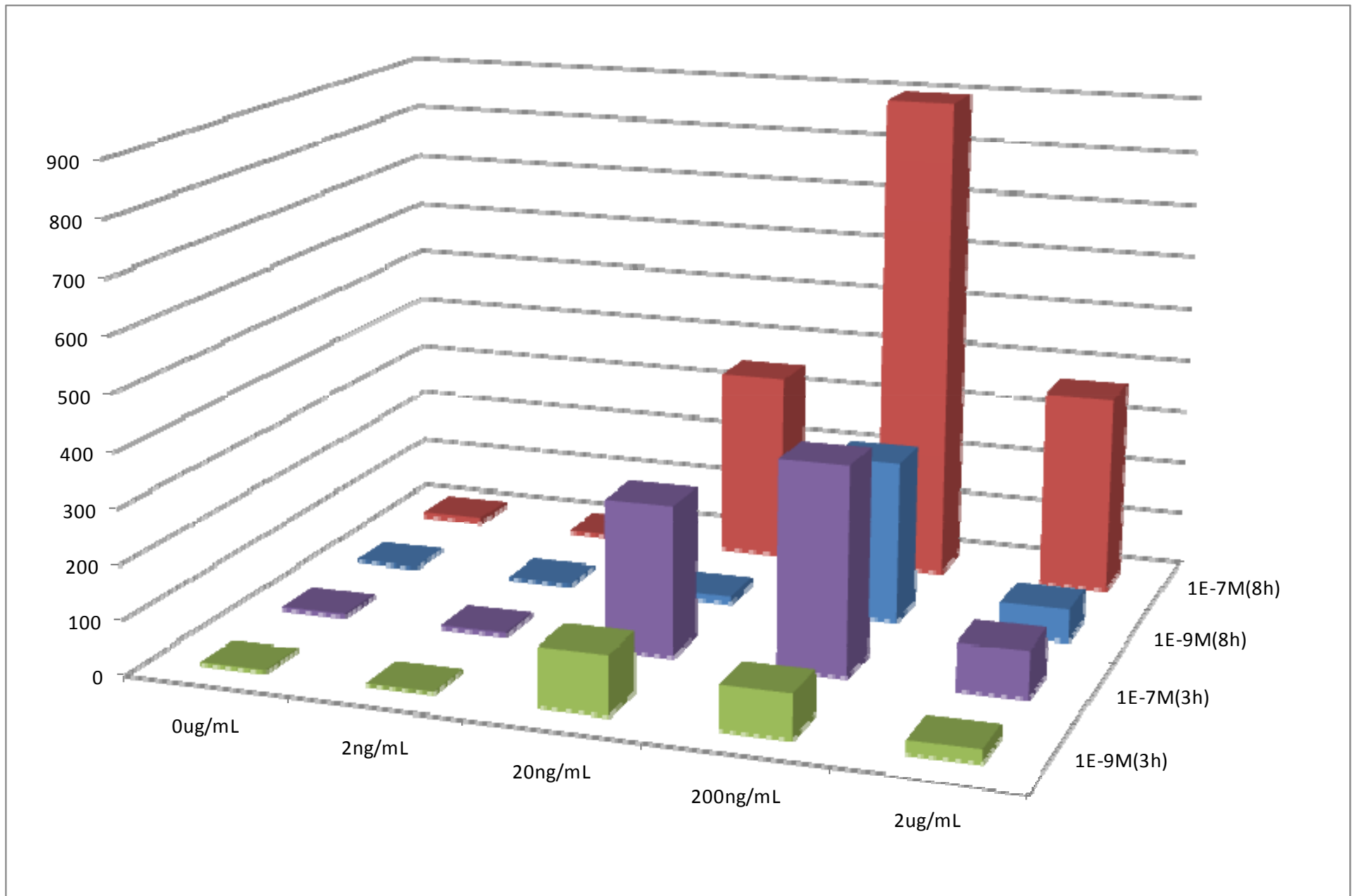

# K176071 (9+30)

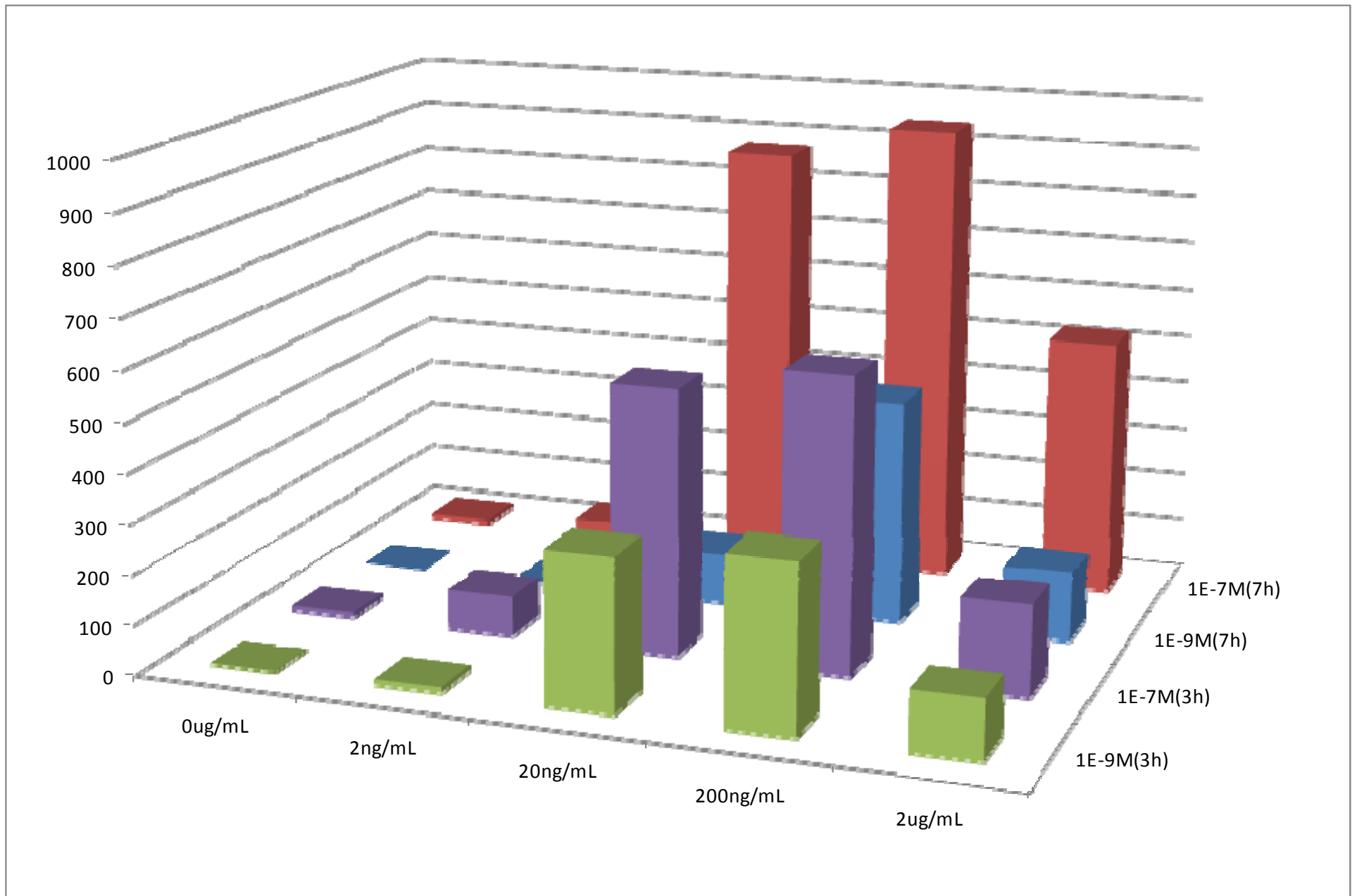



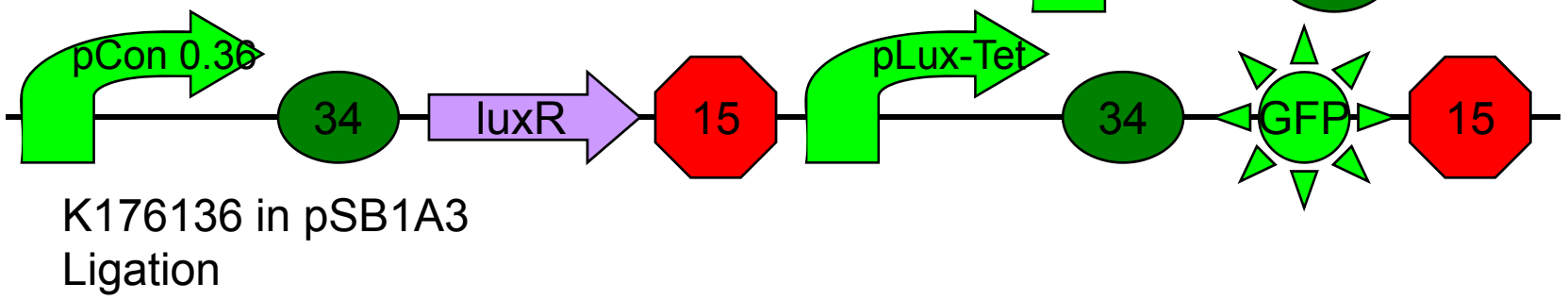
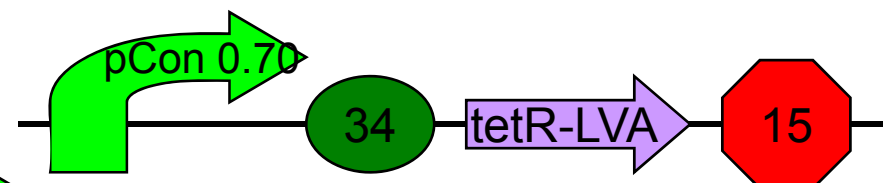
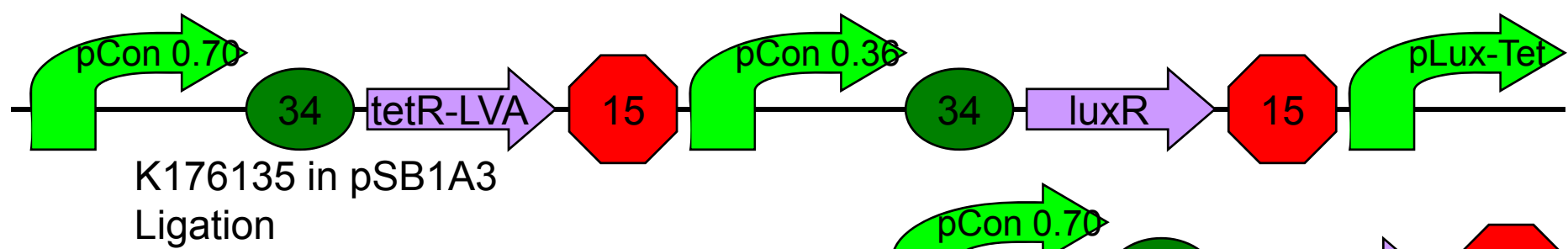
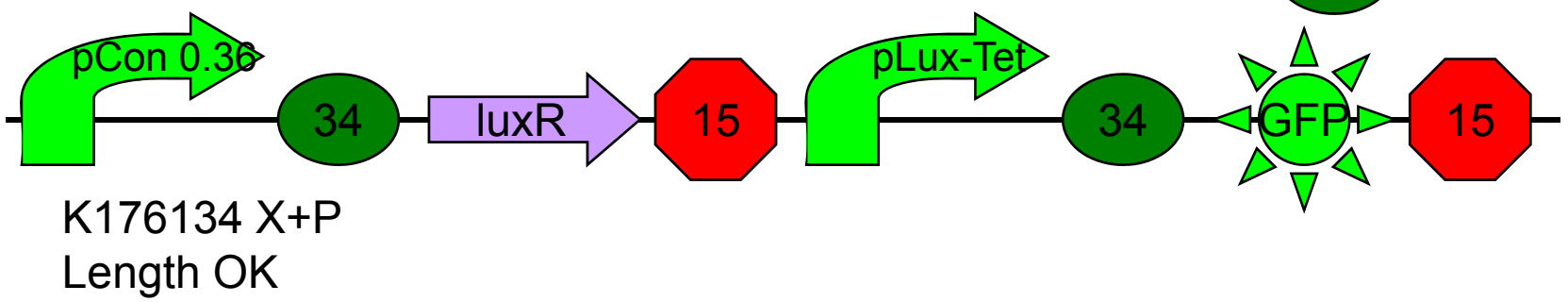
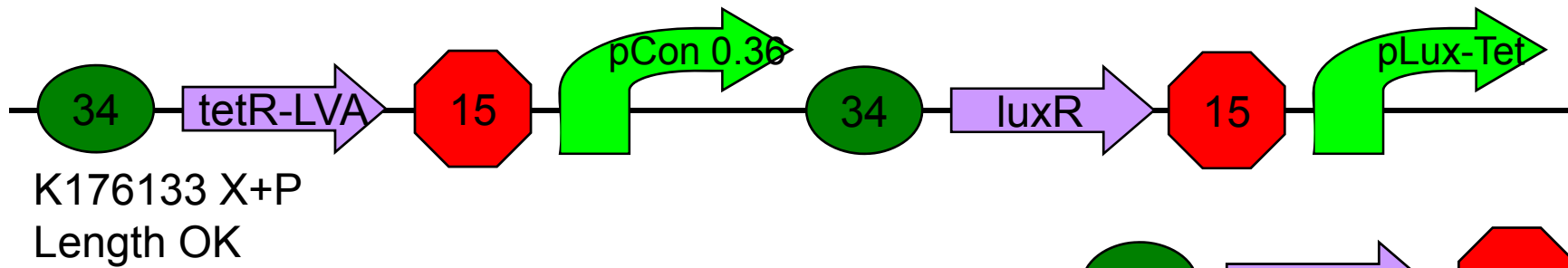

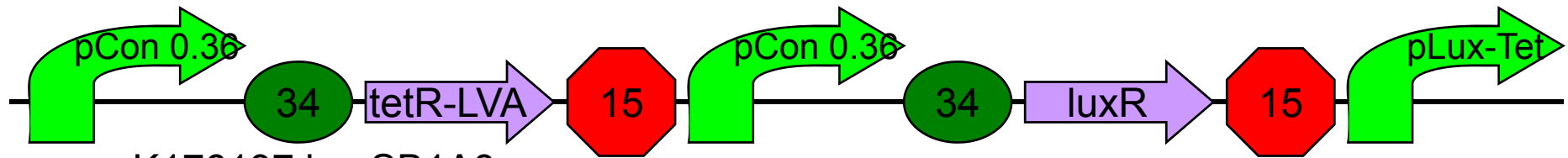

K176137 in pSB1A3  
Ligation

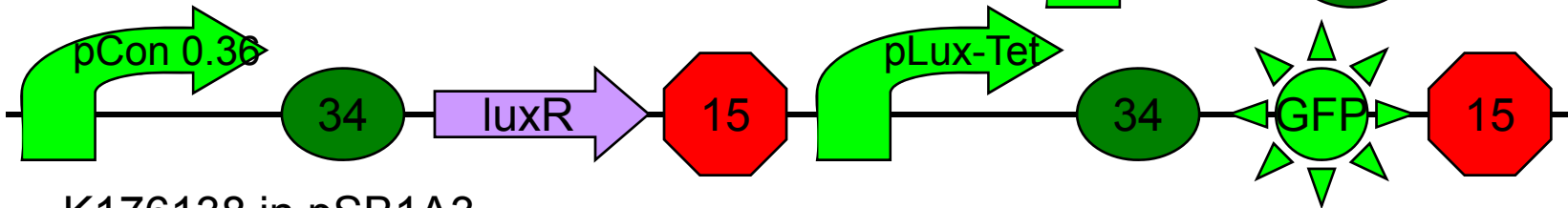
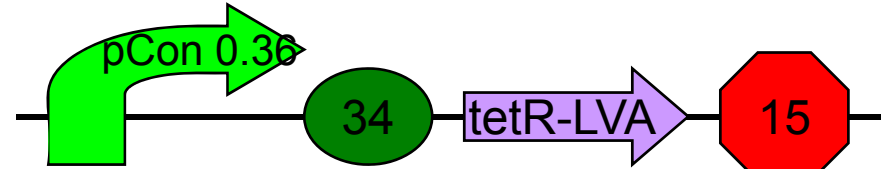

K176138 in pSB1A3  
Sequencing

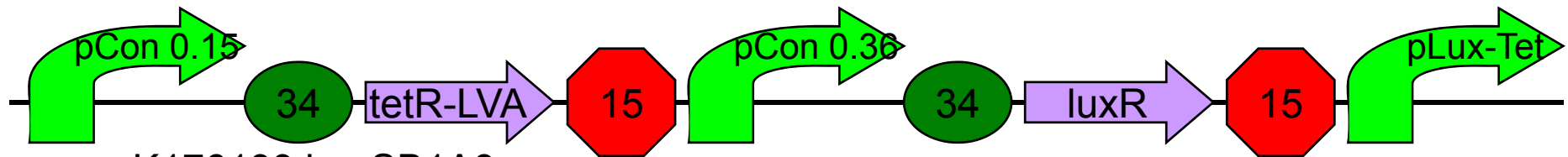

K176139 in pSB1A3  
Ligation

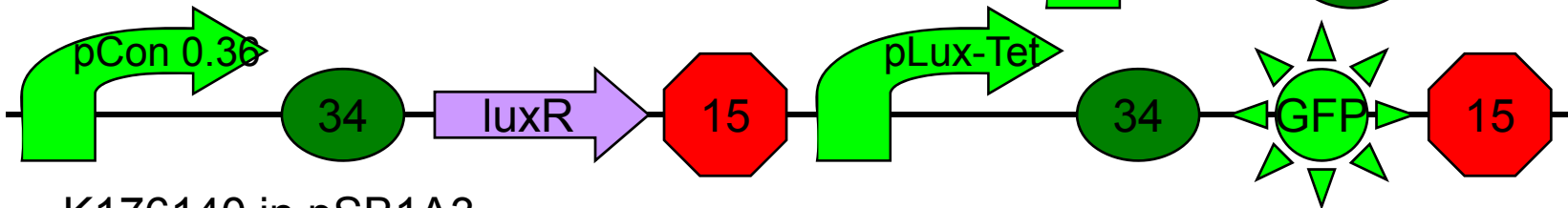
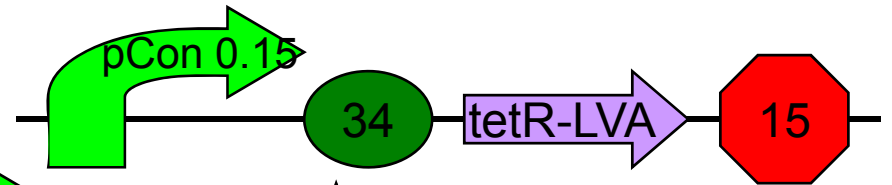

K176140 in pSB1A3  
Sequencing

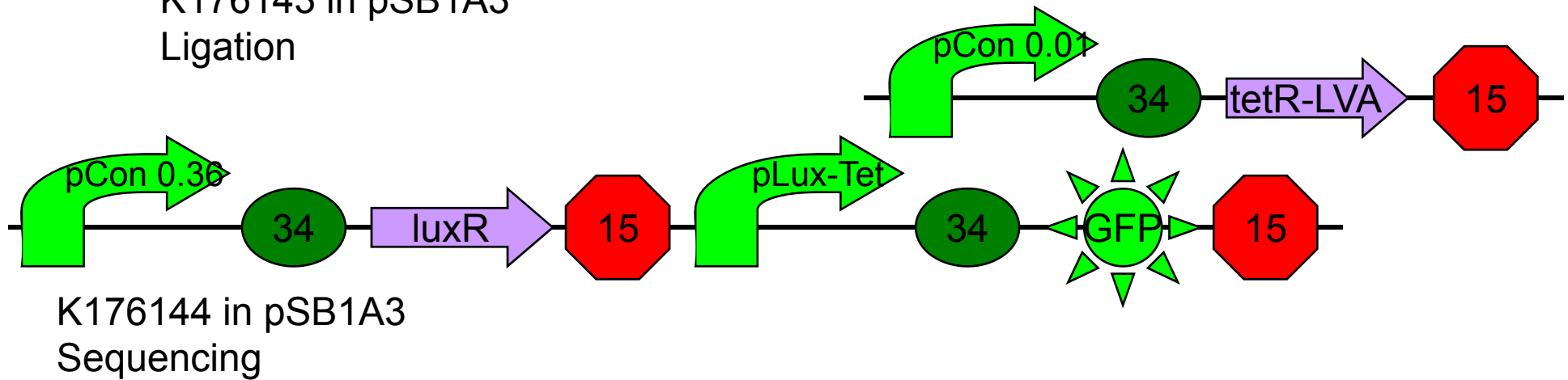
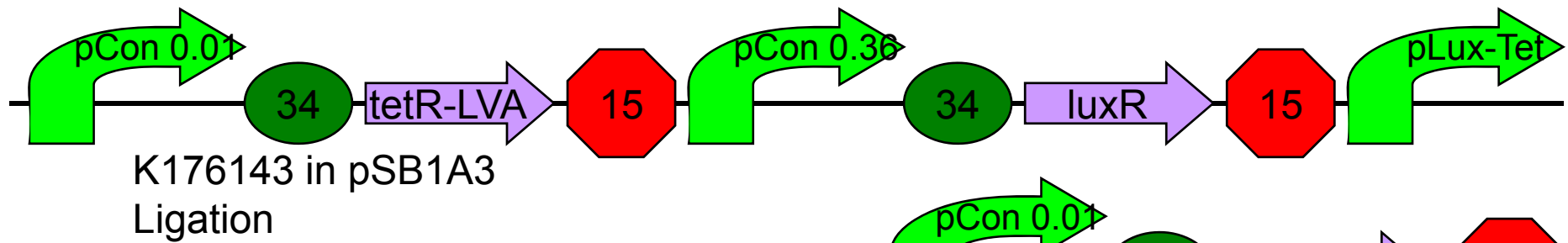
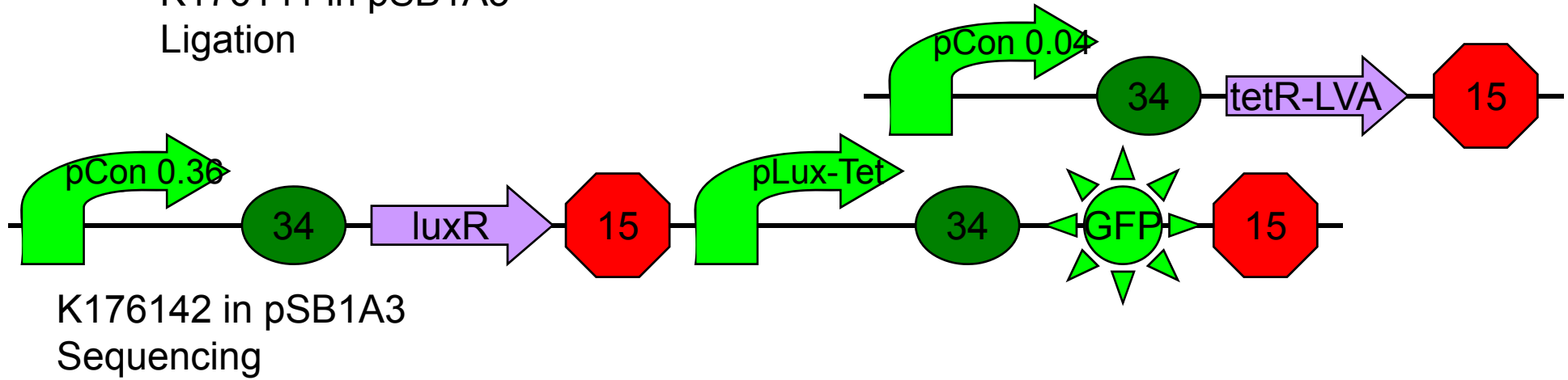
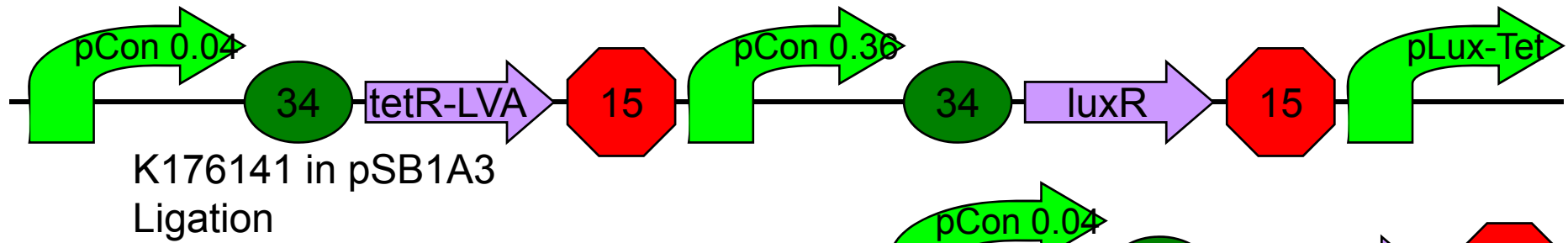

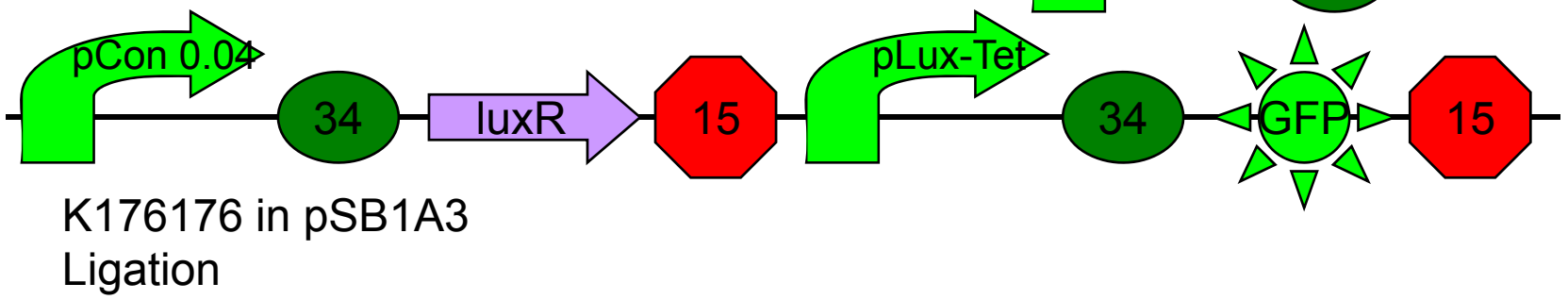
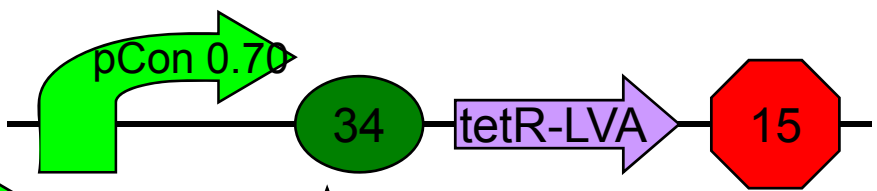
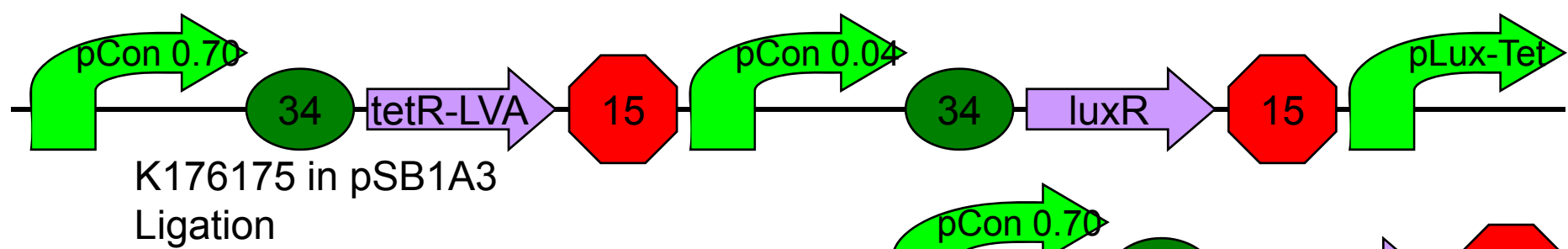
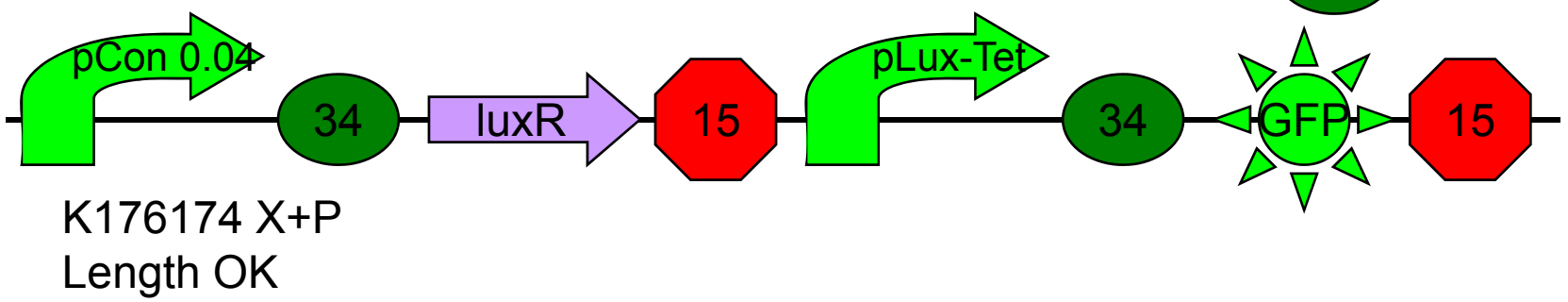
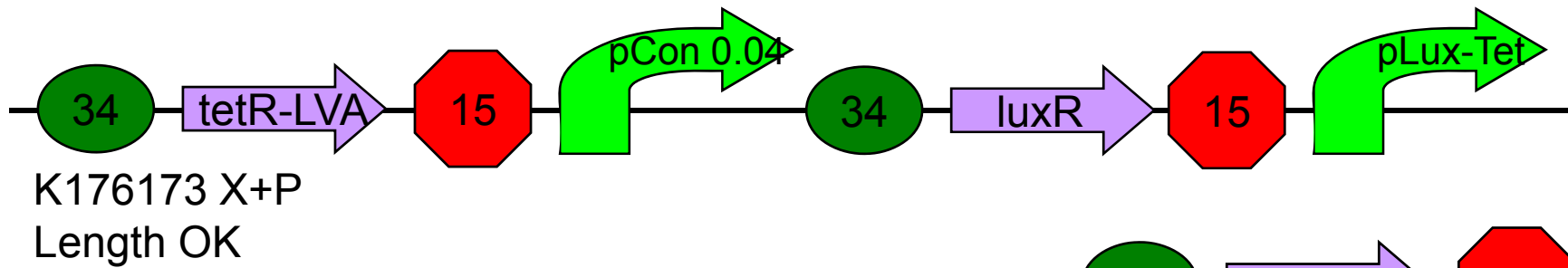

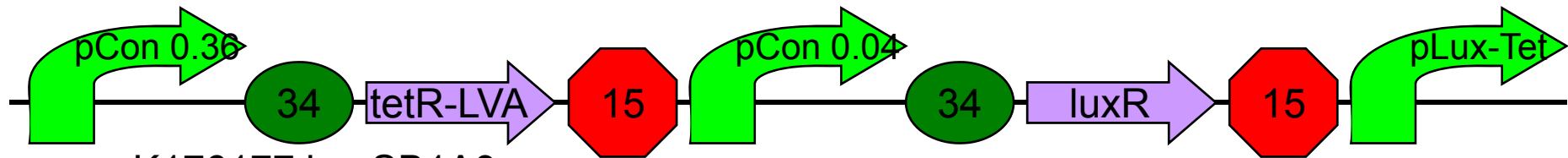

K176177 in pSB1A3  
Ligation

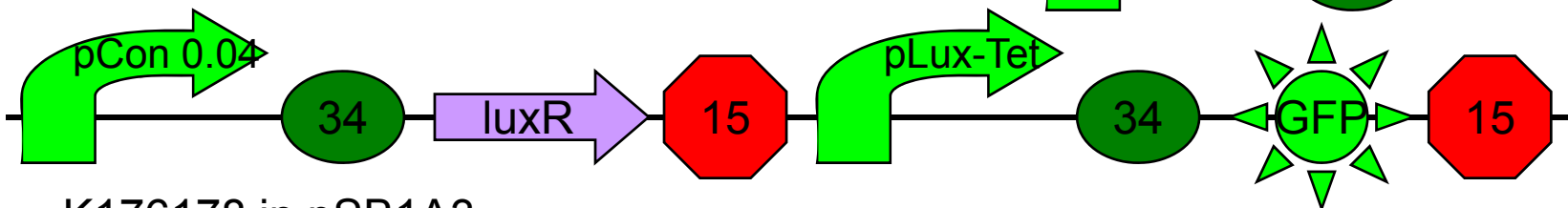
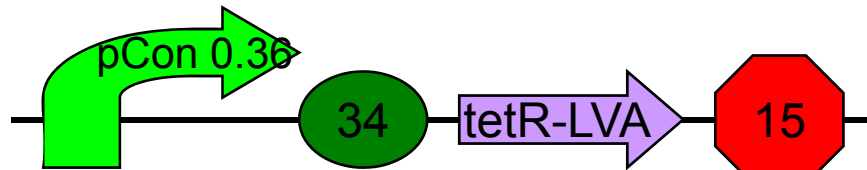

K176178 in pSB1A3  
Sequencing

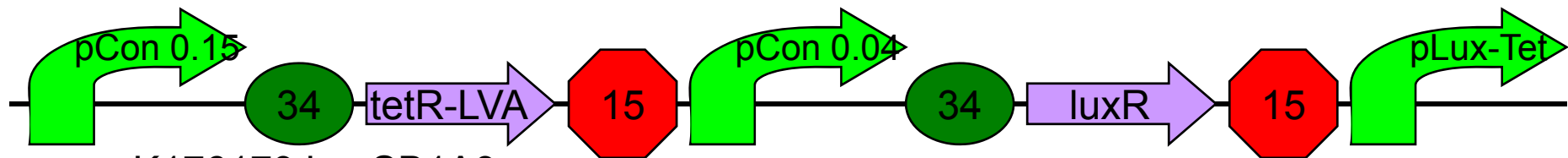

K176179 in pSB1A3  
Ligation

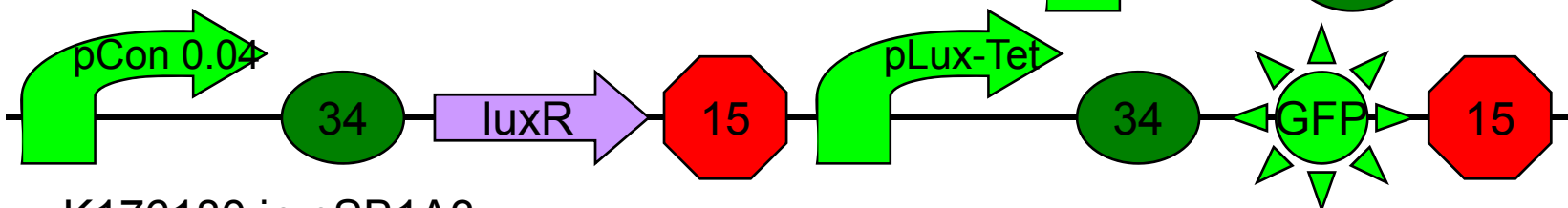
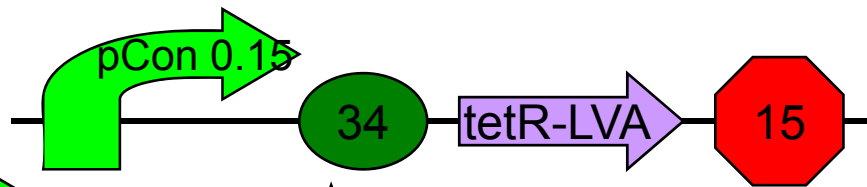

K176180 in pSB1A3  
Sequencing

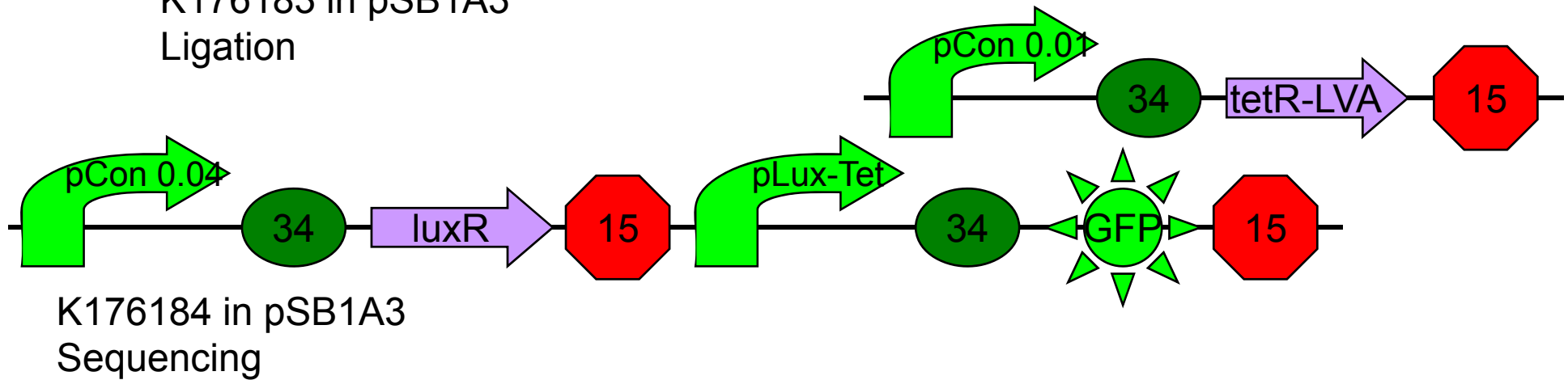
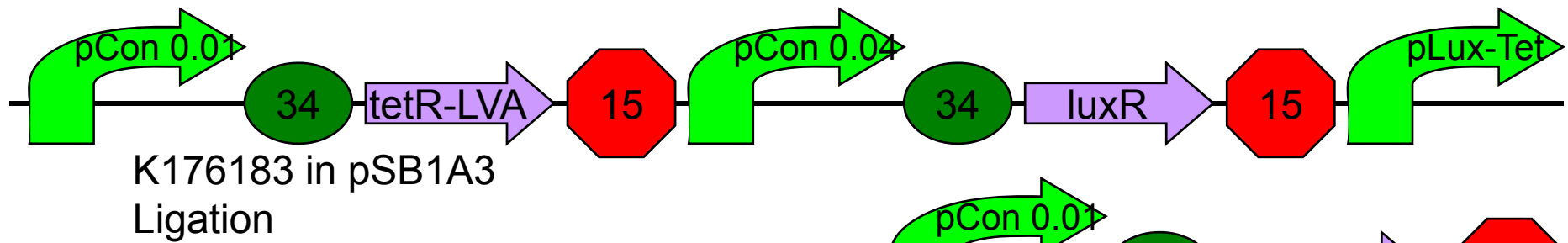
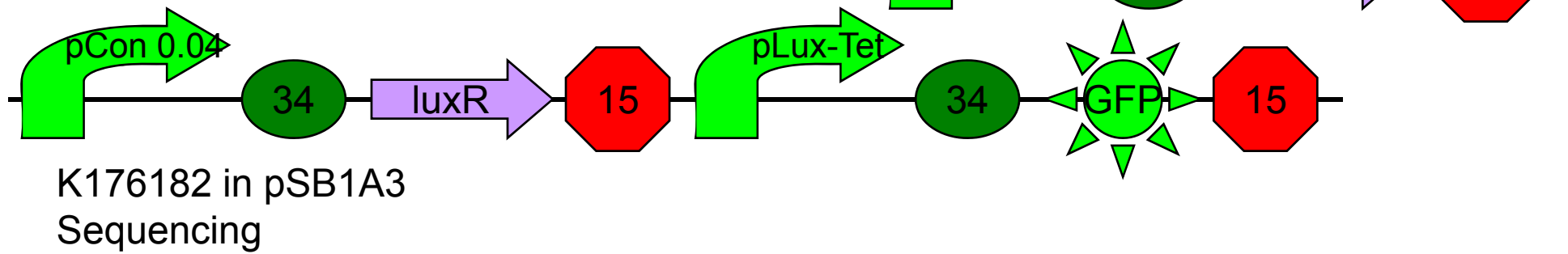
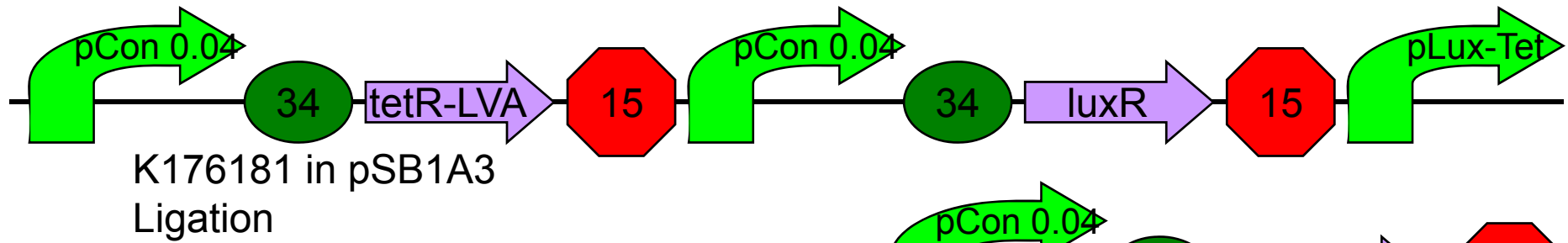

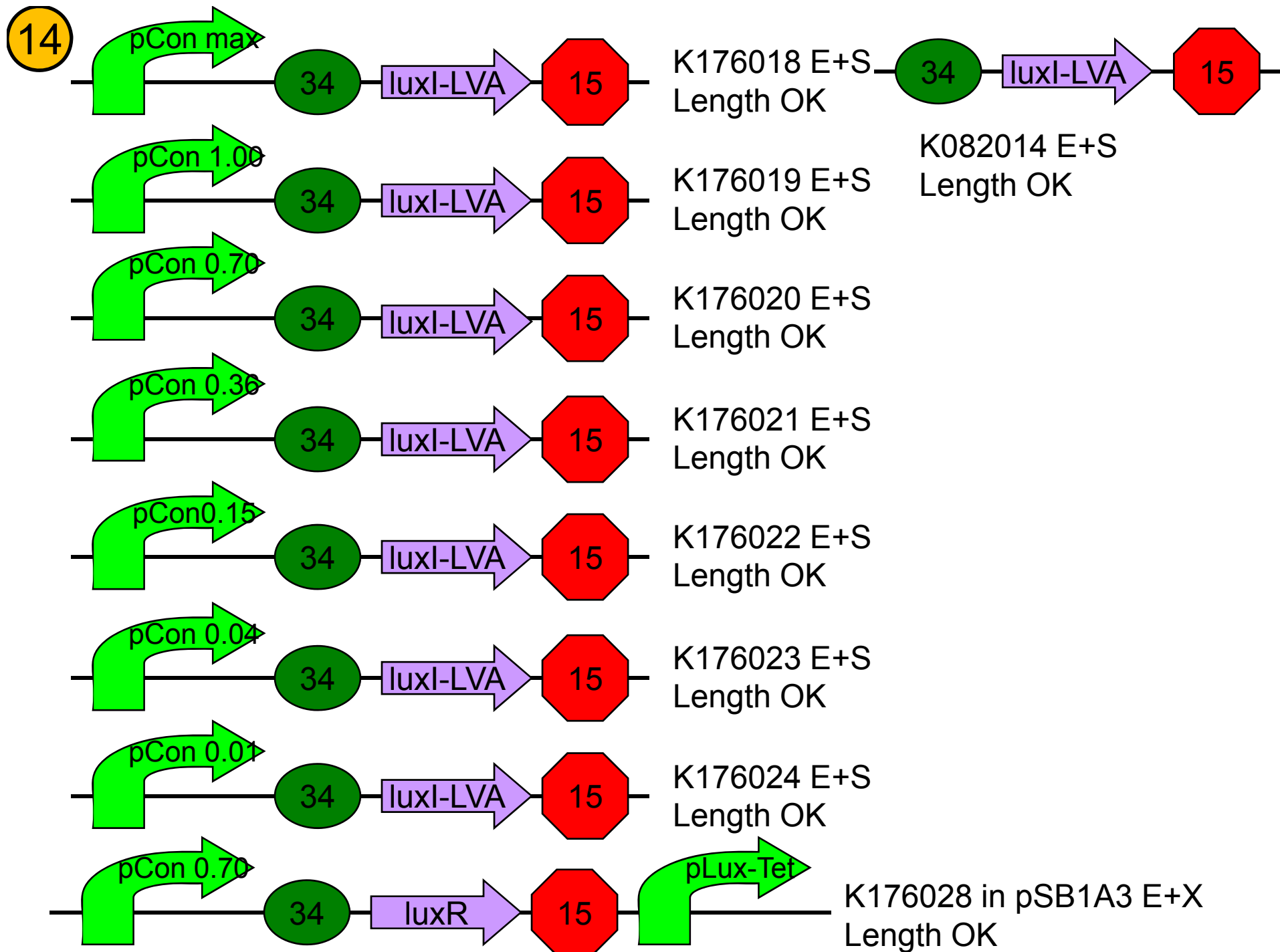

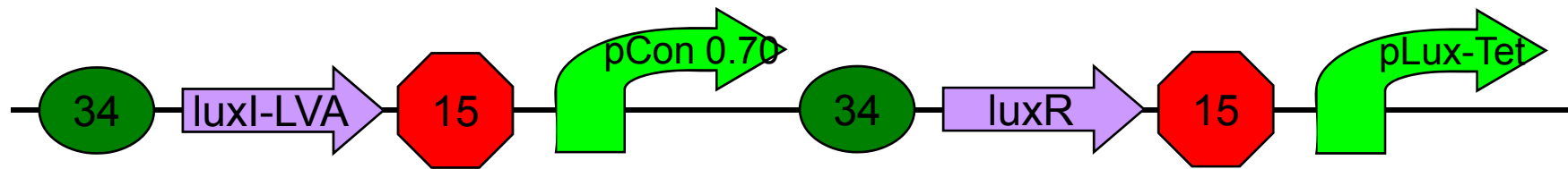

K176080 in pSB1A3  
Liagtion

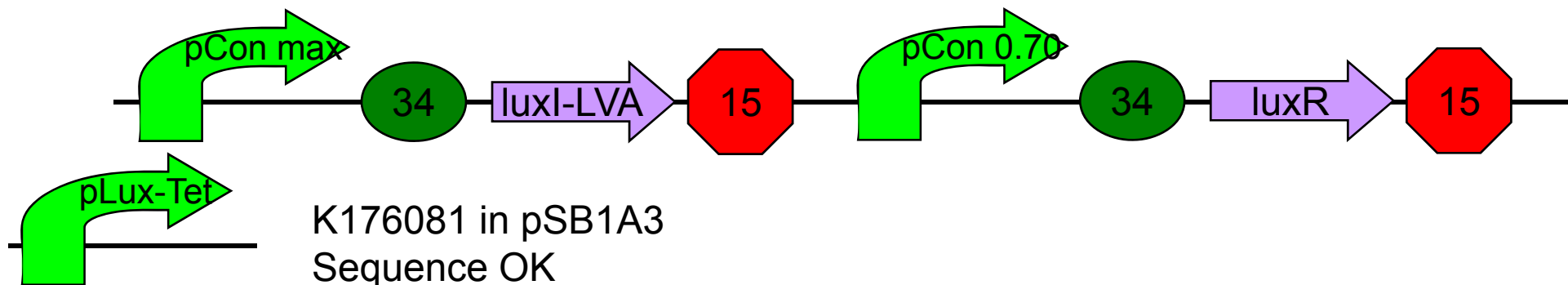

K176081 in pSB1A3  
Sequence OK

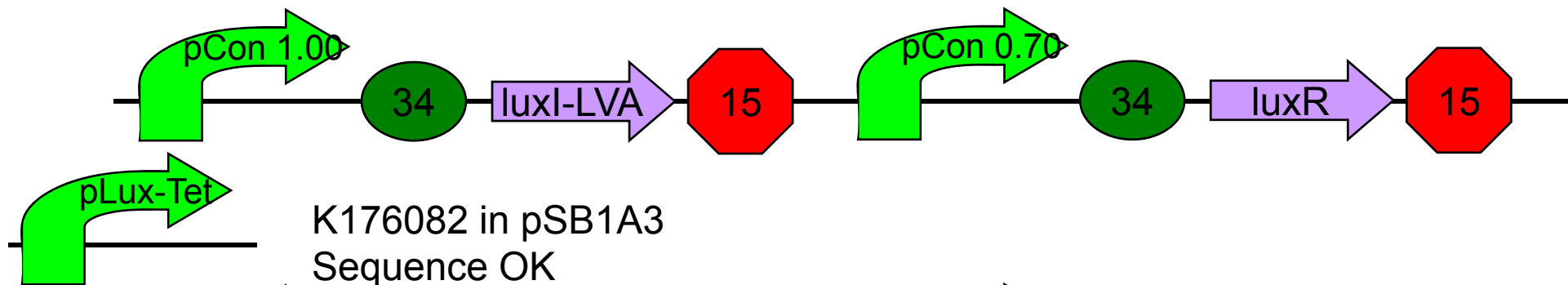

K176082 in pSB1A3  
Sequence OK

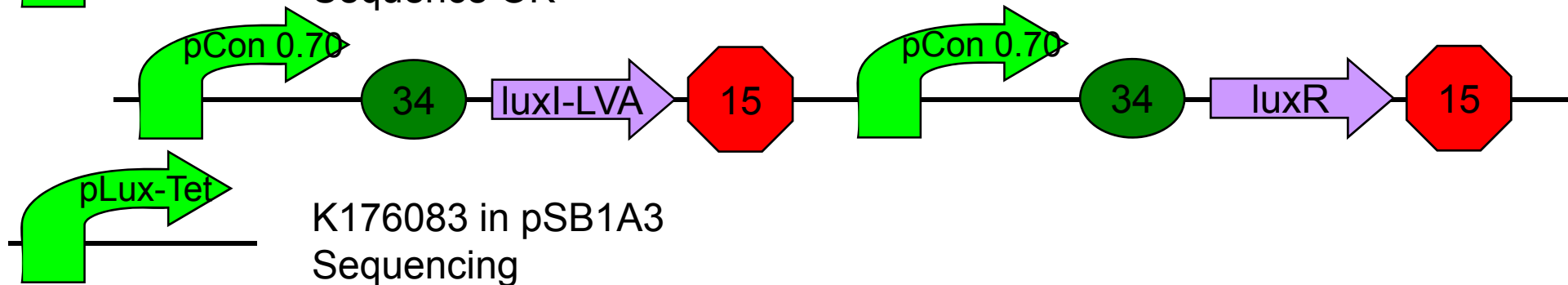

K176083 in pSB1A3  
Sequencing



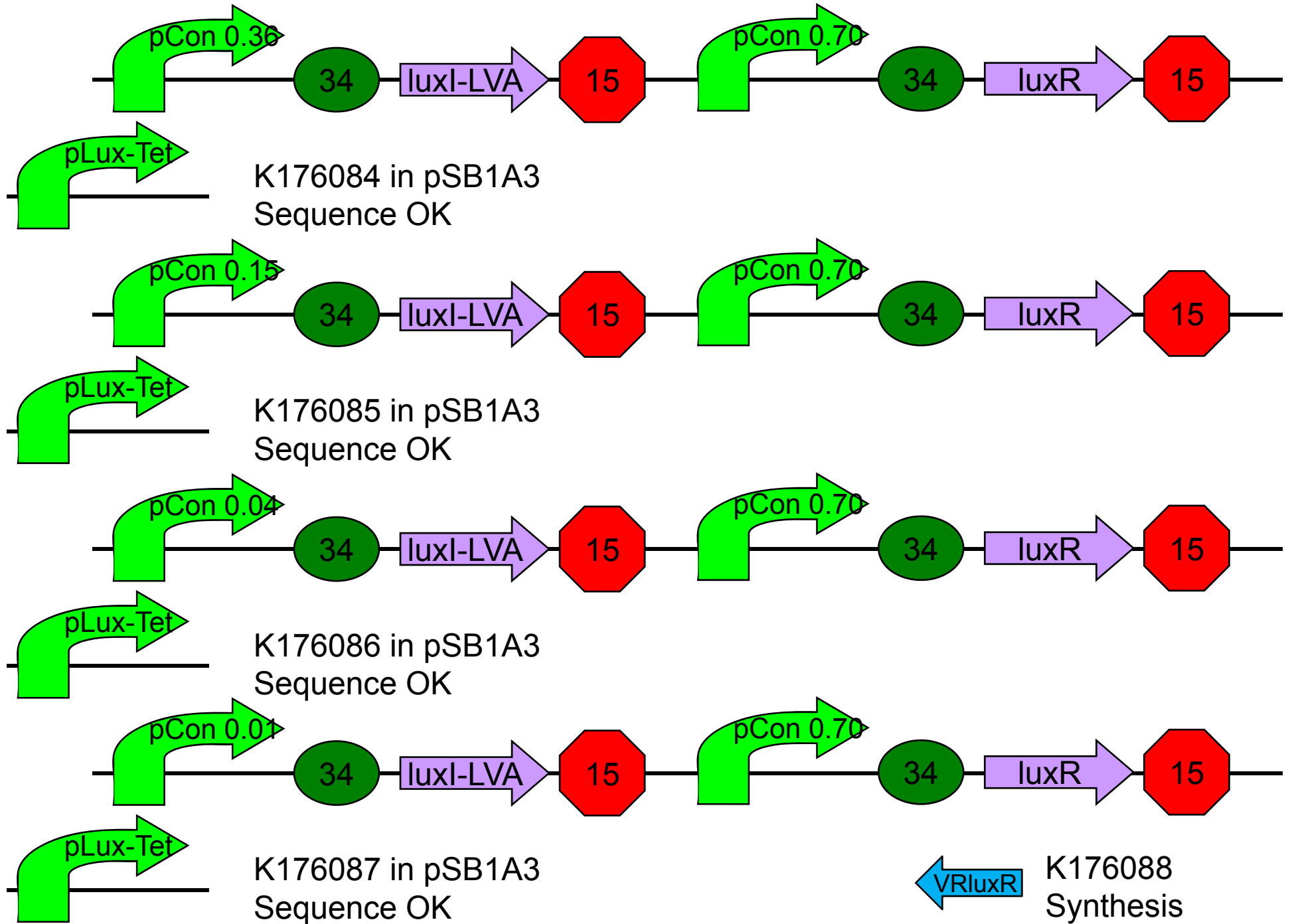

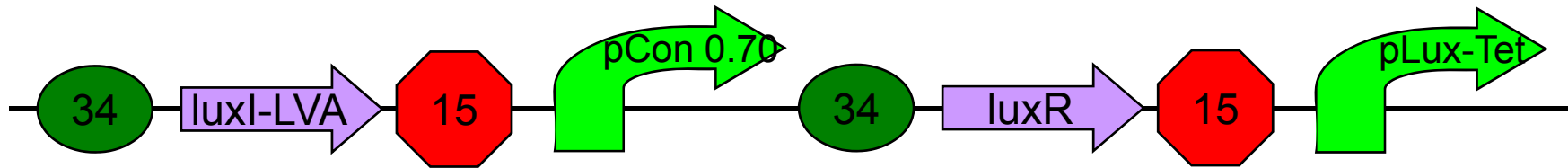

K176080 in pSB1A3 S+P  
Waiting

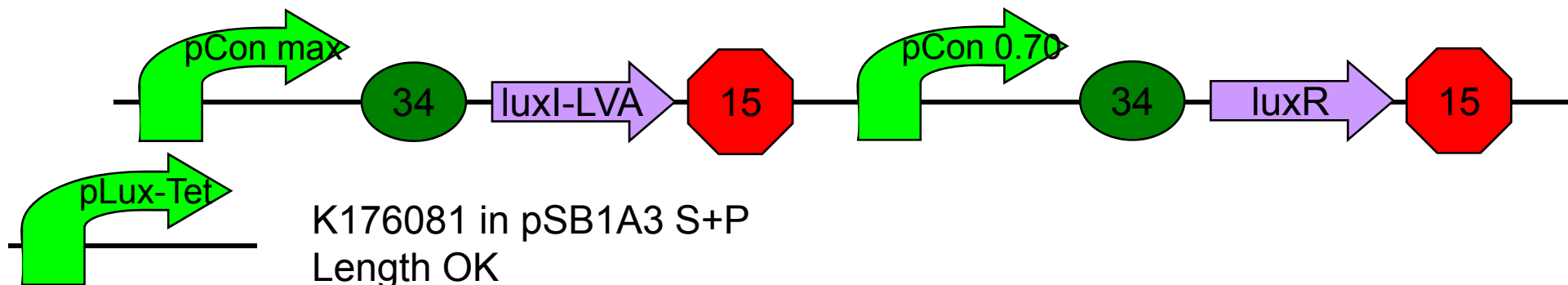

K176081 in pSB1A3 S+P  
Length OK

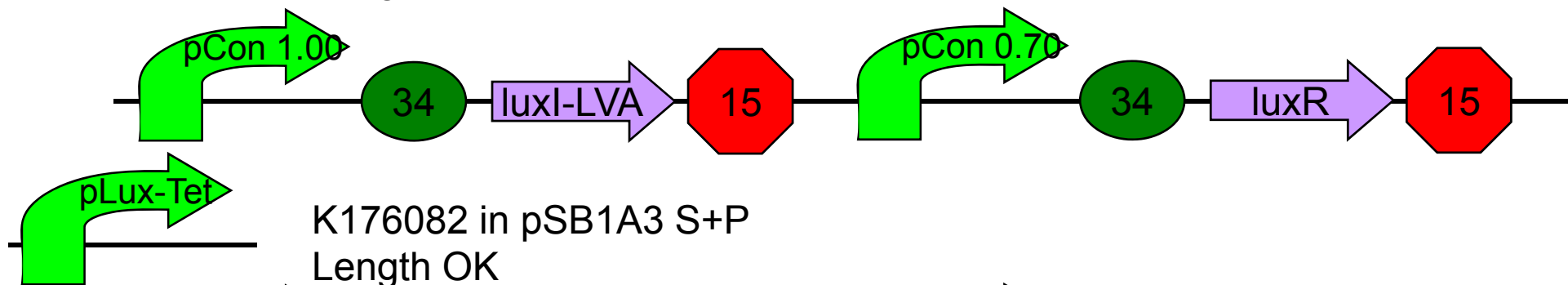

K176082 in pSB1A3 S+P  
Length OK

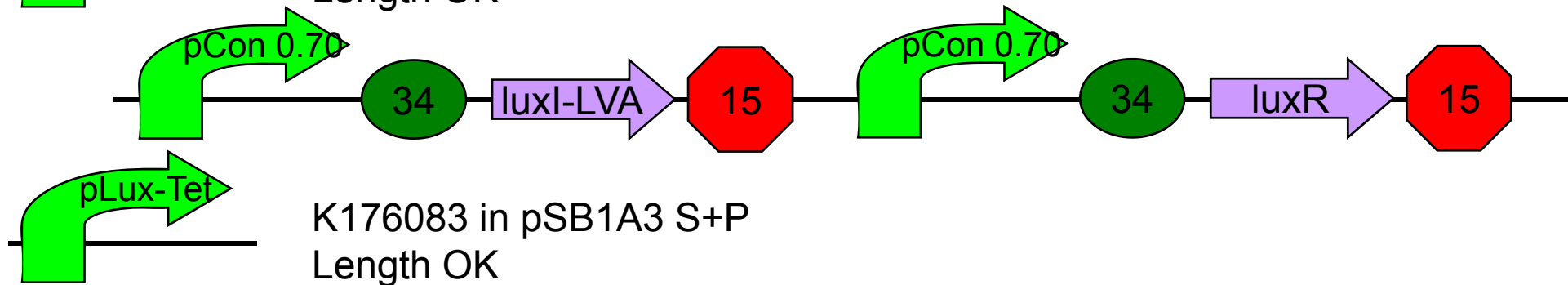

K176083 in pSB1A3 S+P  
Length OK

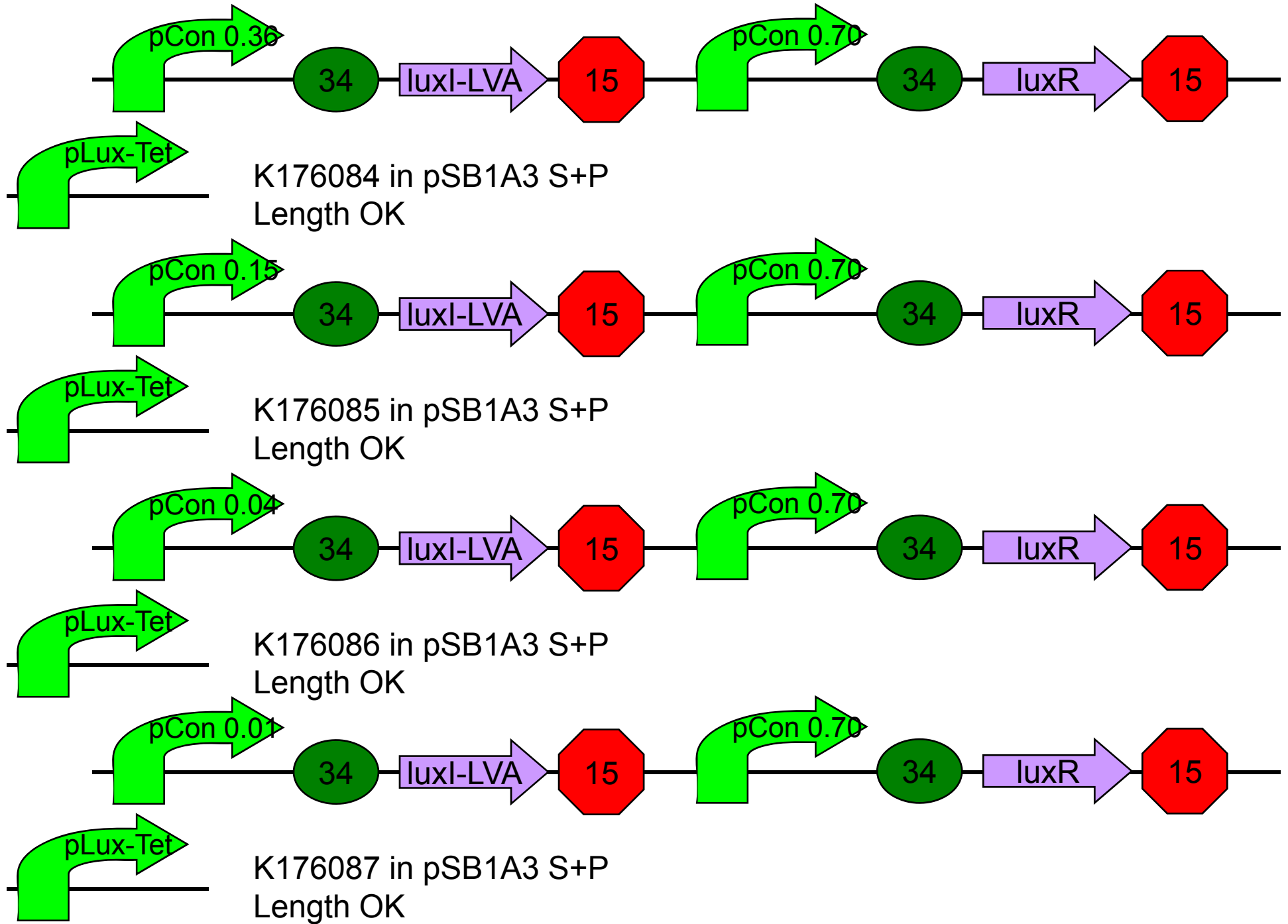

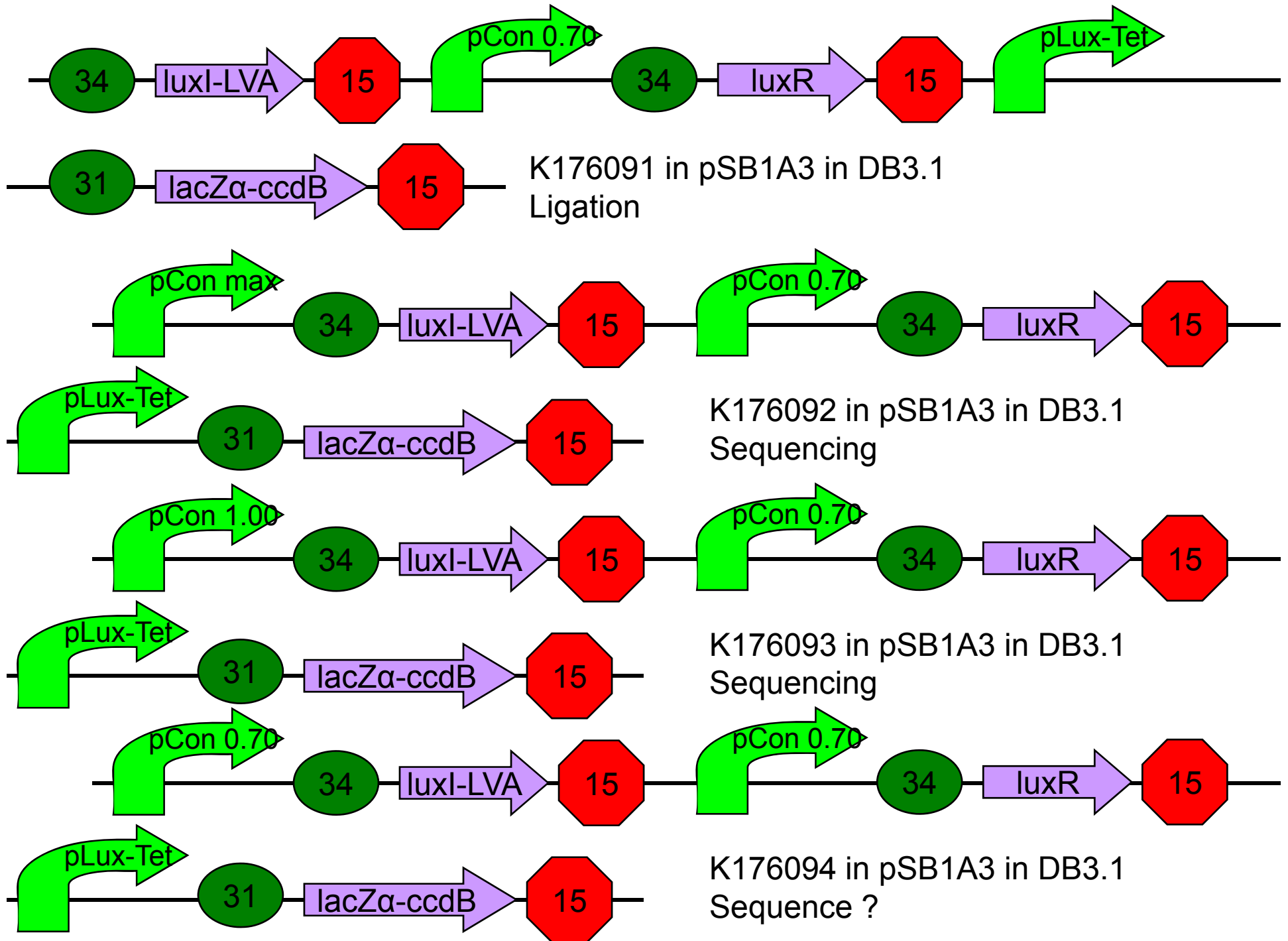

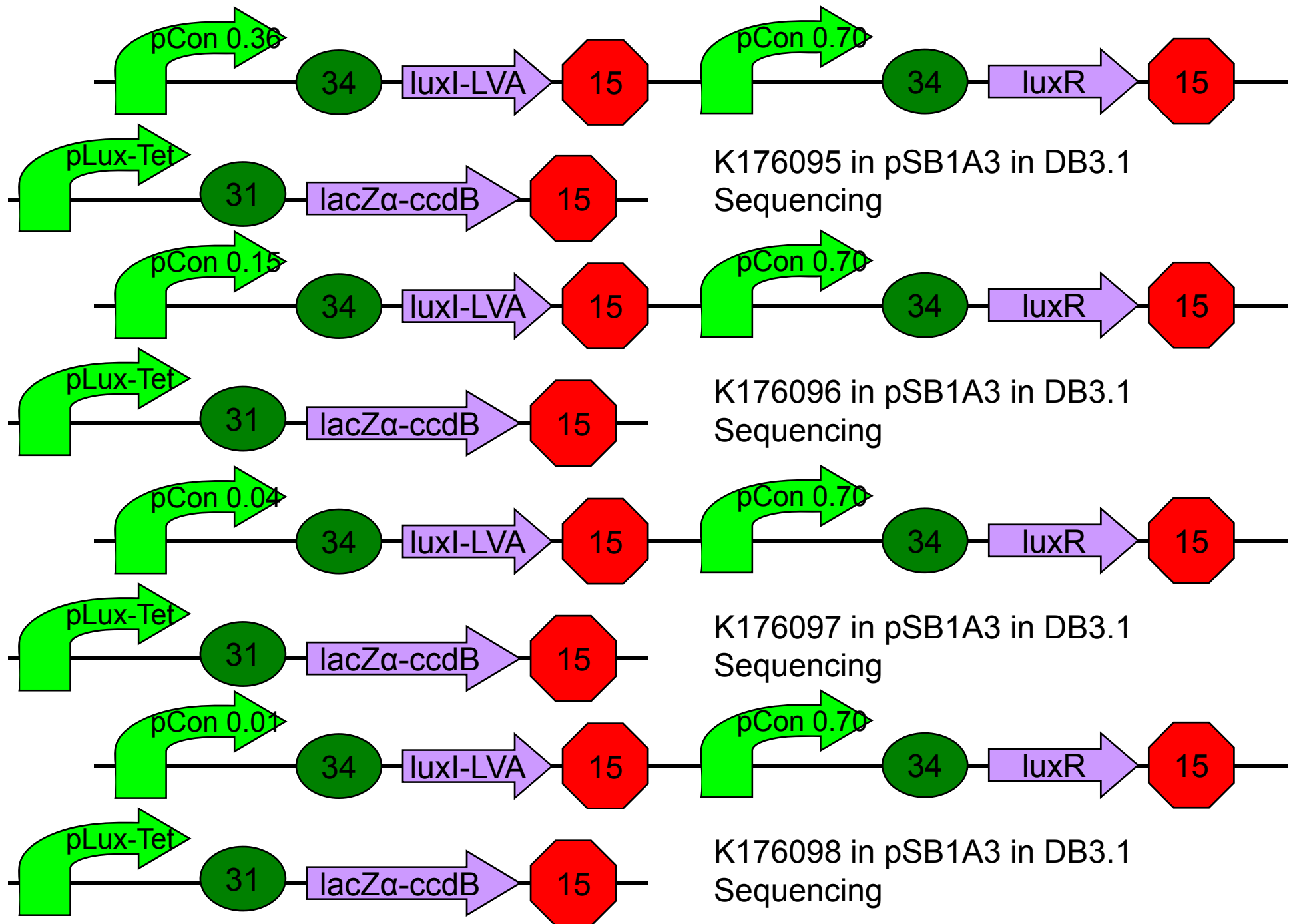

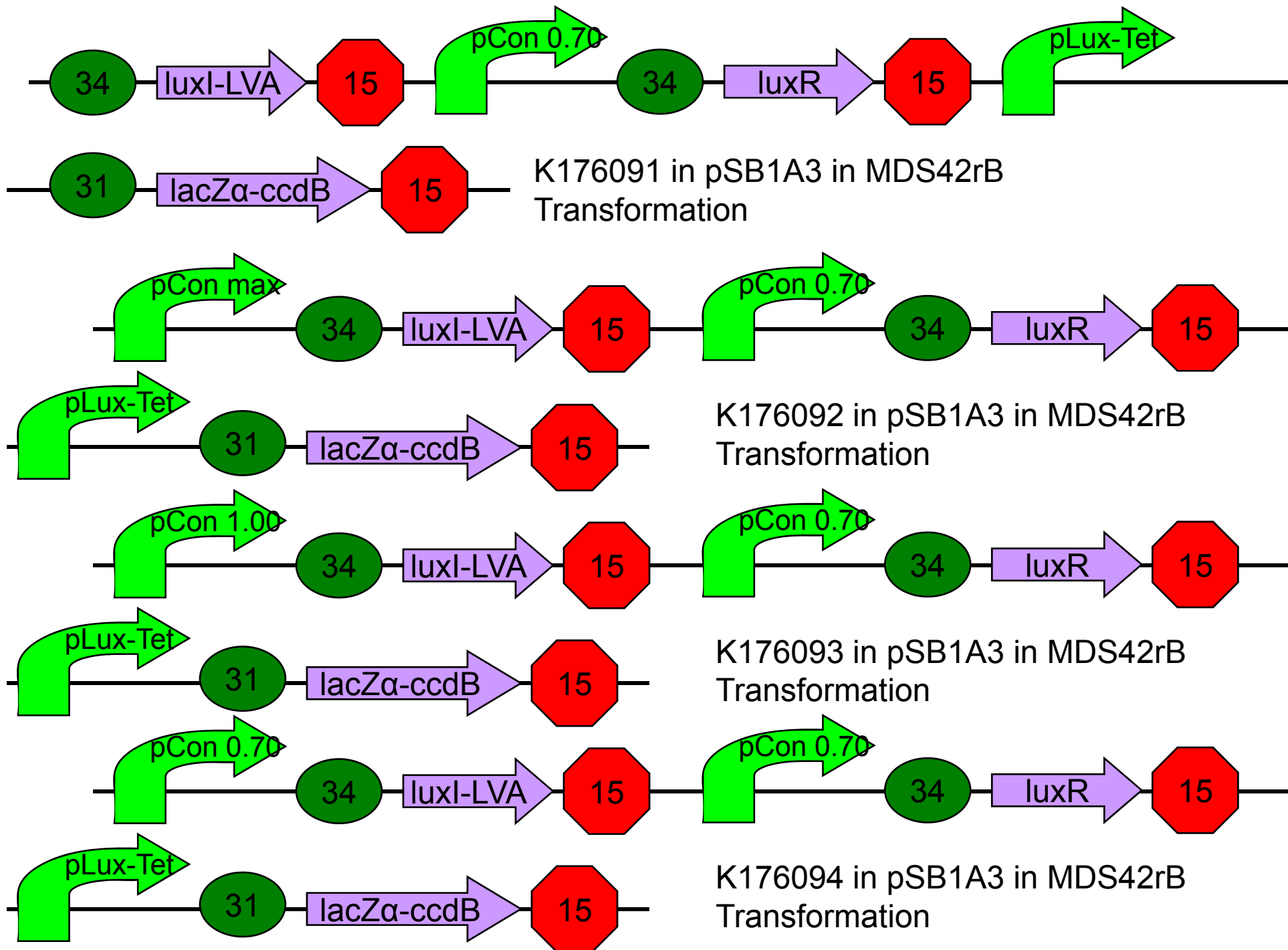

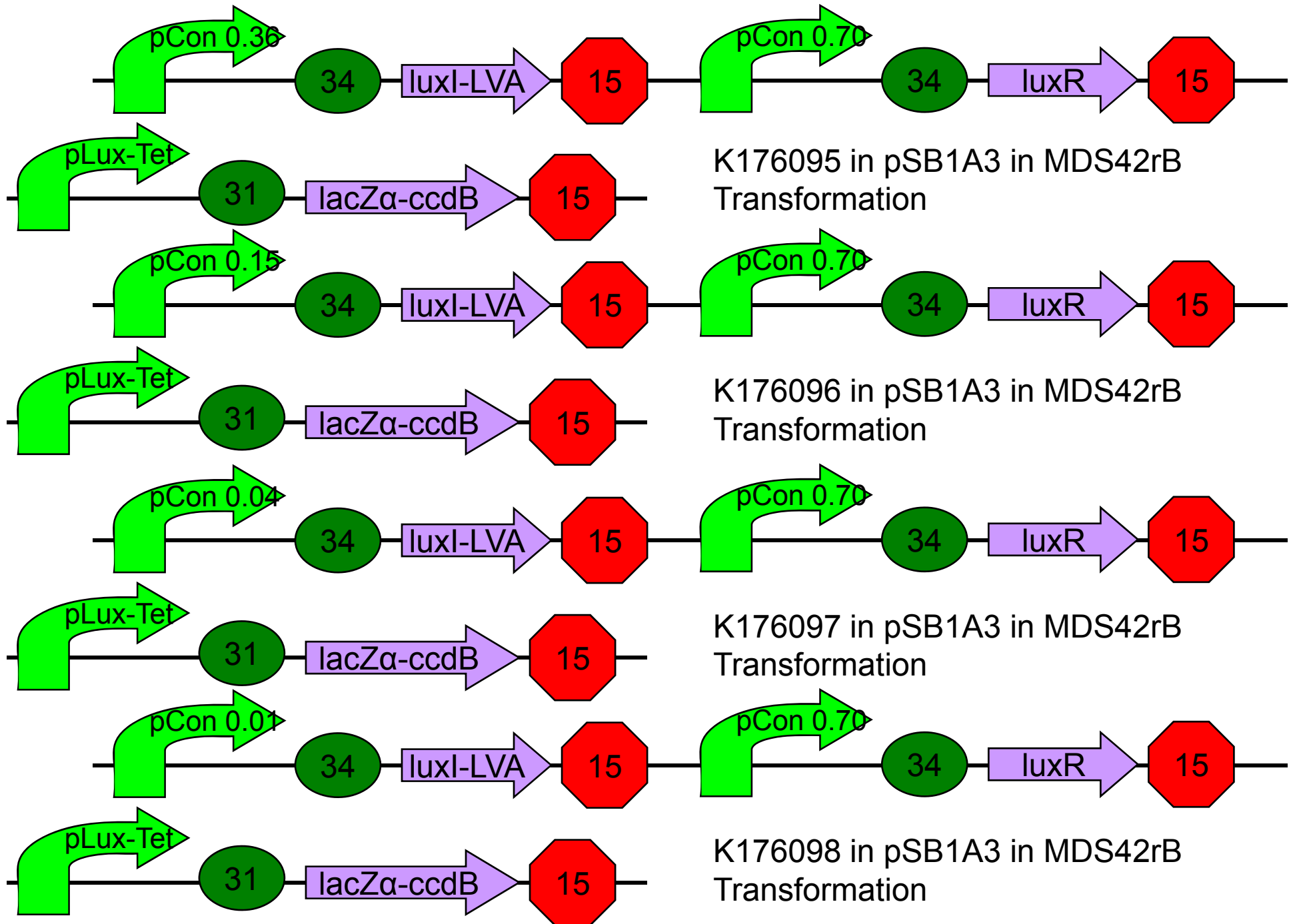

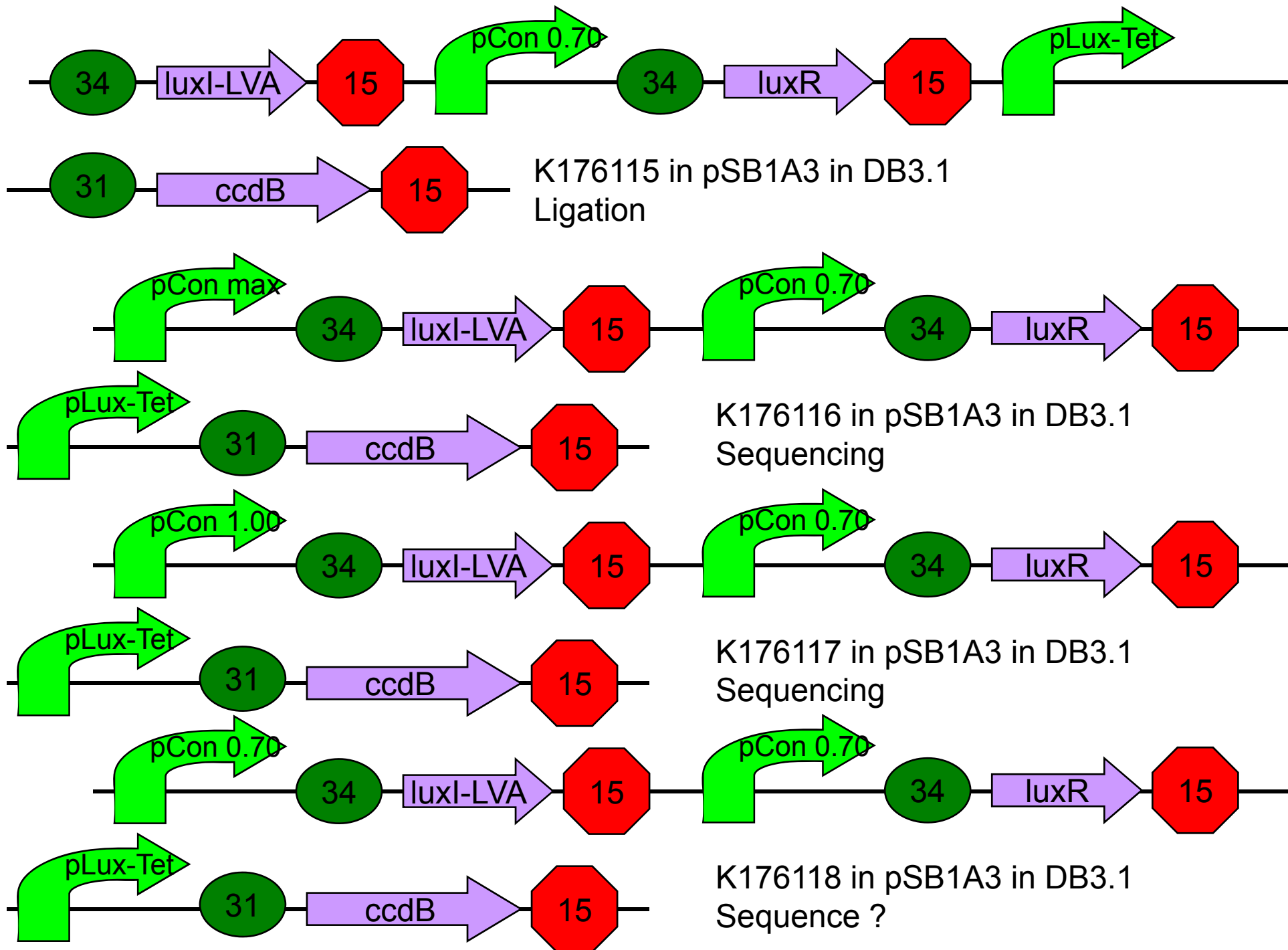



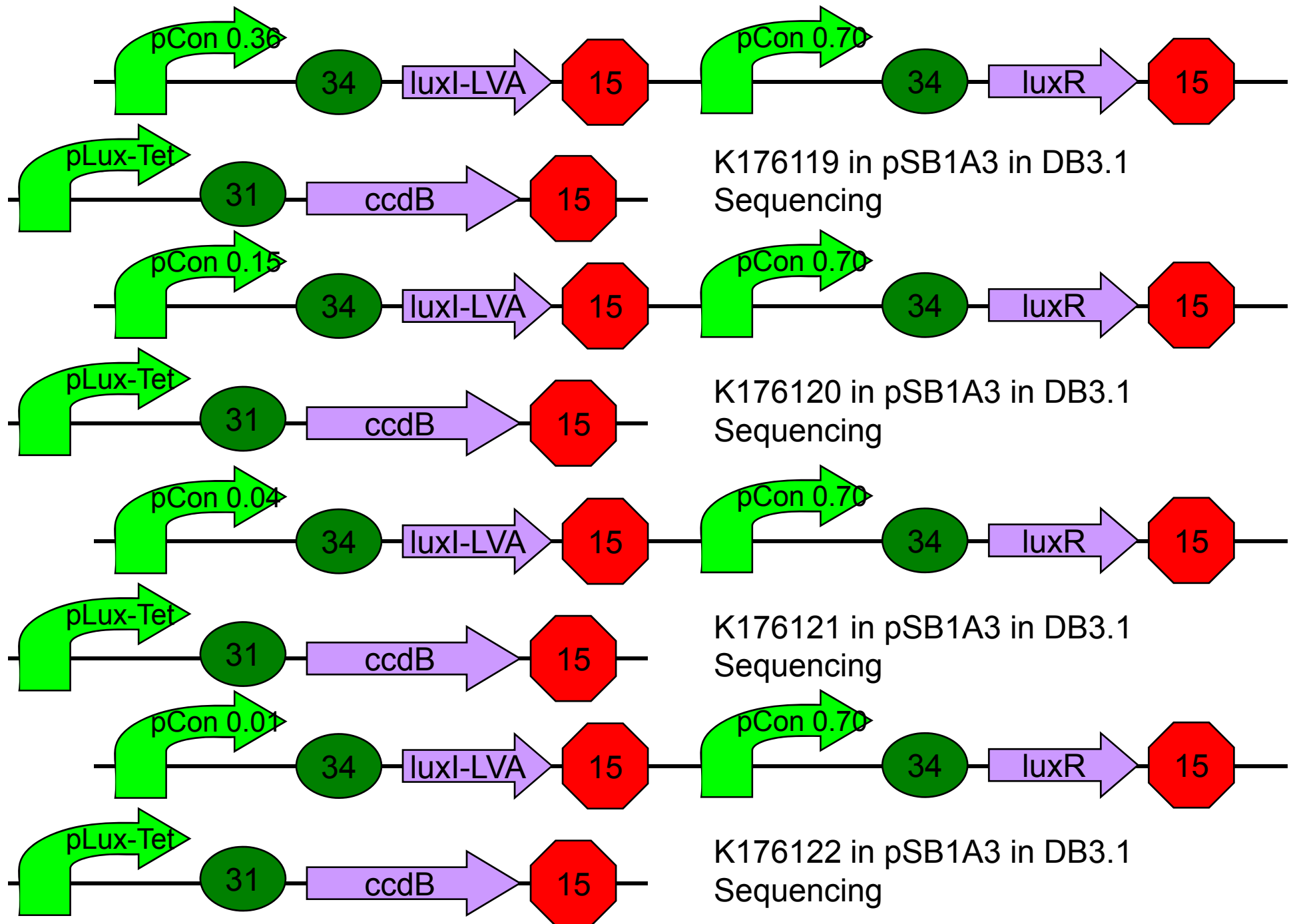

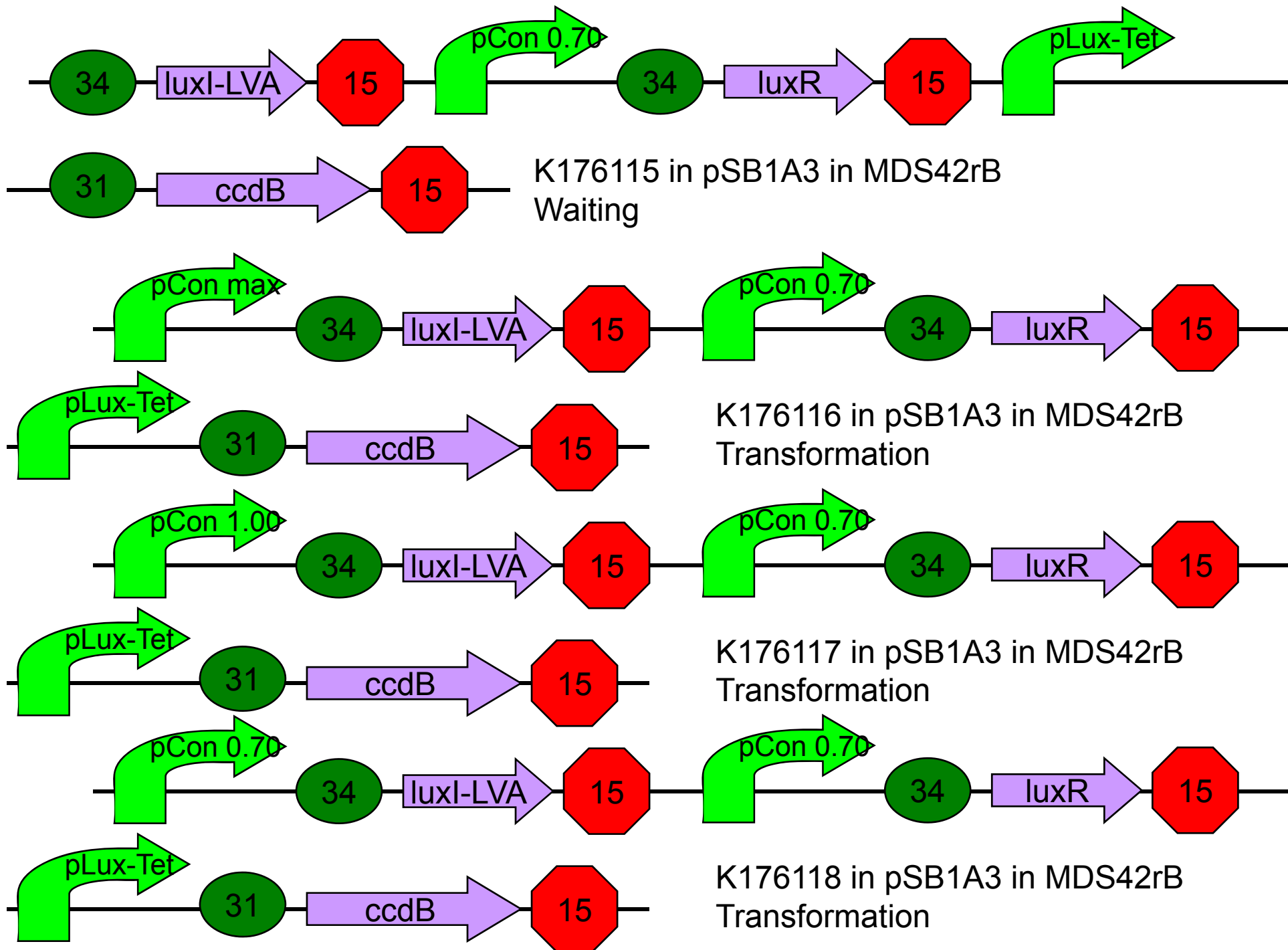

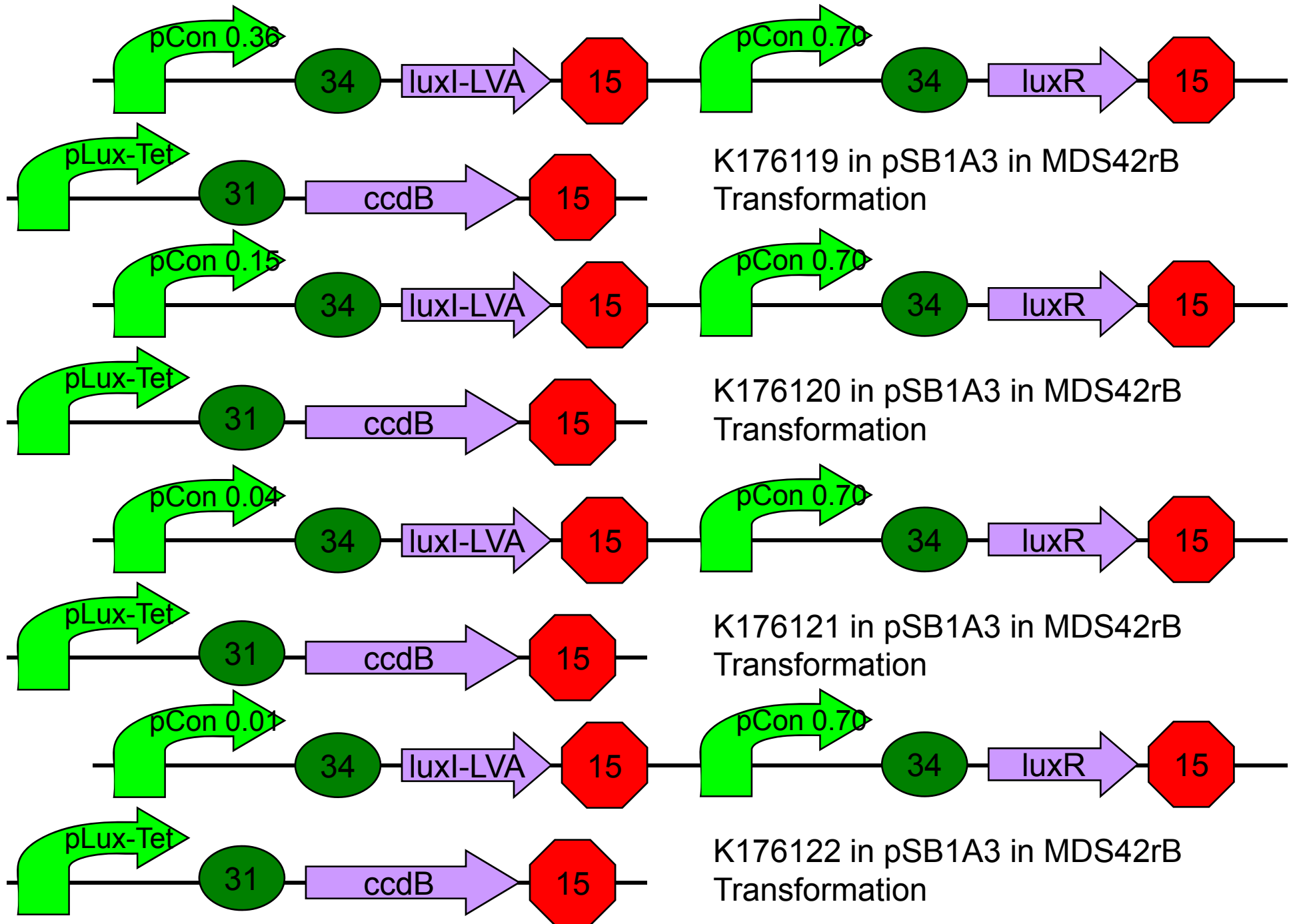

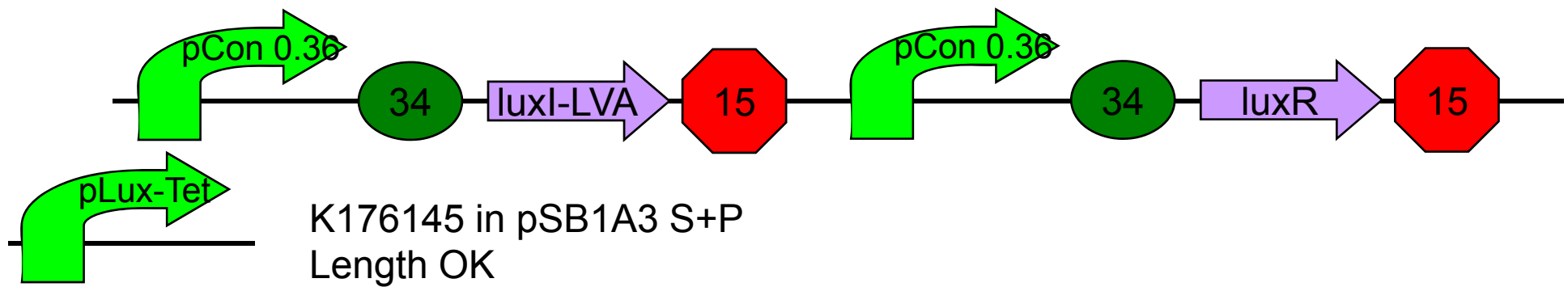
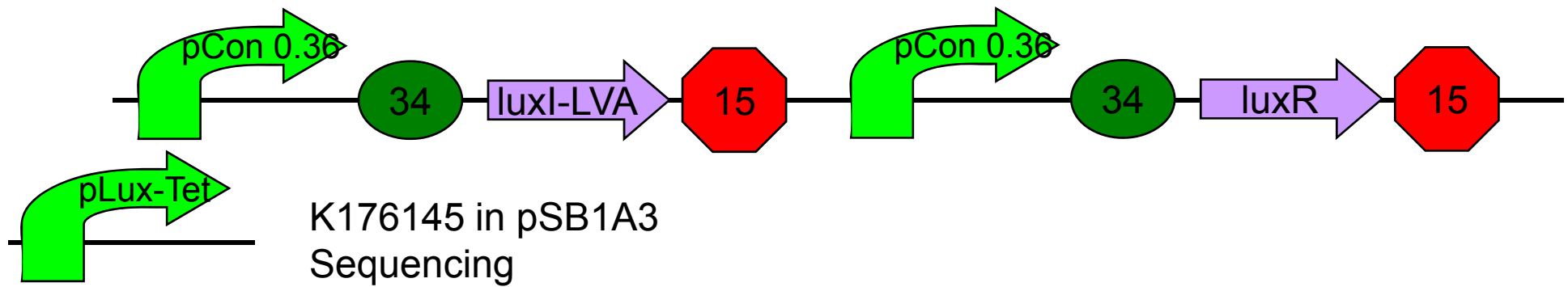
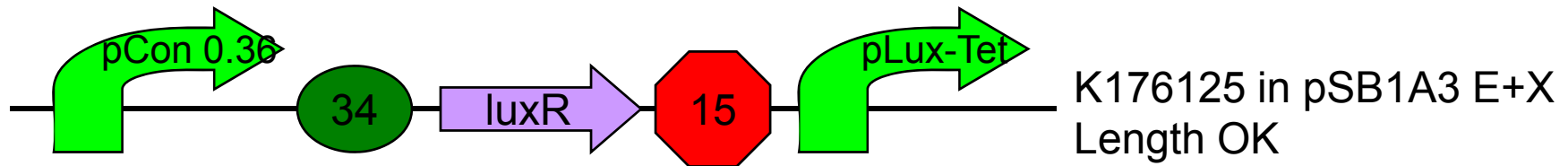

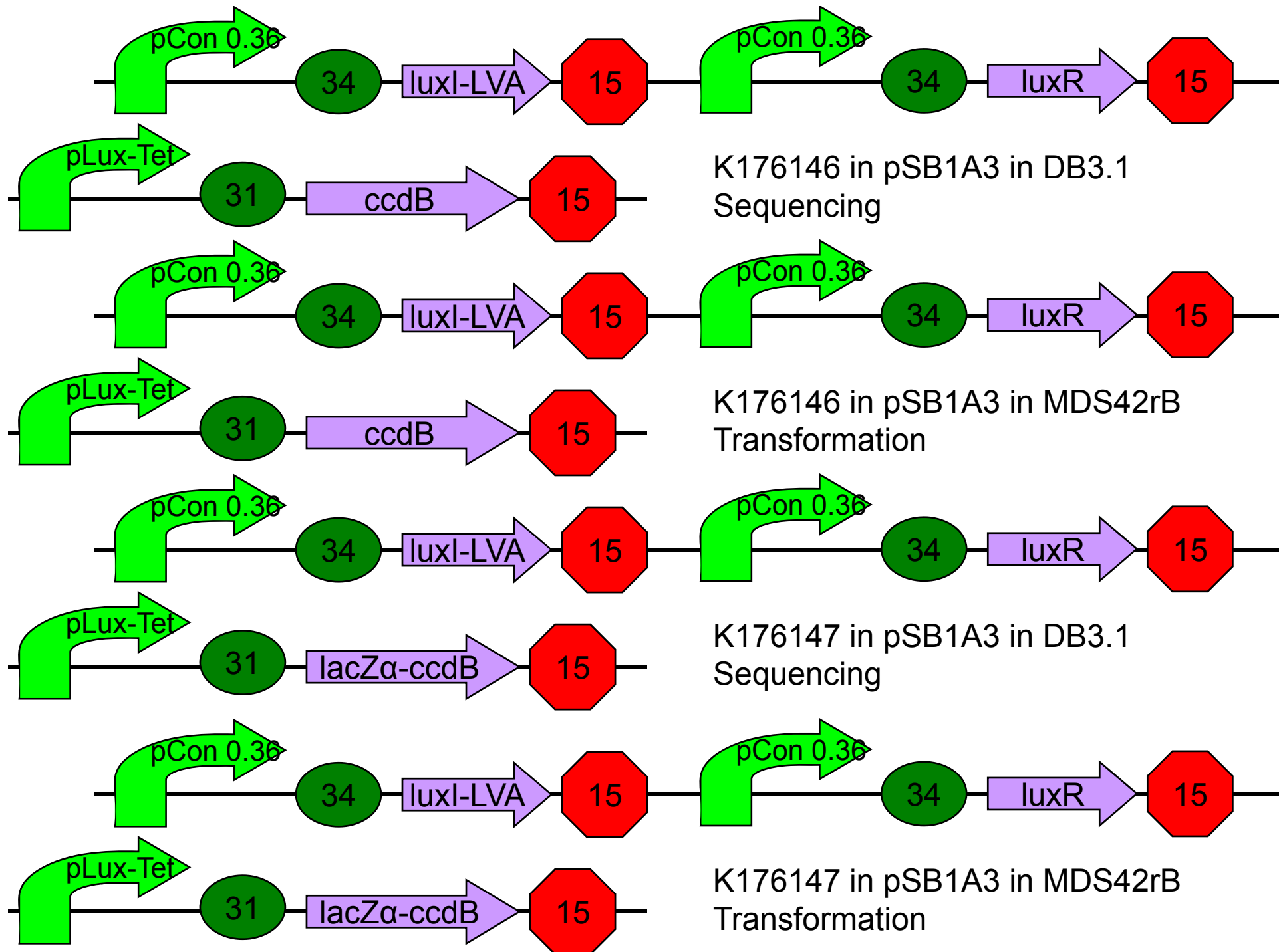

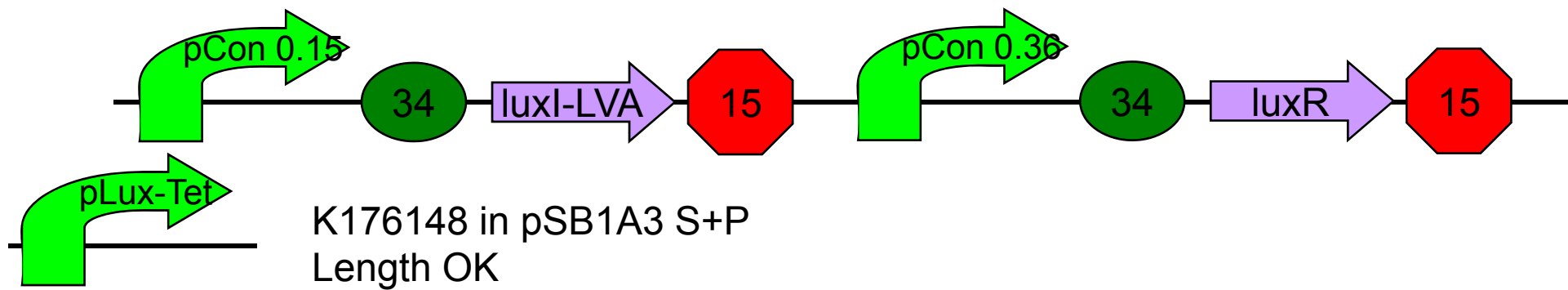
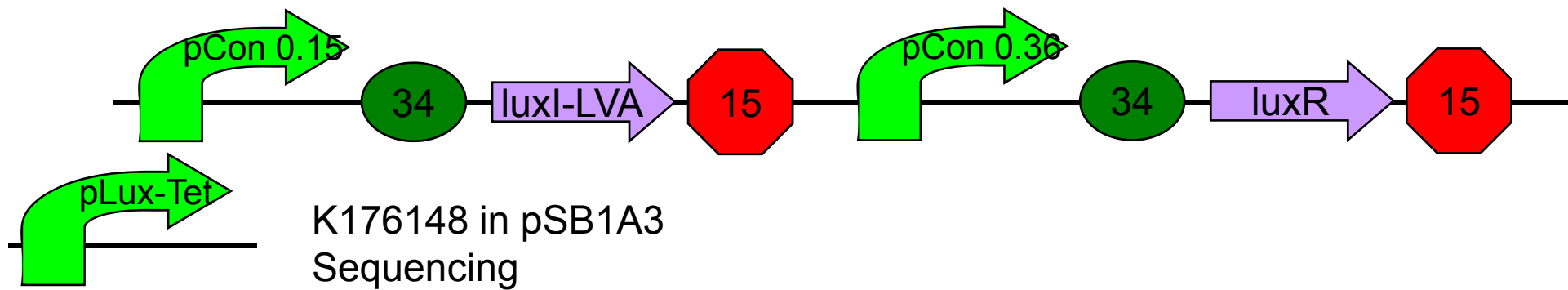

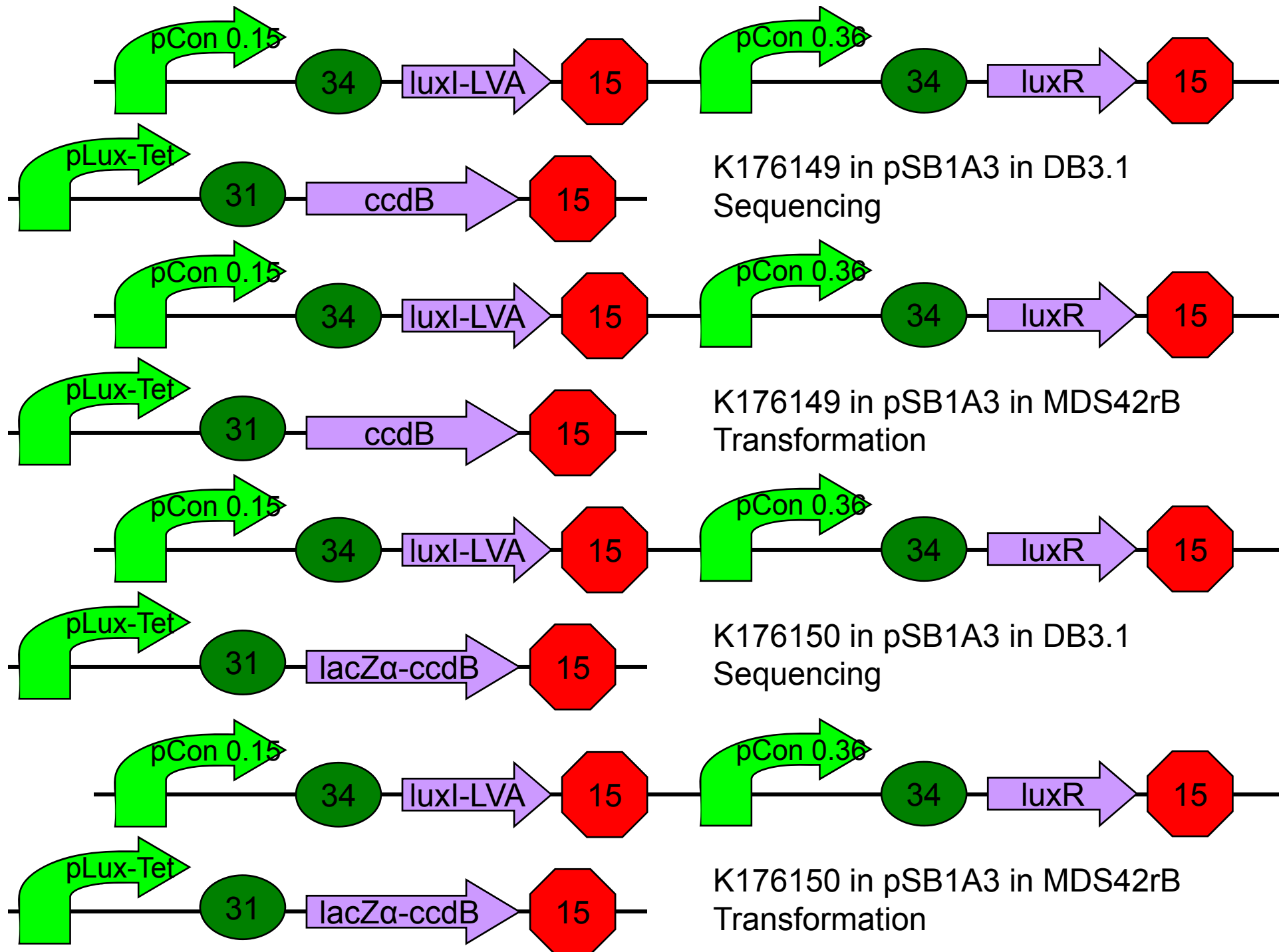

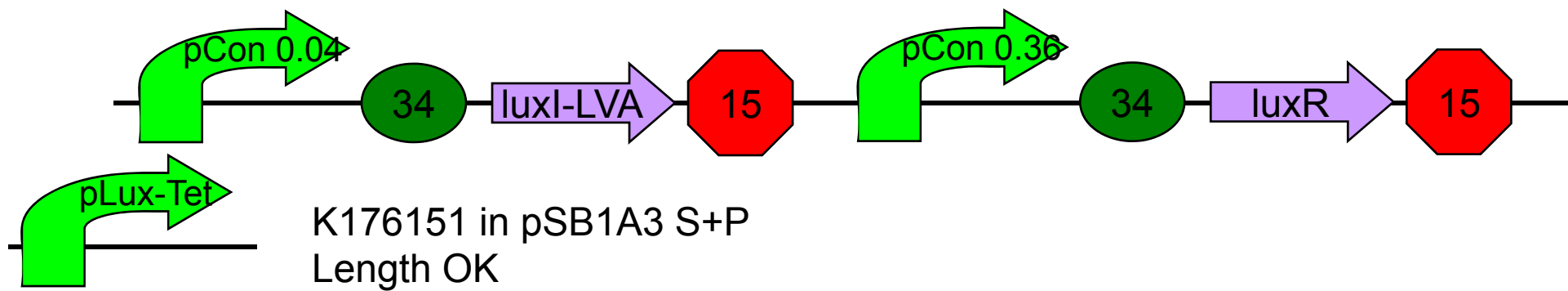
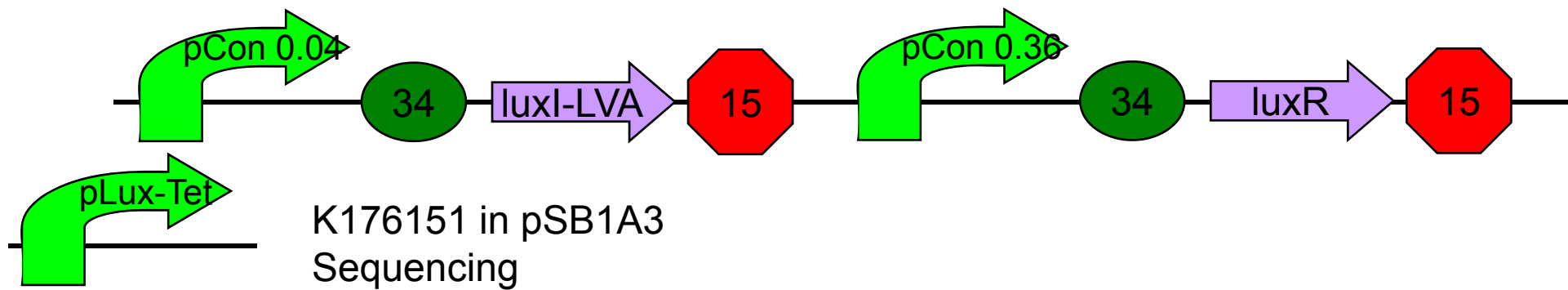



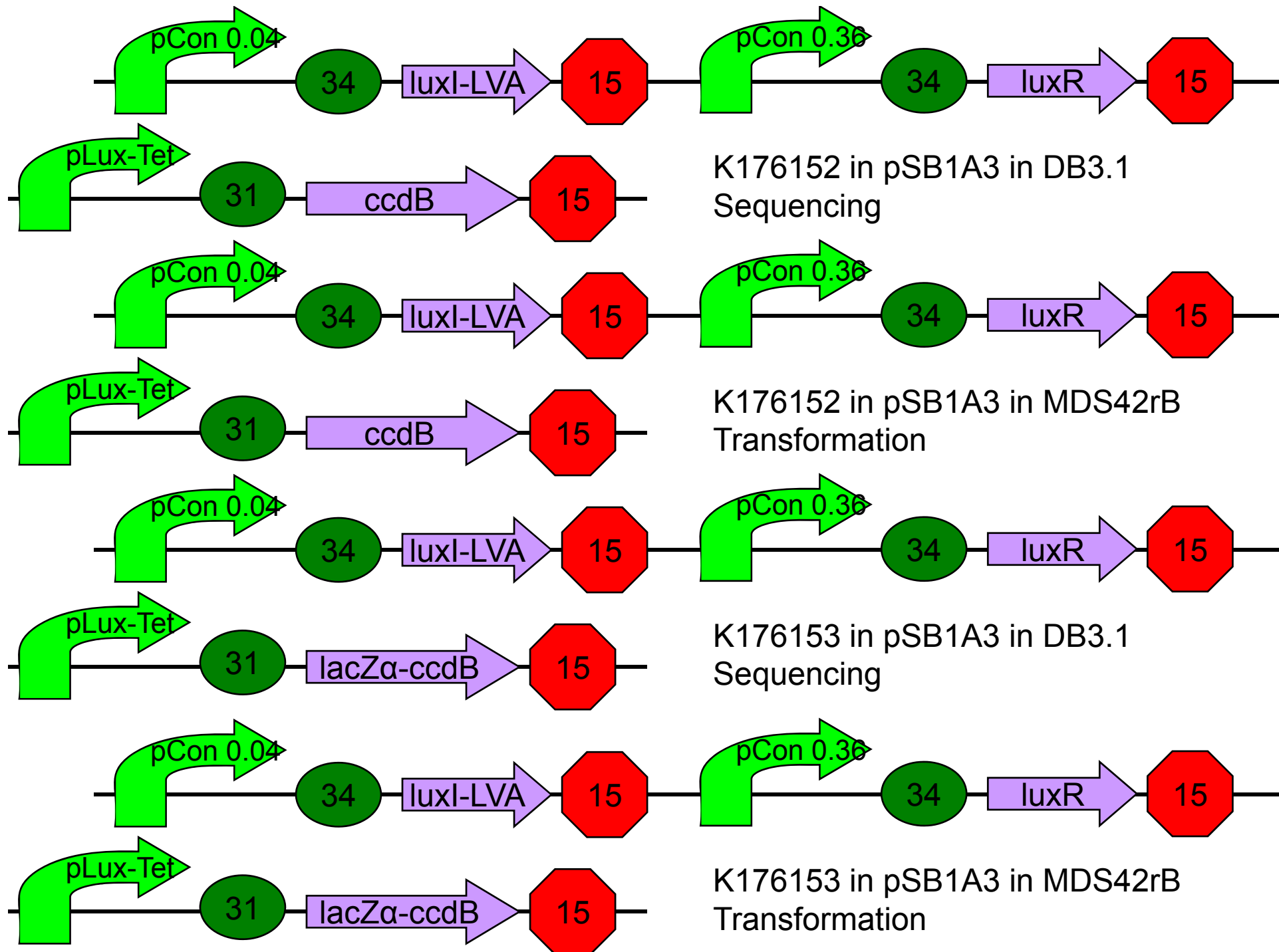

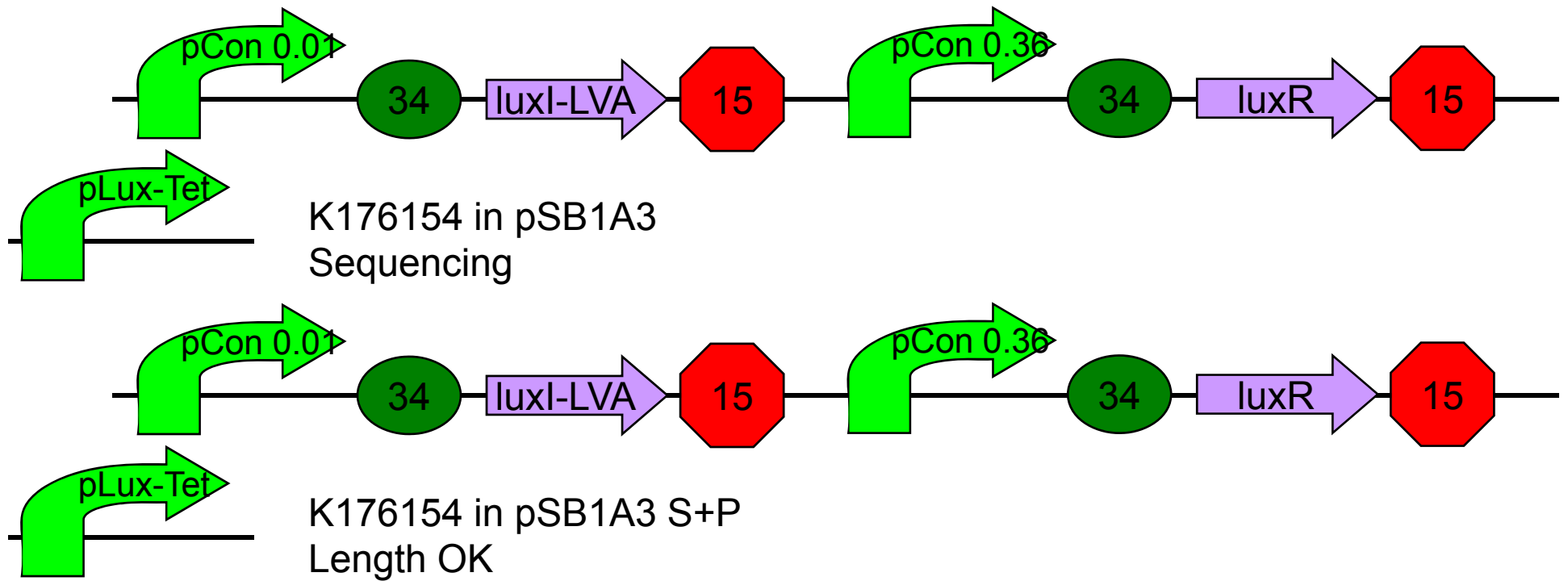

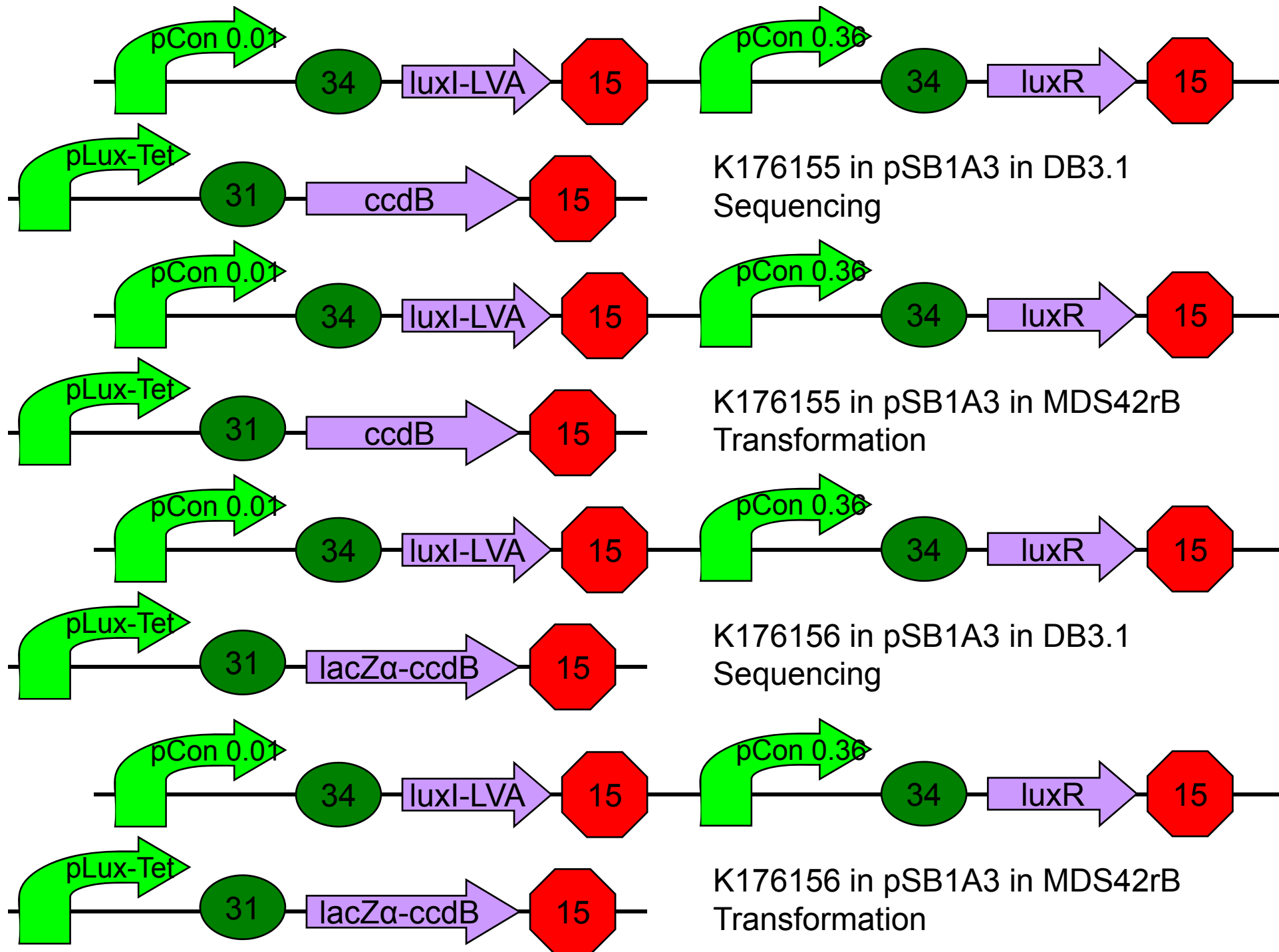

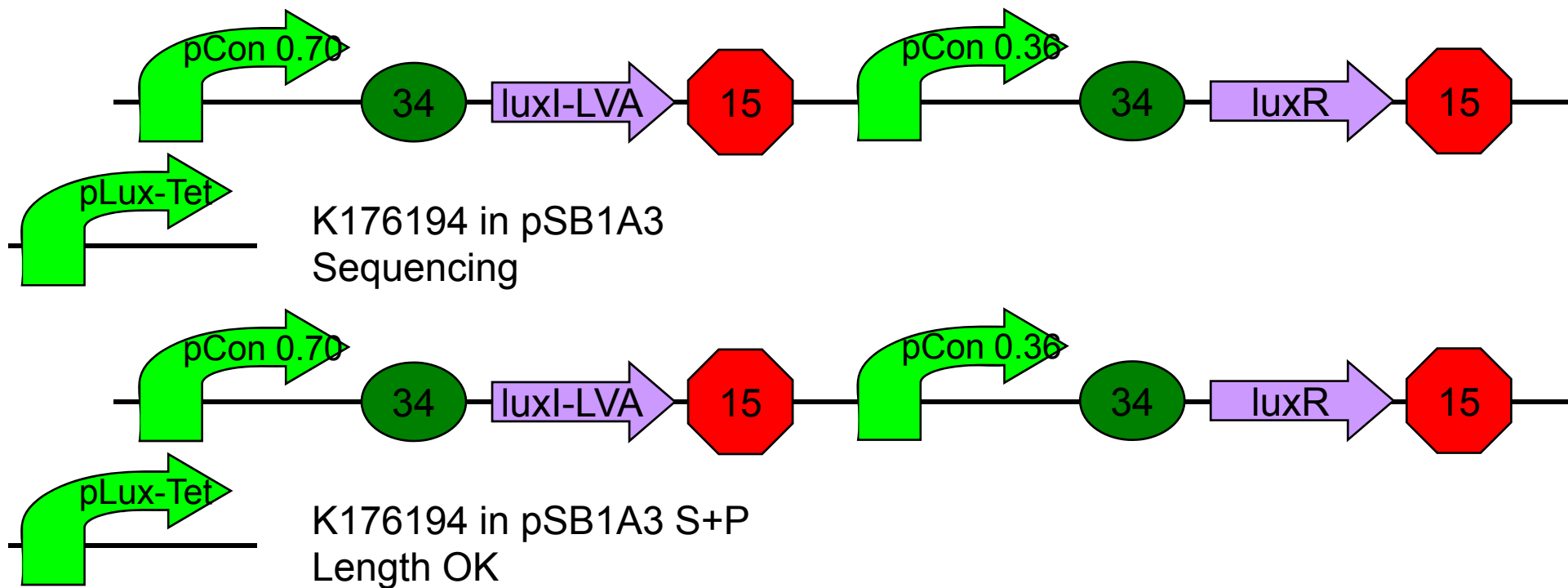

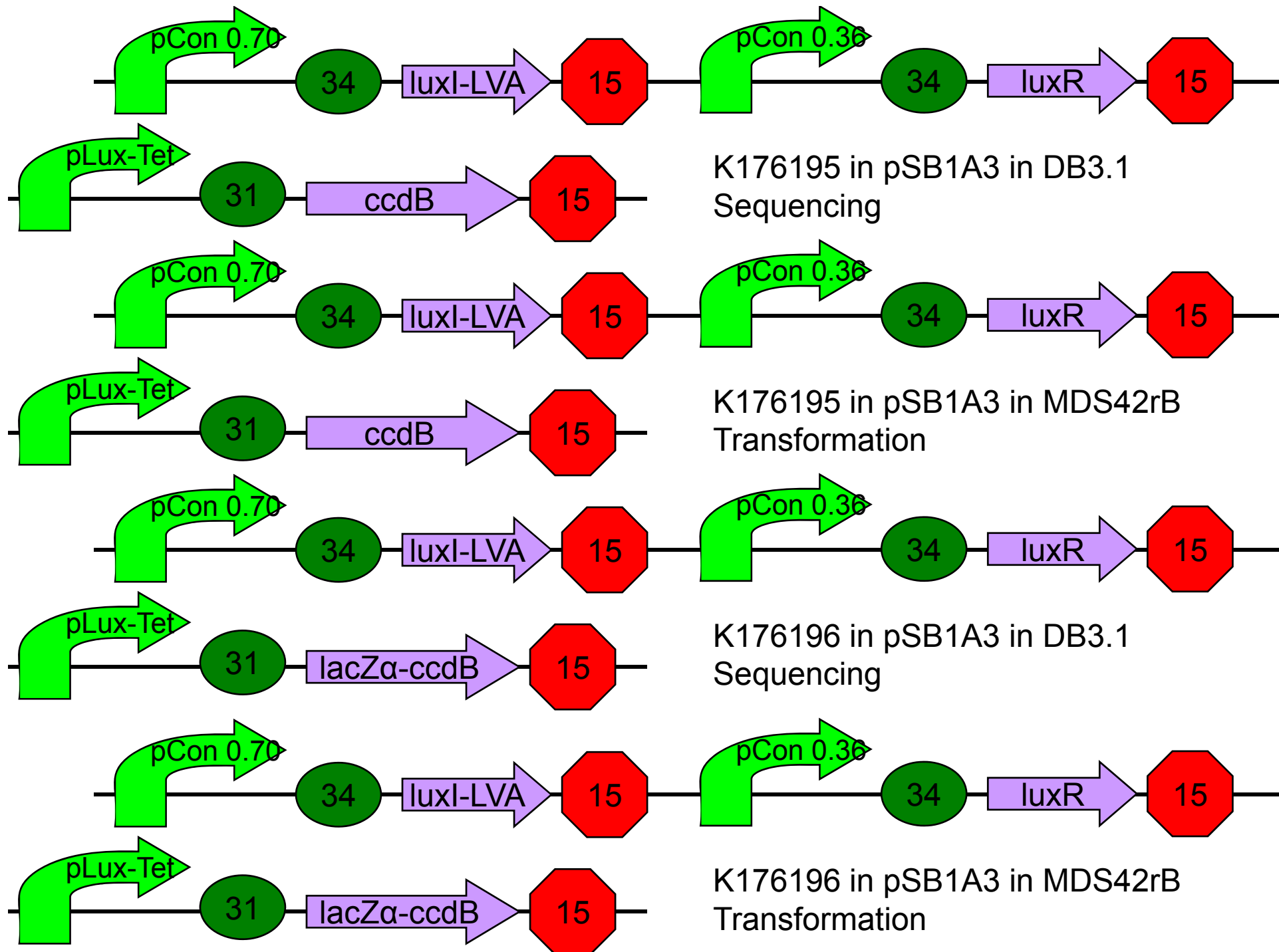

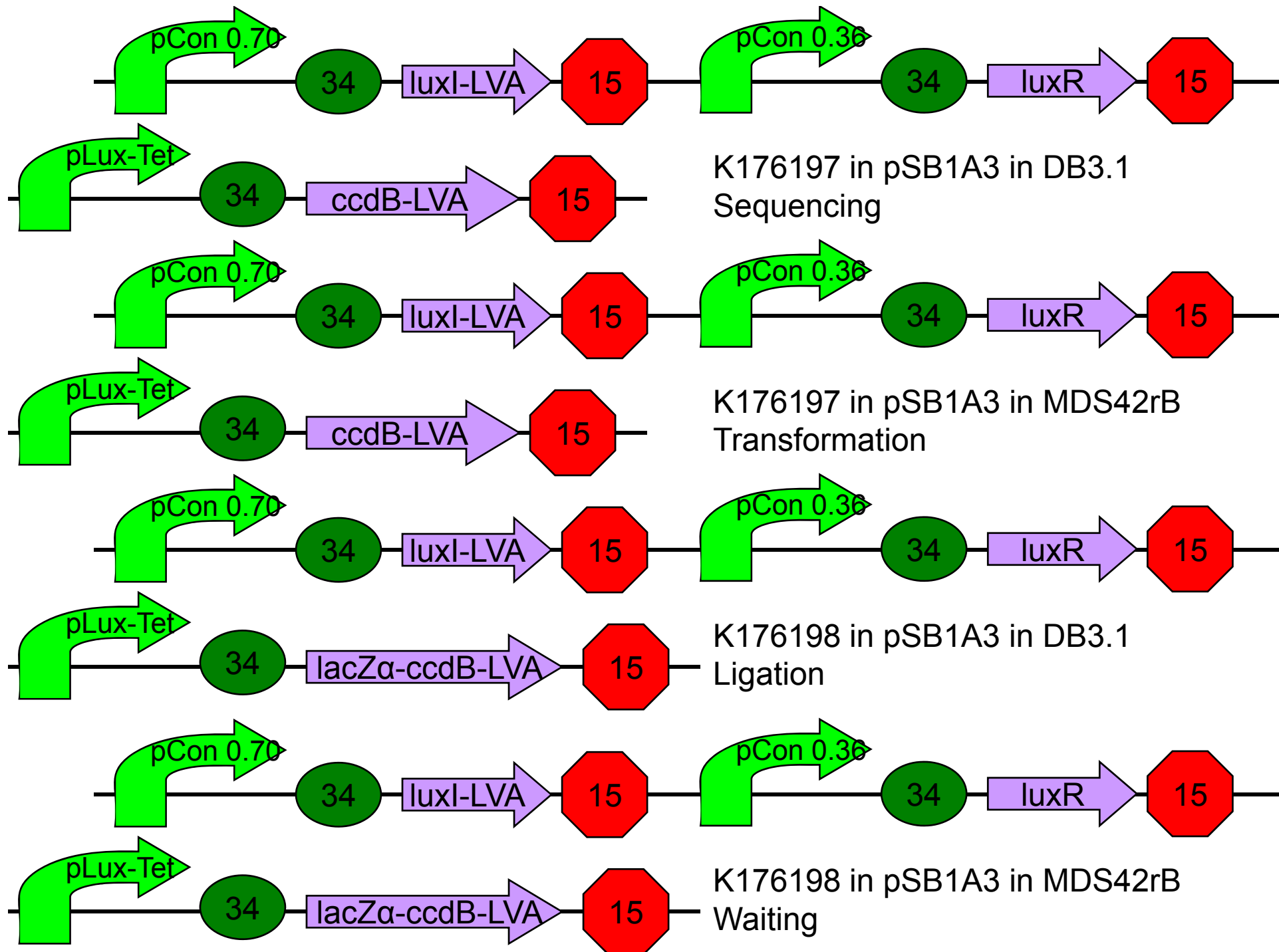

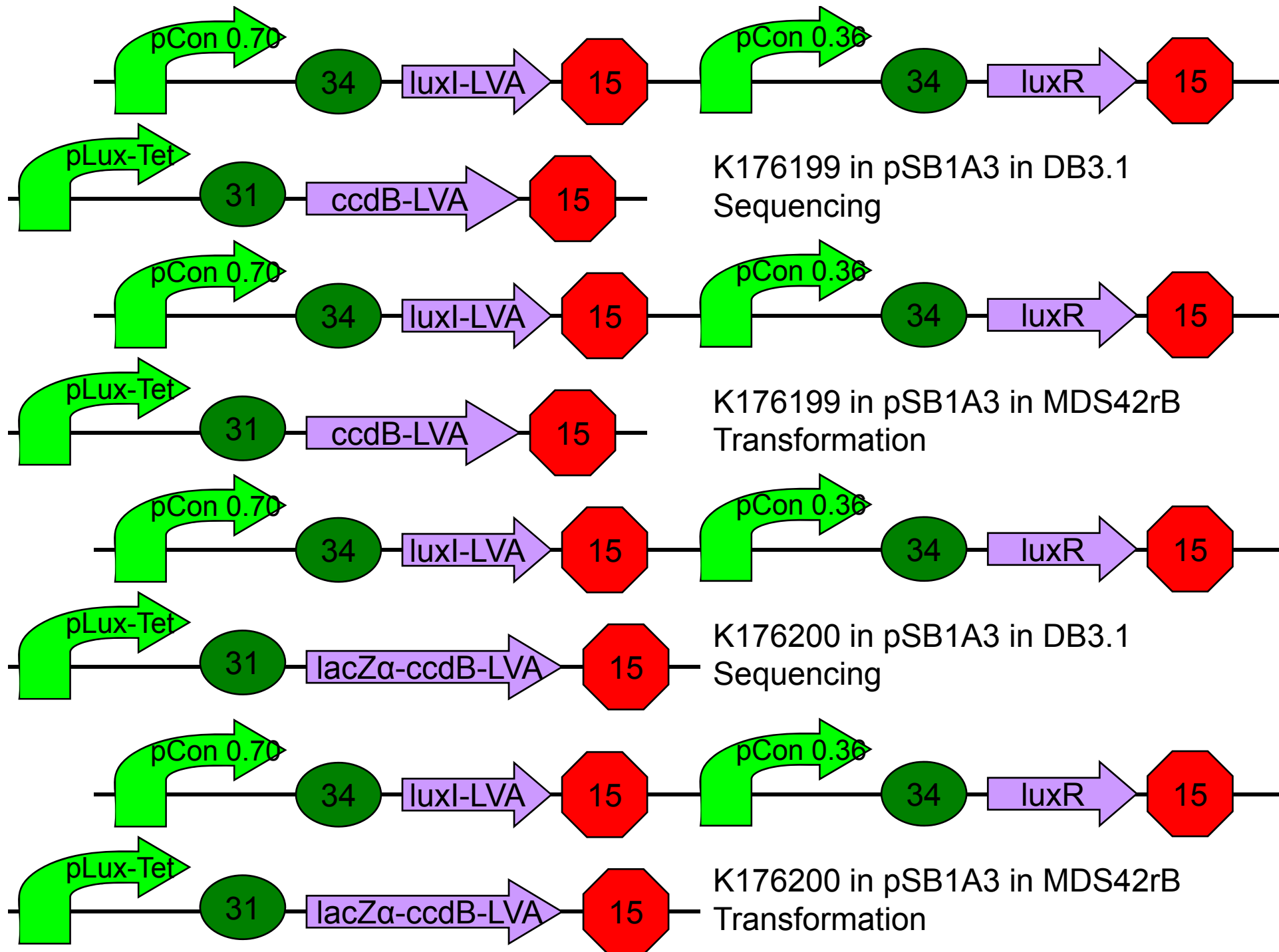

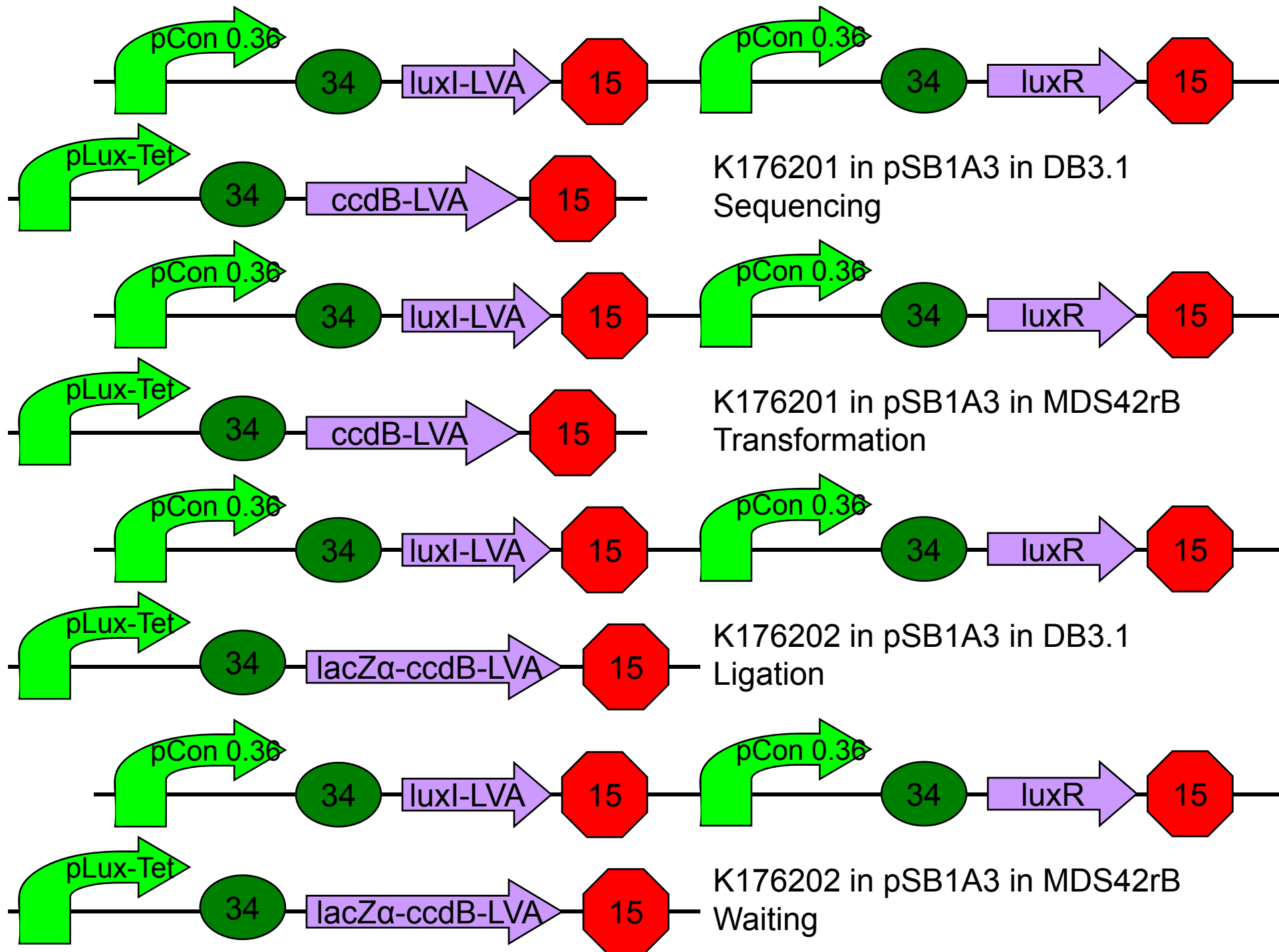



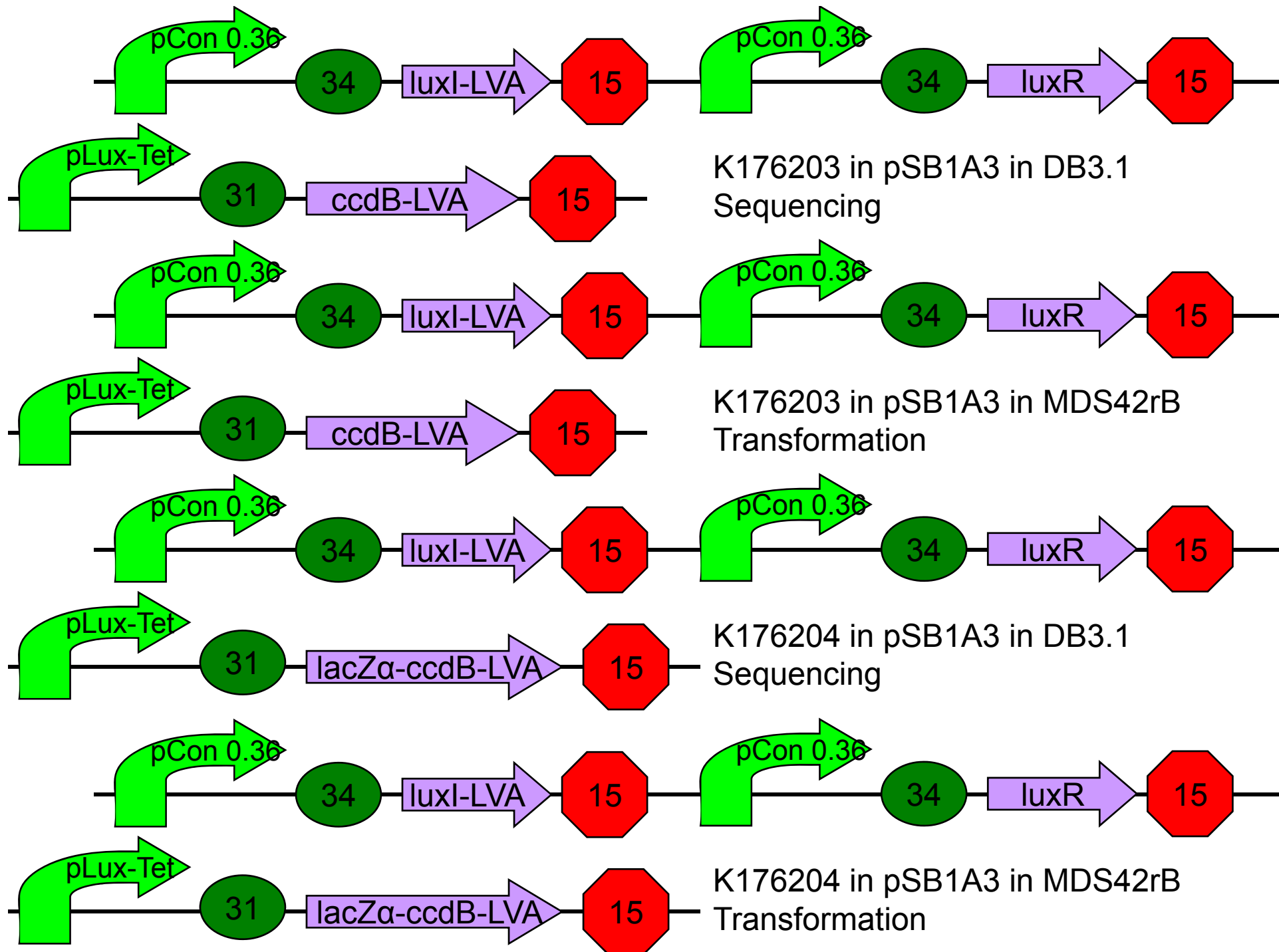

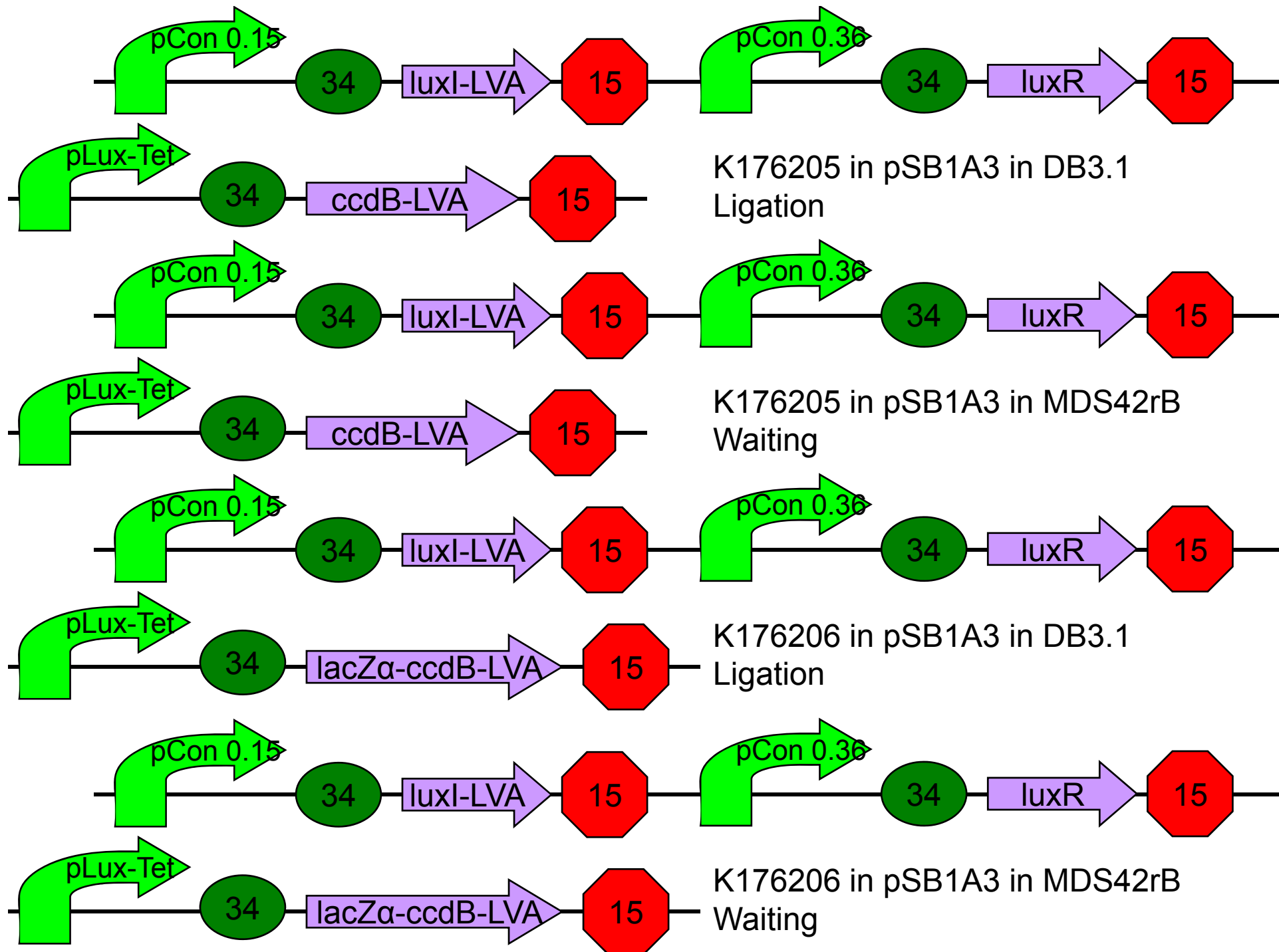

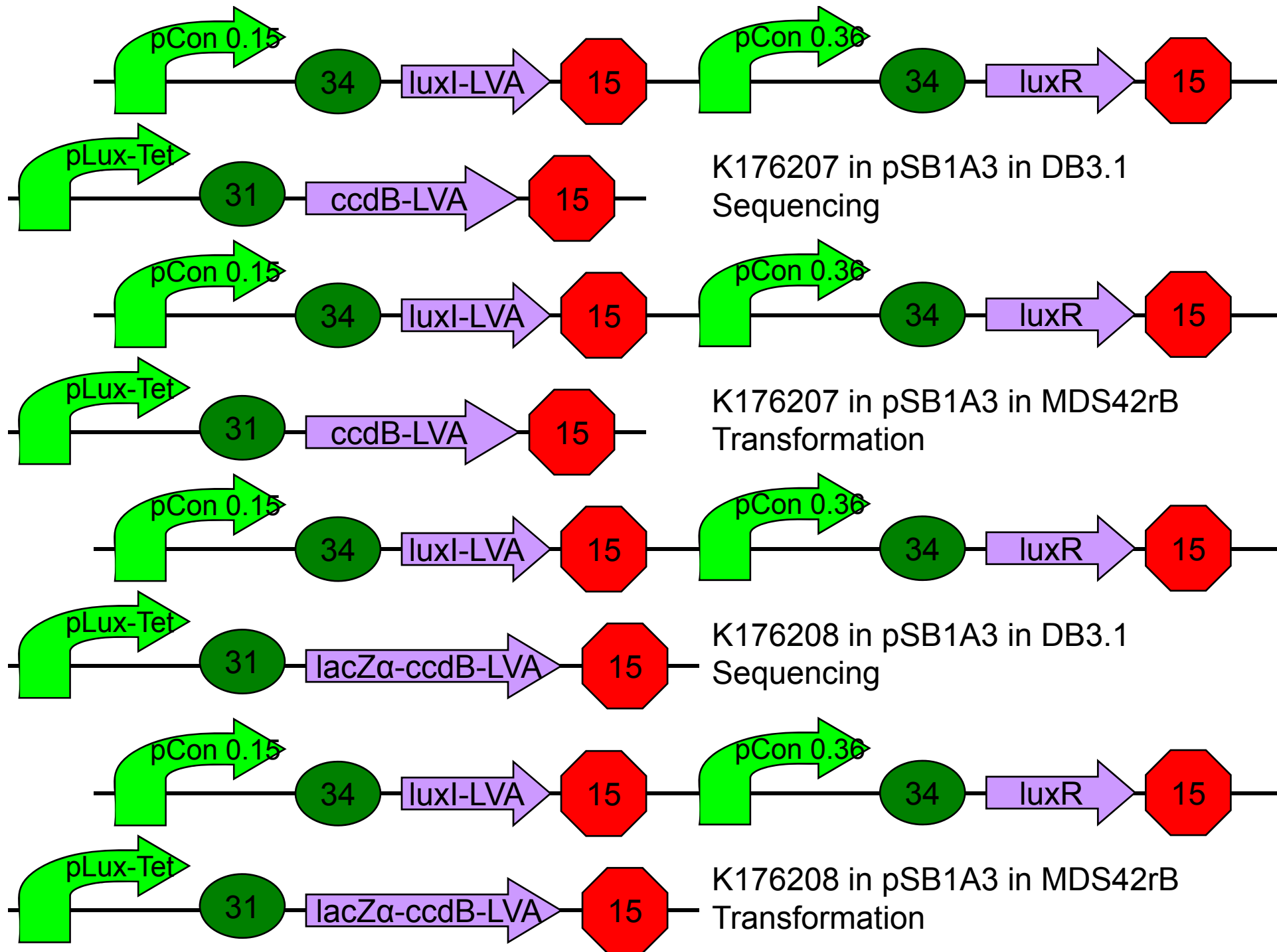

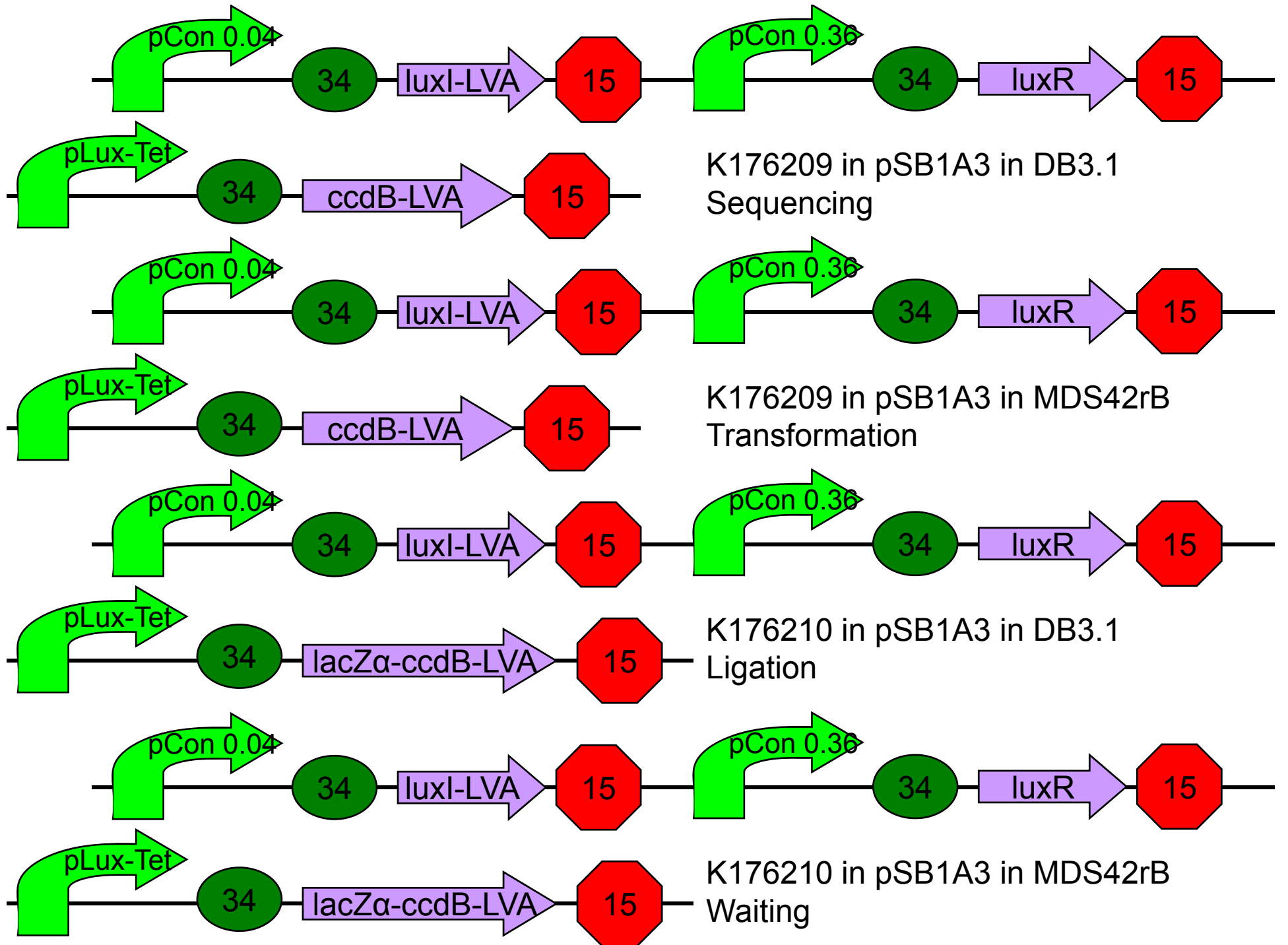

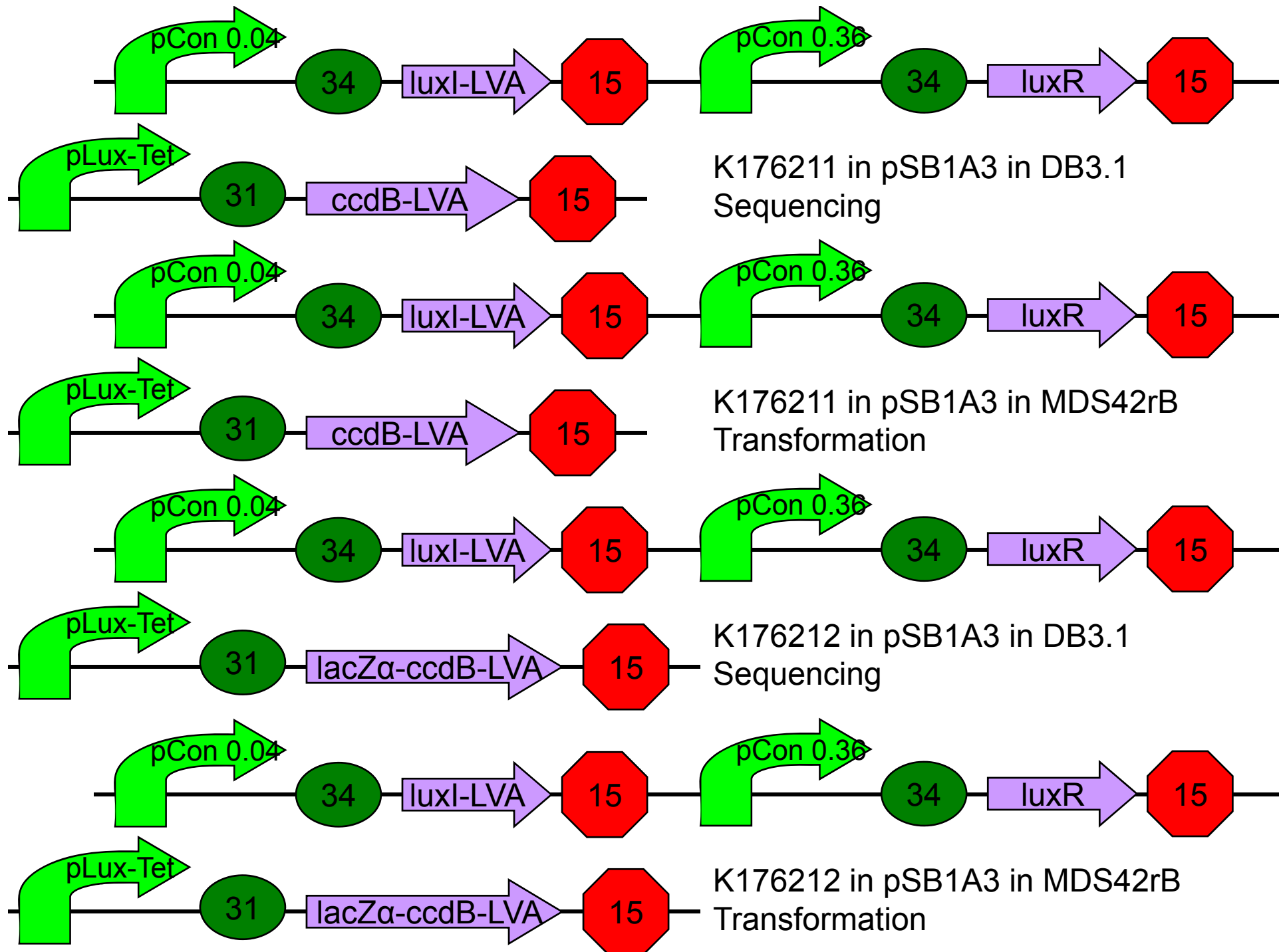

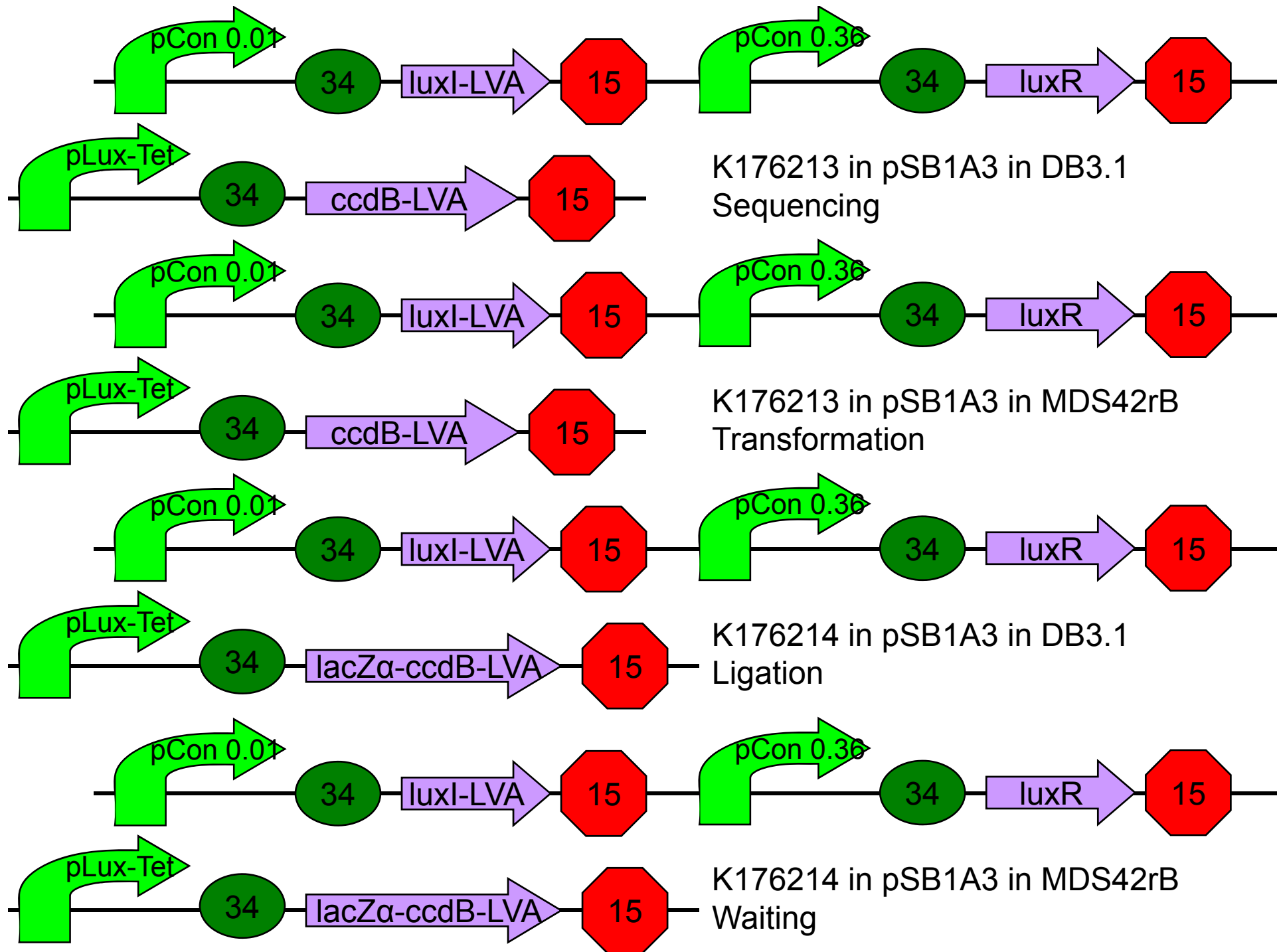

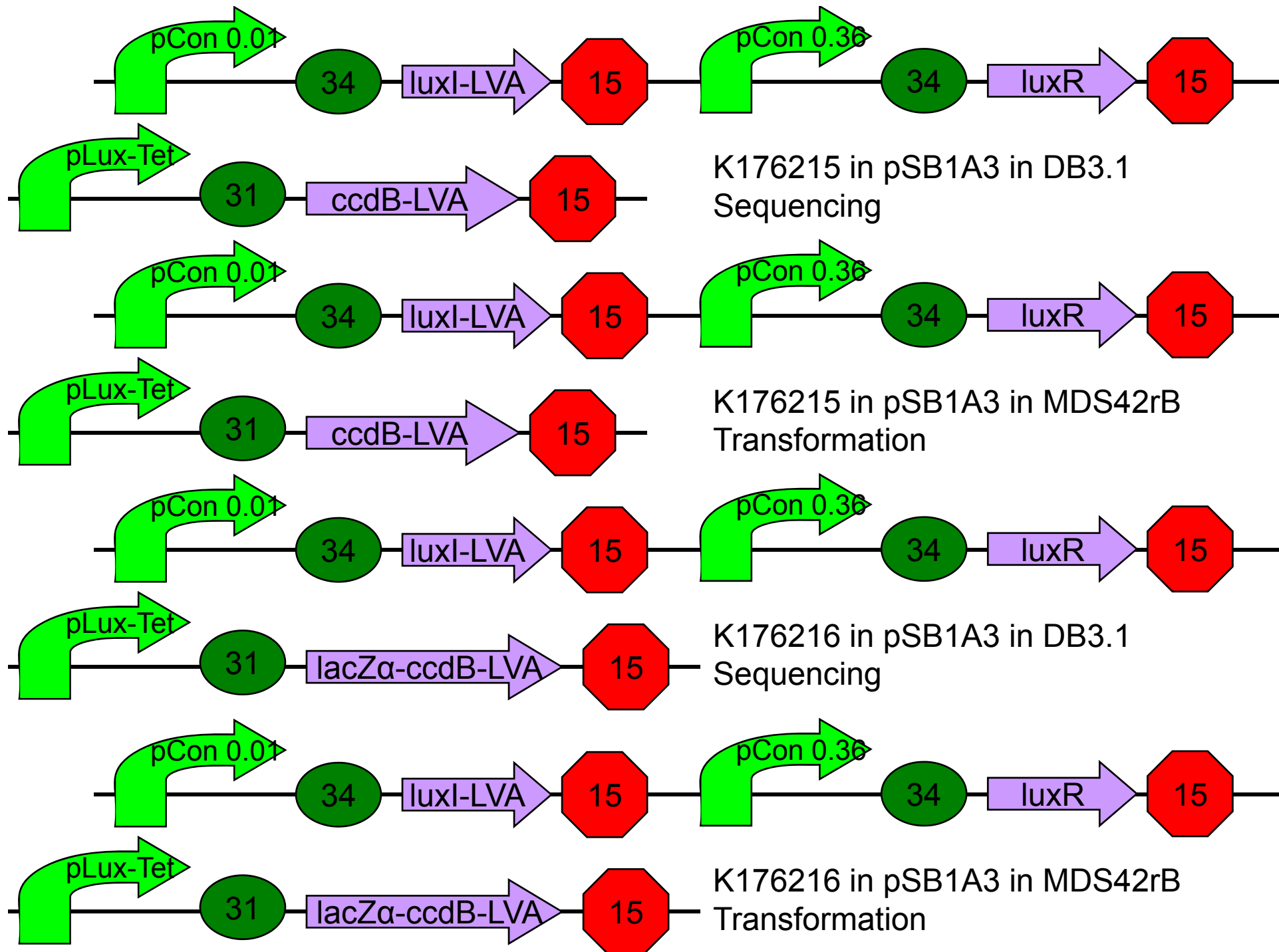

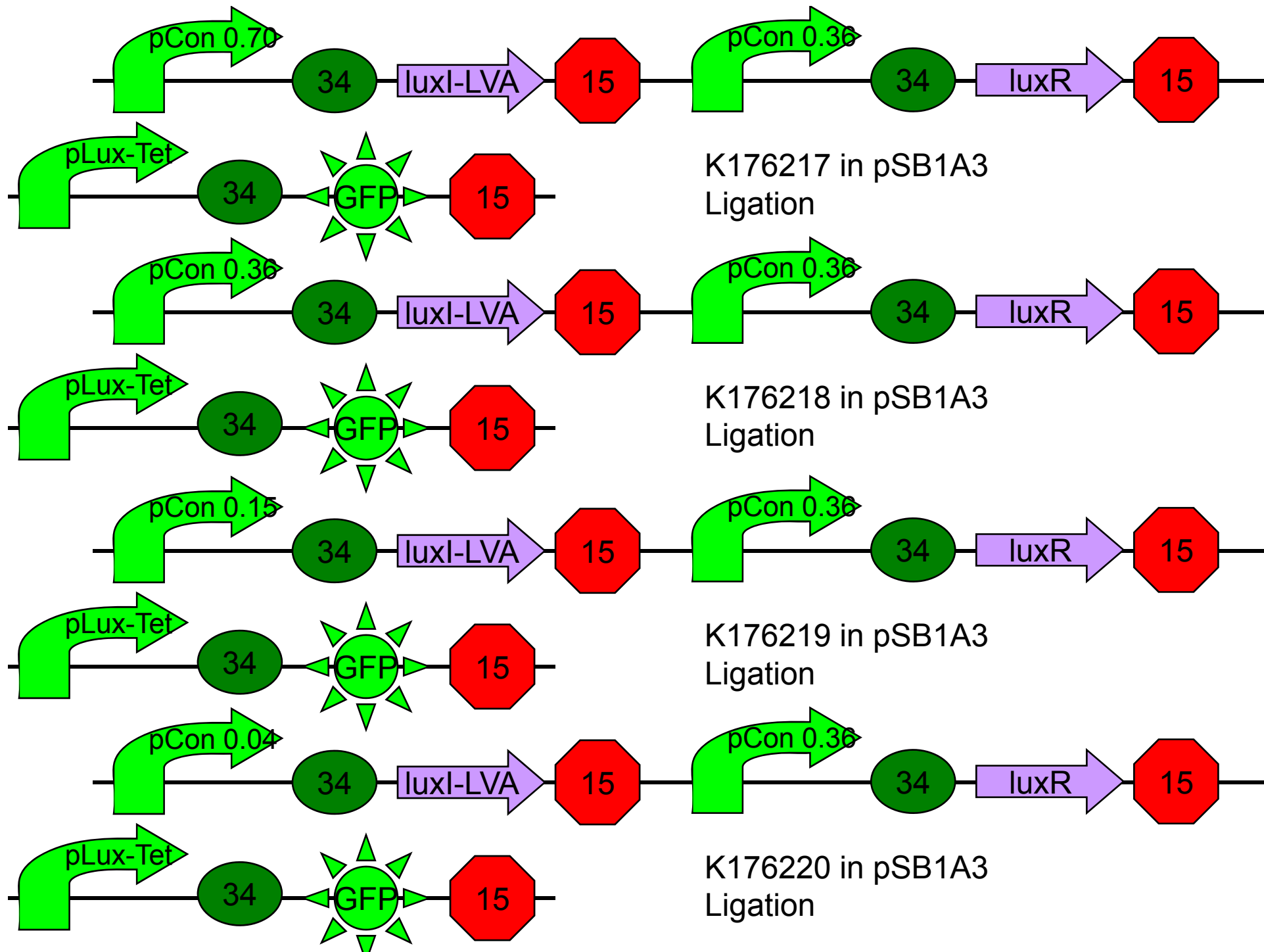



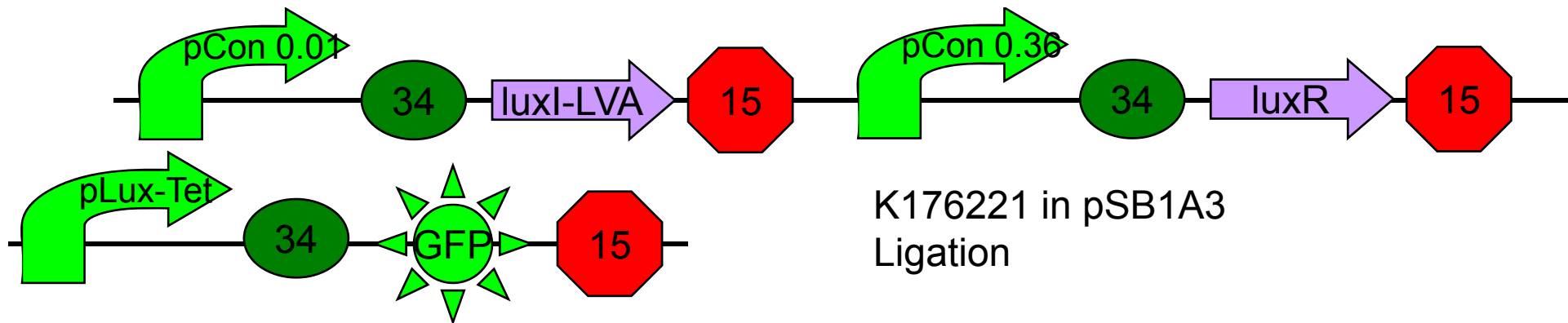

































15

	K176037 E+S Synthesis OK		K176037 in pSB1A3 Sequence OK		K176047 Synthesis OK
	K176038 E+S Synthesis OK		K176038 in pSB1A3 Sequence OK		K176048 Synthesis OK
	K176039 E+S Synthesis OK		K176039 in pSB1A3 Sequence OK		K176049 Synthesis OK
	K176040 E+S Synthesis OK		K176040 in pSB1A3 Sequence OK		K176050 Synthesis OK
	K176041 E+S Synthesis OK		K176041 in pSB1A3 Sequence OK		K176051 Synthesis OK
	K176042 E+S Synthesis OK		K176042 in pSB1A3 Sequencing		K176052 Synthesis OK
	K176043 E+S Synthesis OK		K176043 in pSB1A3 Sequence OK		K176053 Synthesis OK
	K176044 E+S Synthesis OK		K176044 in pSB1A3 Sequence OK		K176054 Synthesis OK
	K176045 E+S Synthesis OK		K176045 in pSB1A3 Sequence OK		K176055 Synthesis OK
	K176046 E+S Synthesis OK		K176046 in pSB1A3 Sequence OK		K176056 Synthesis OK
—	pSB1A3 E+S Length OK				

16

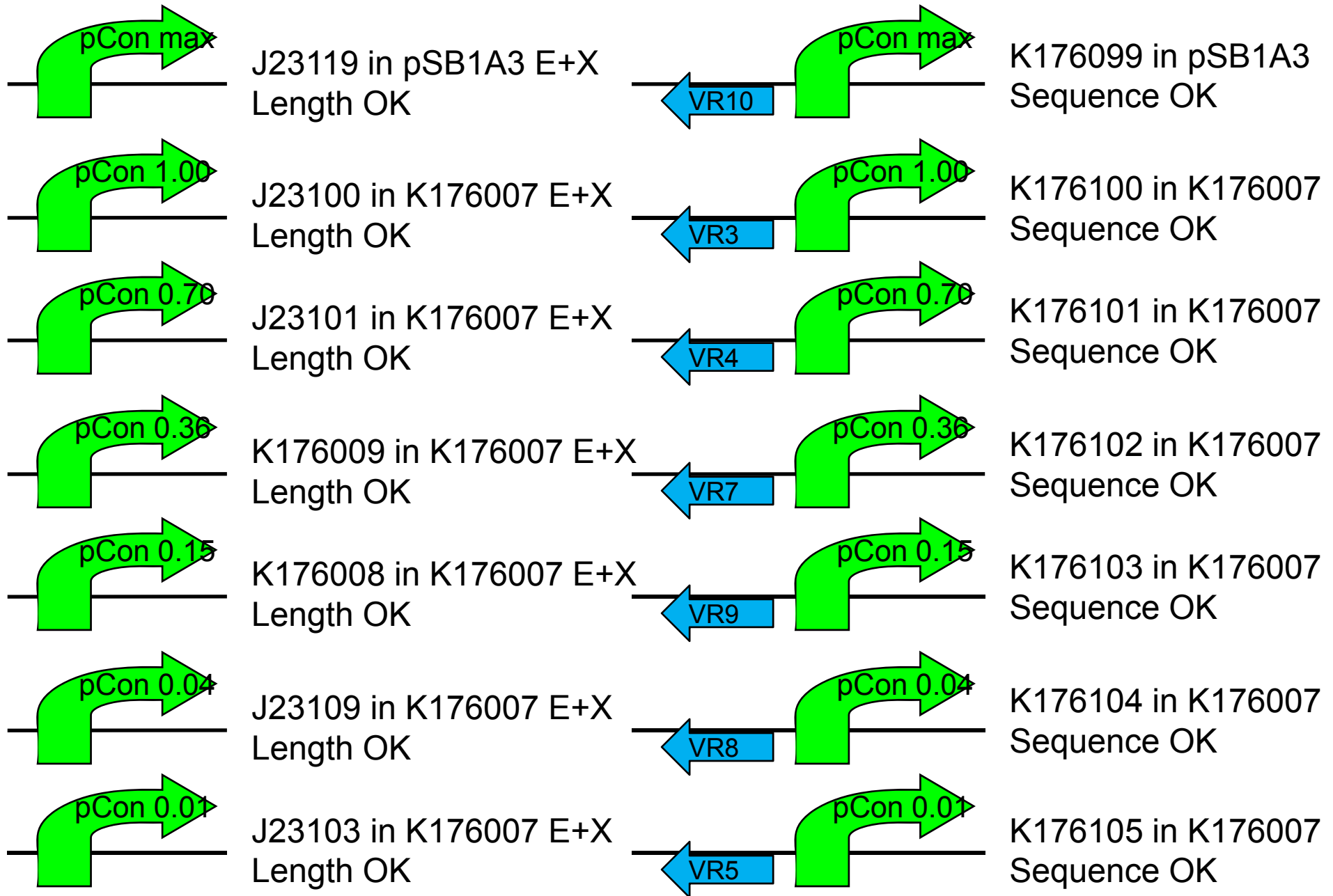

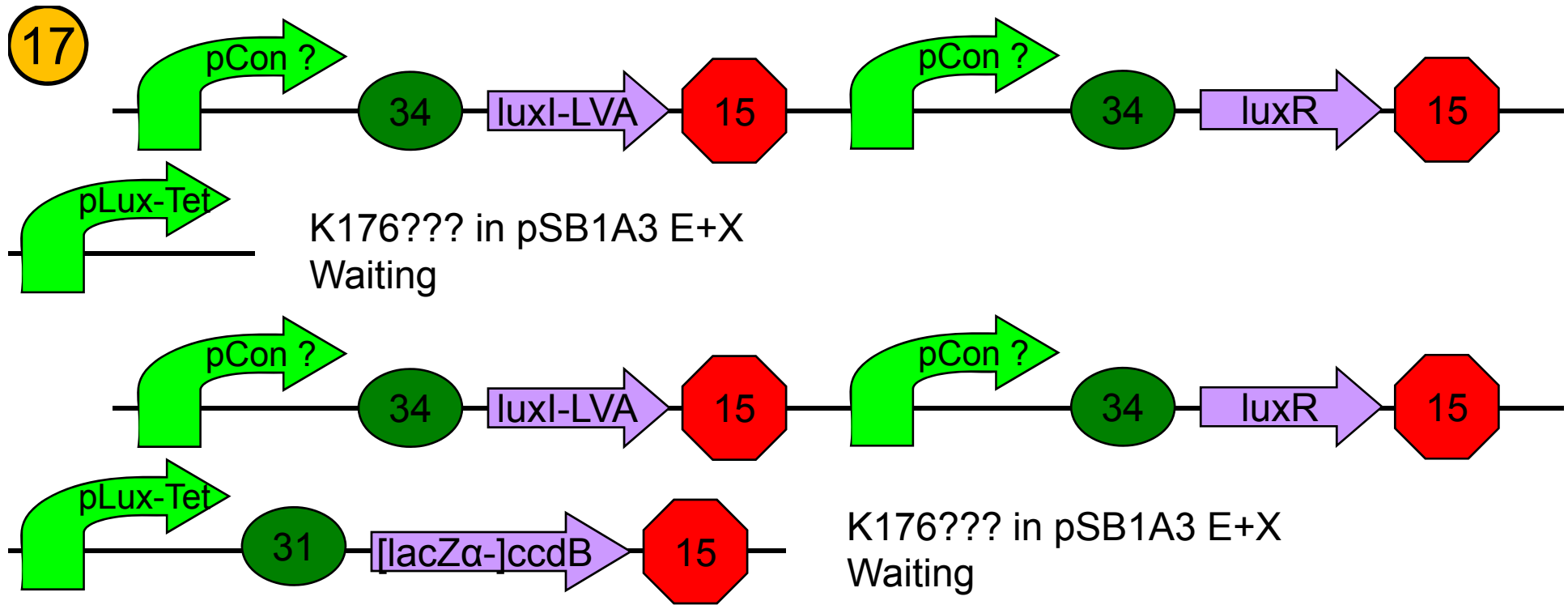

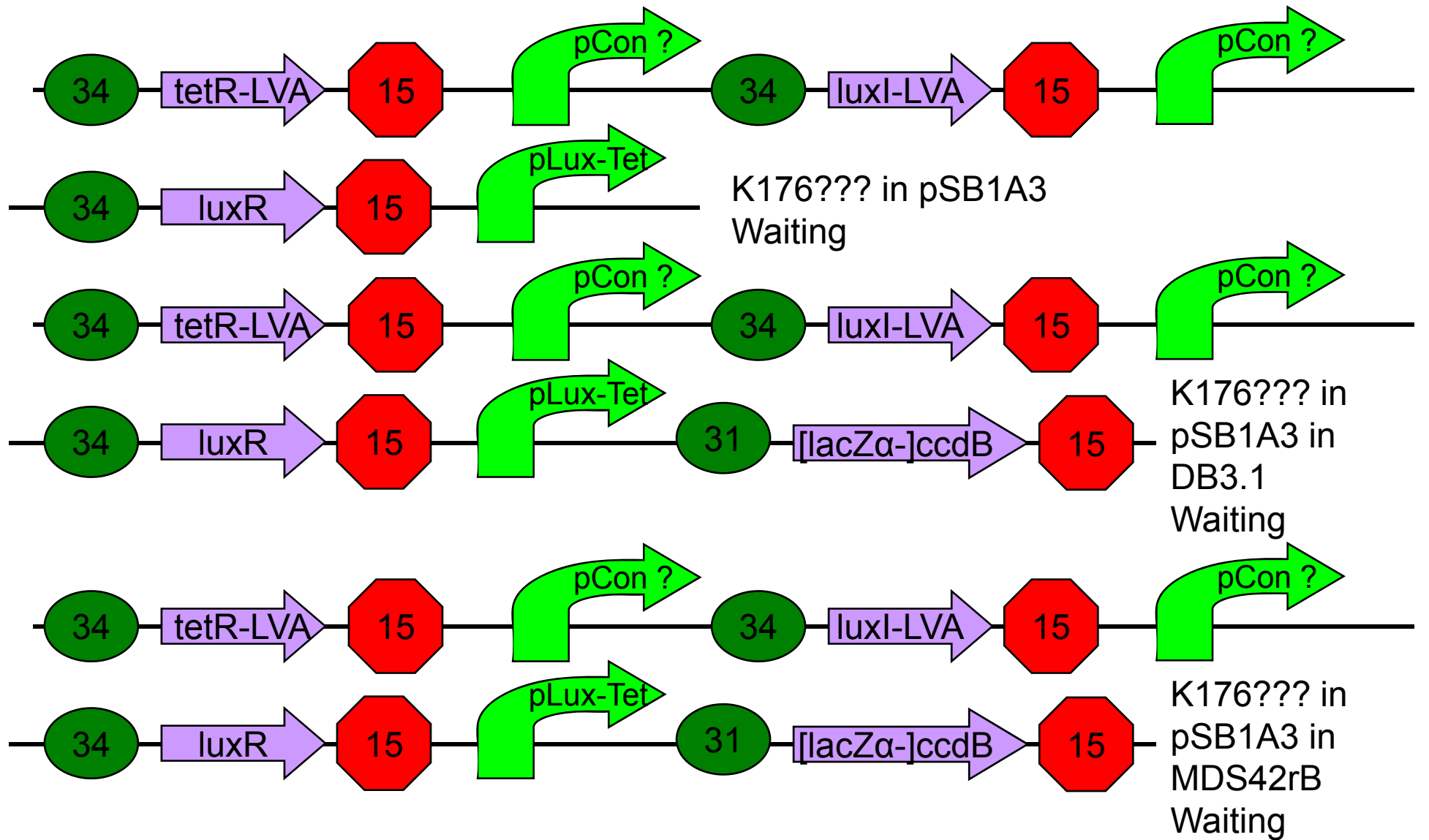

18

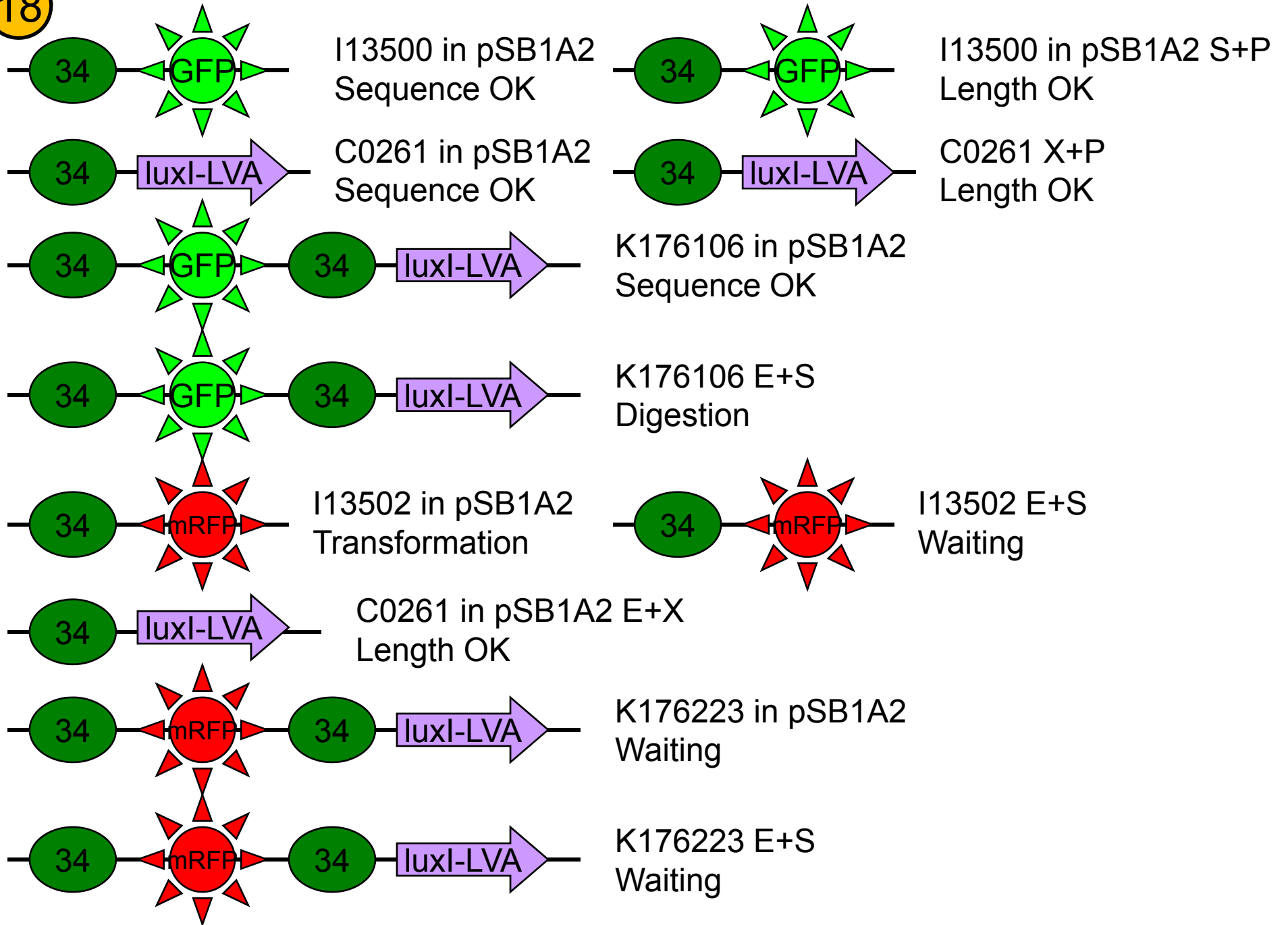

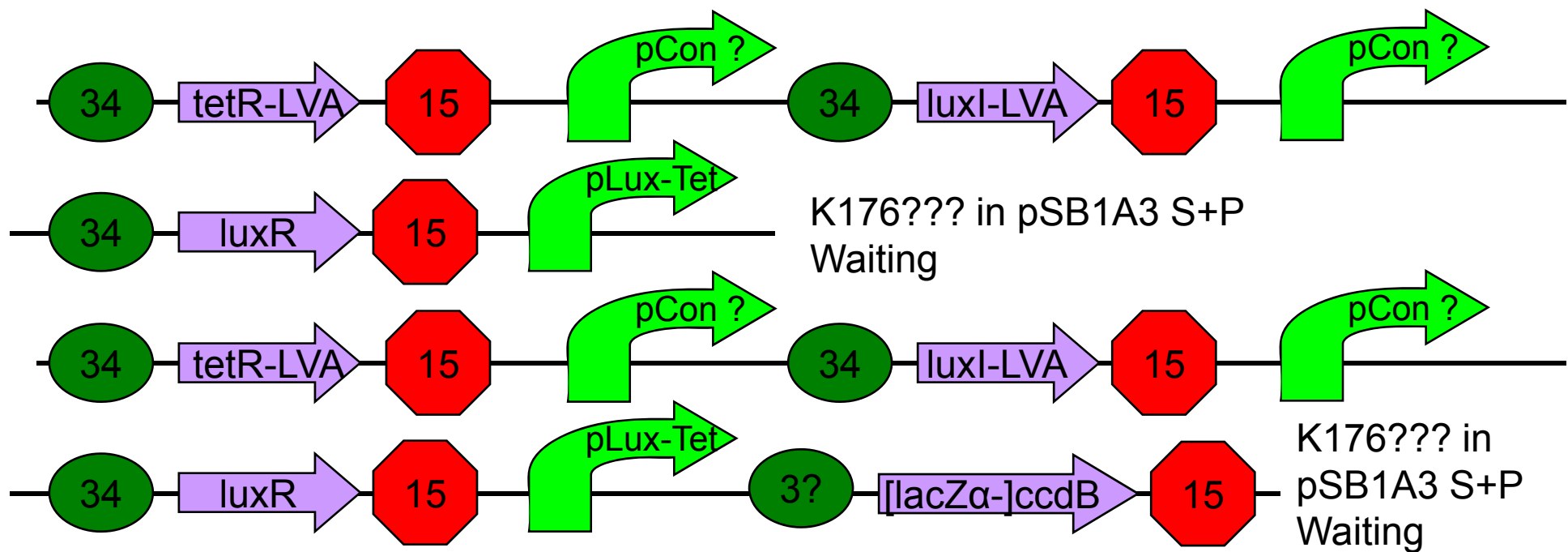

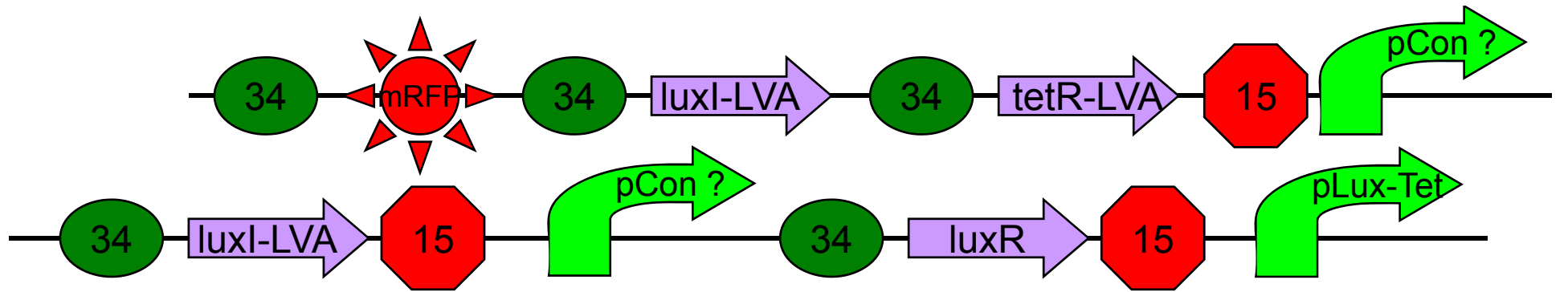

K176??? in pSB1A3  
Waiting

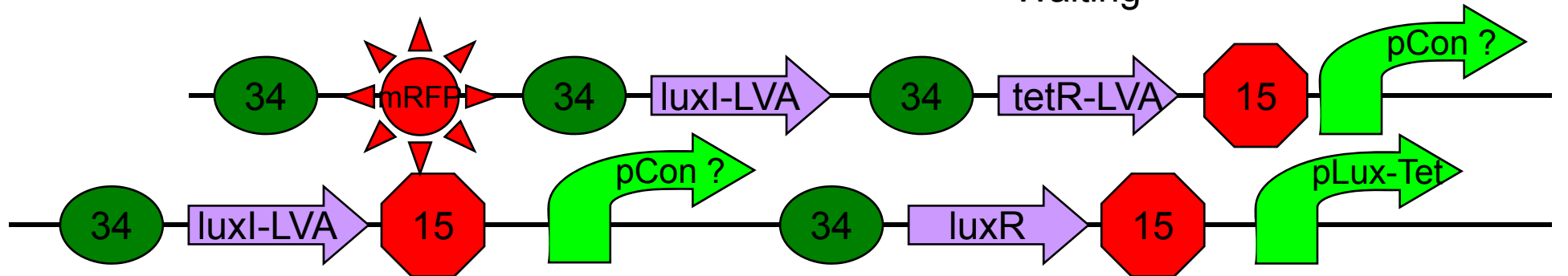

K176??? in pSB1A3 in DB3.1  
Waiting

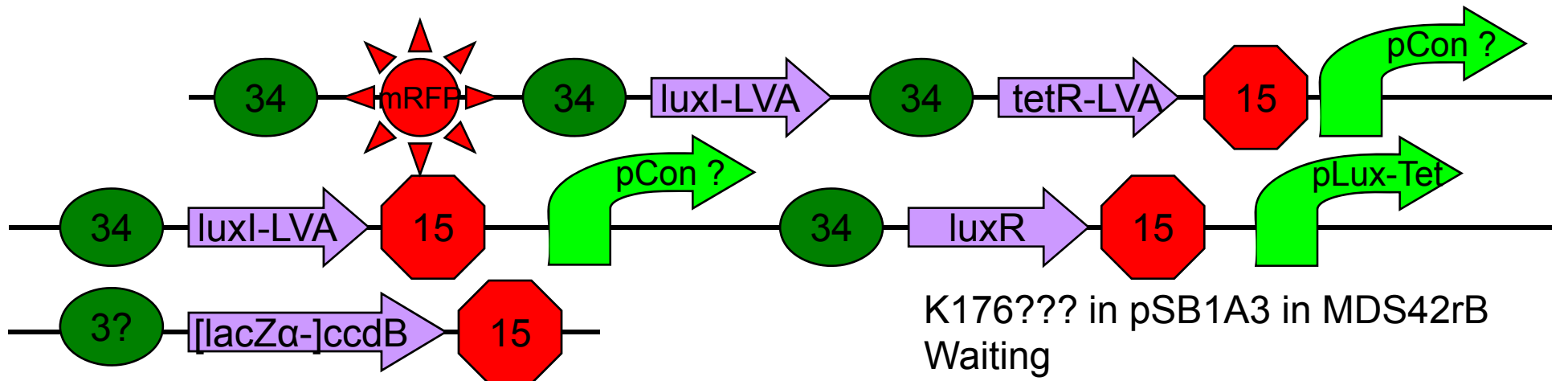

K176??? in pSB1A3 in MDS42rB  
Waiting



19

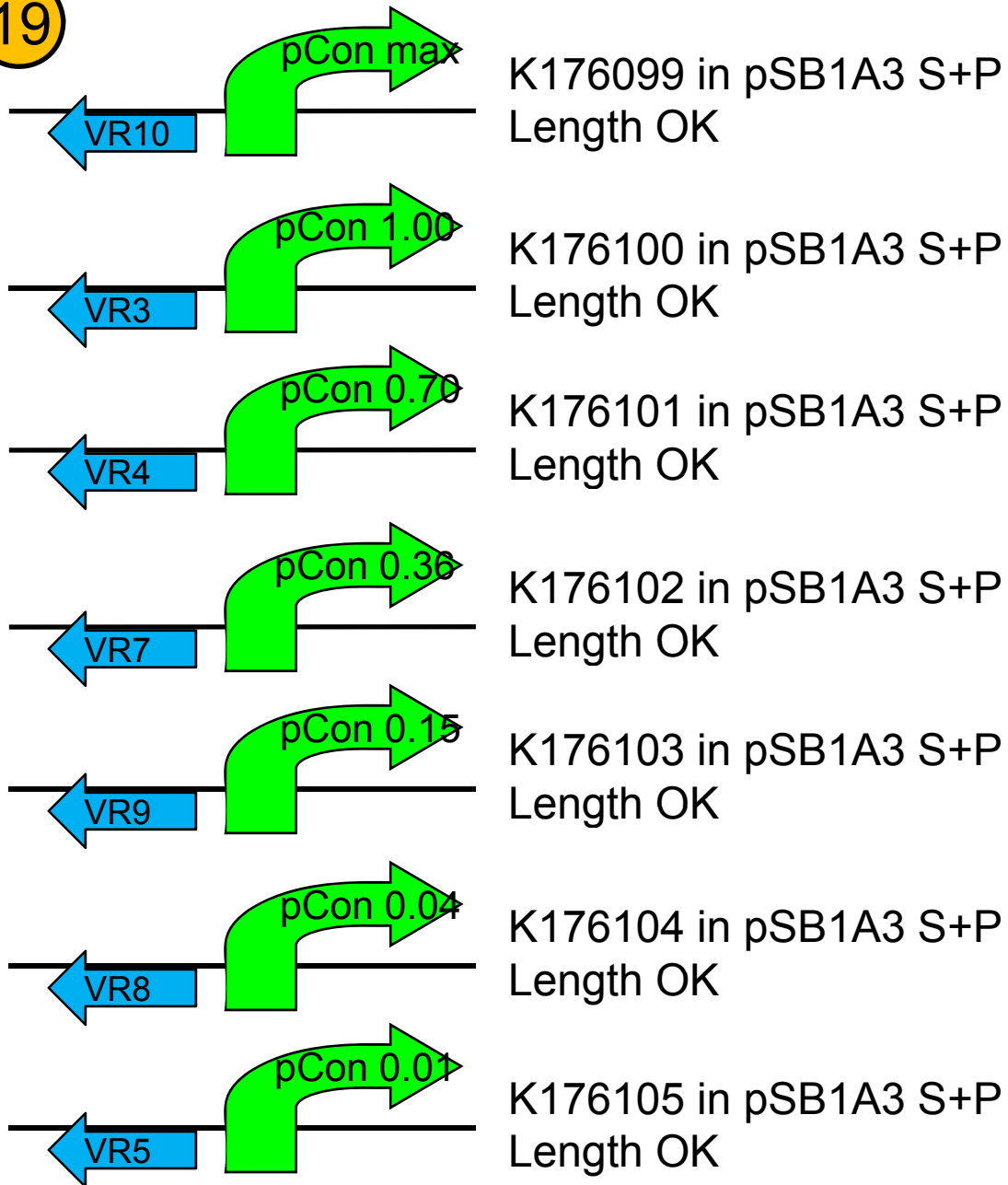



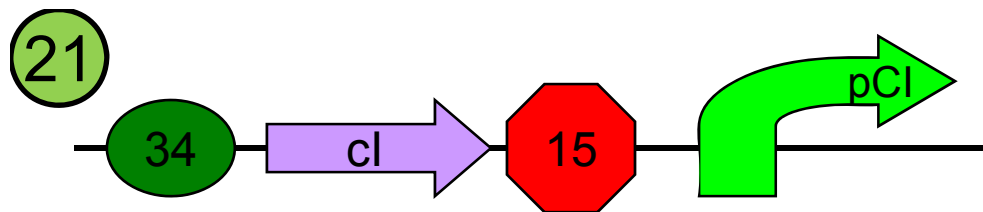

Q04510 in pSB2K3  
Sequence OK

22

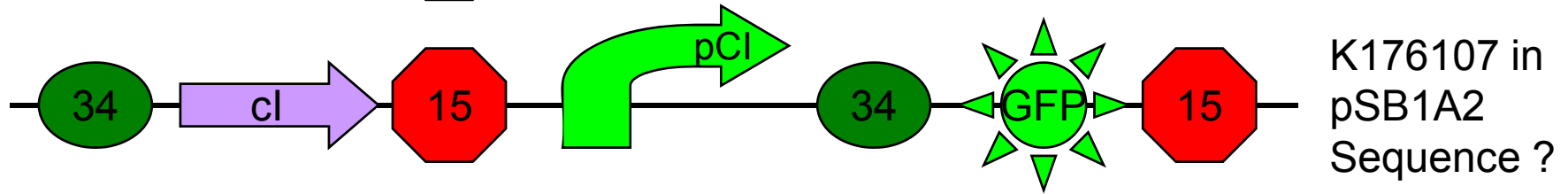
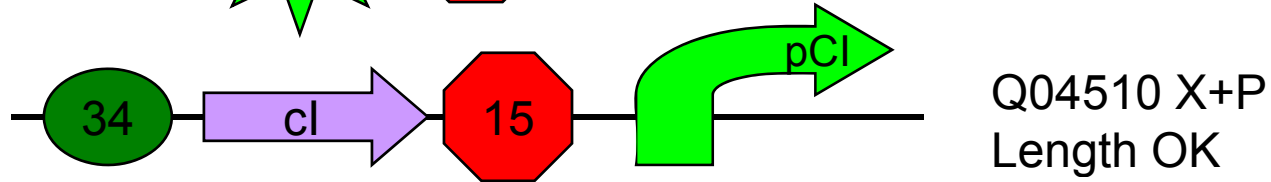
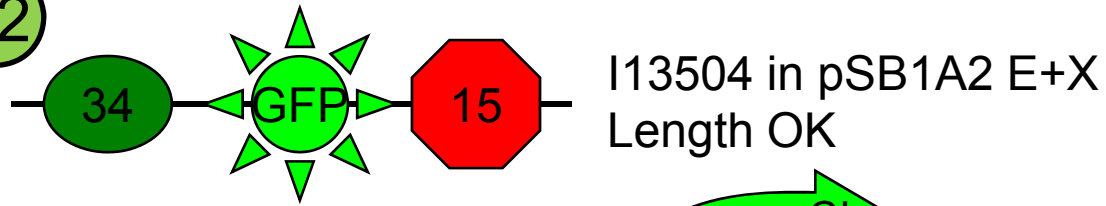

23

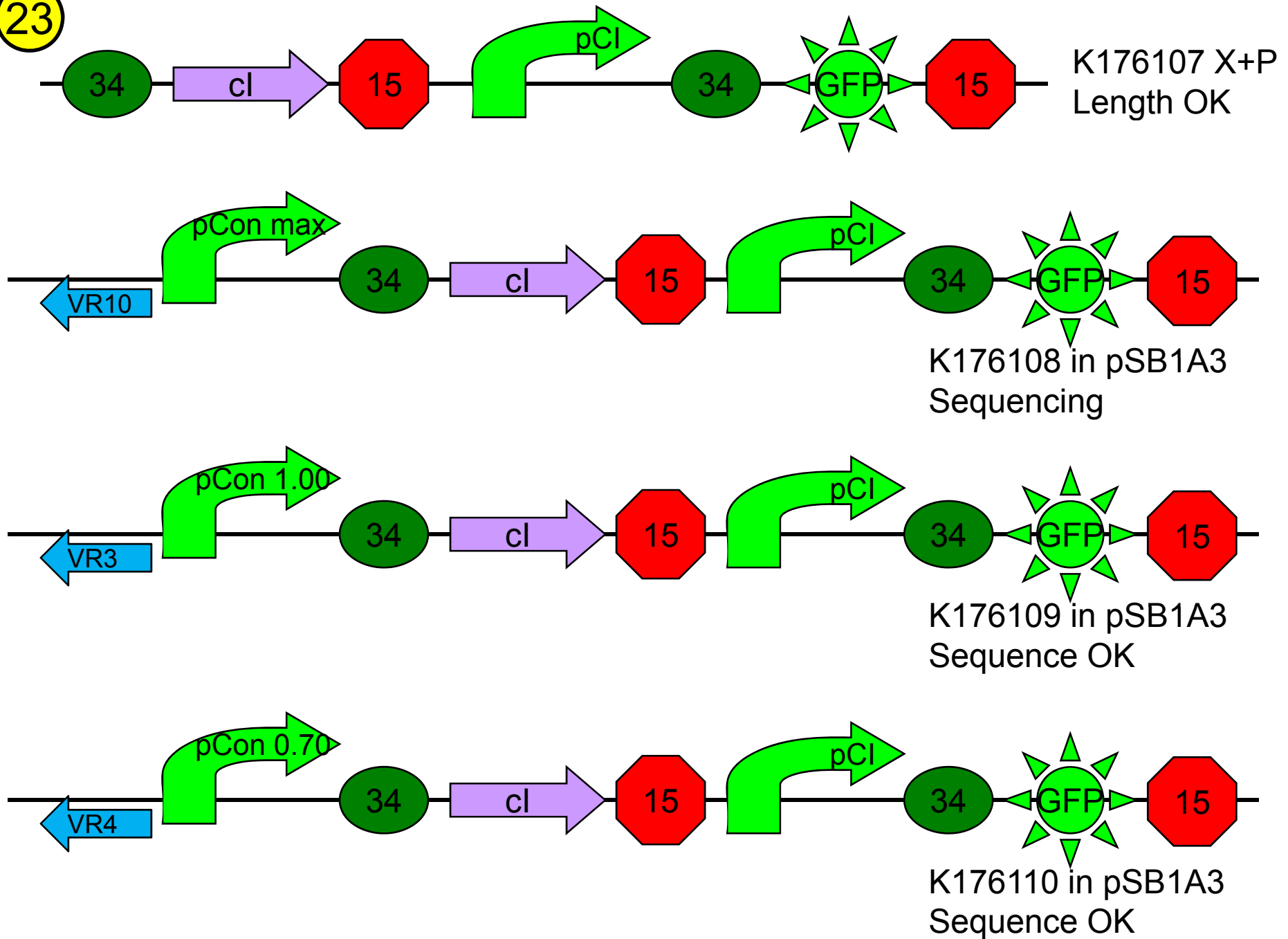

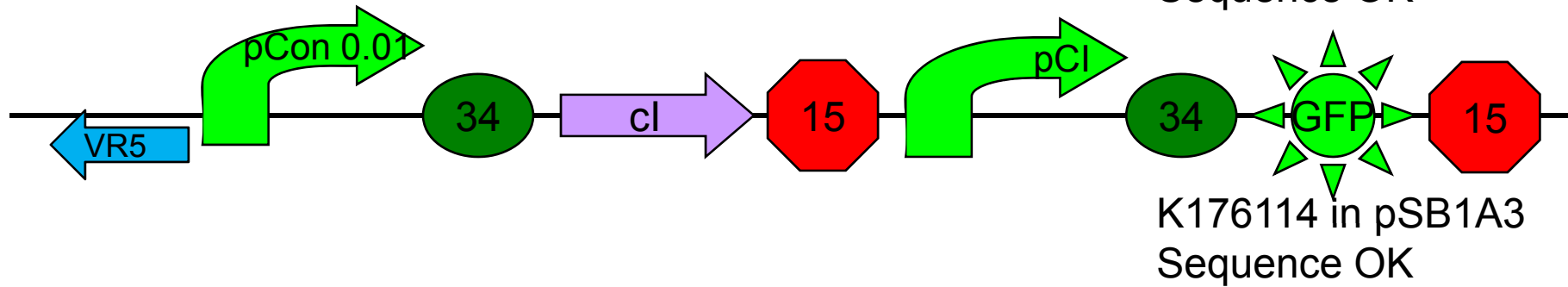
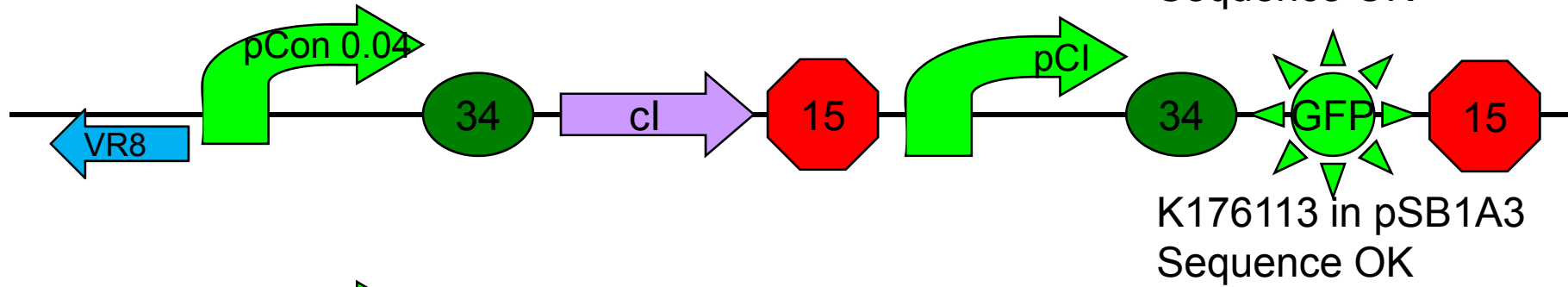
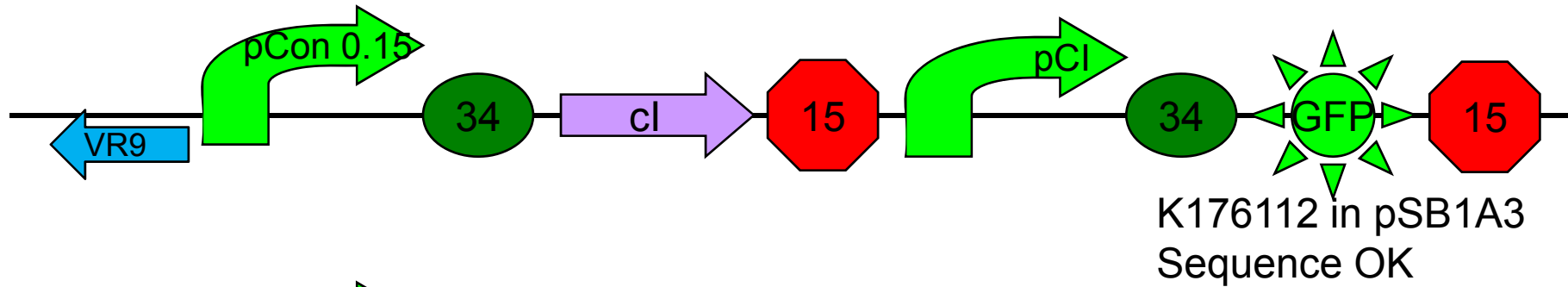
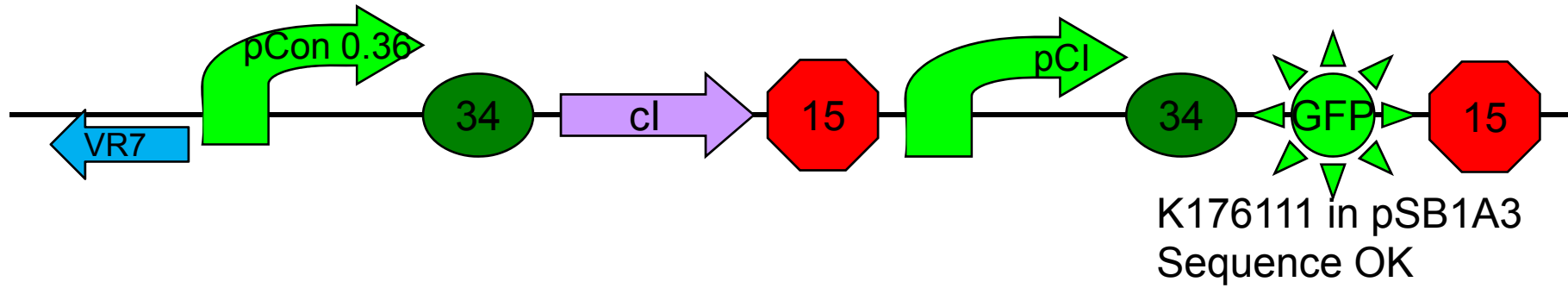

# MDS42 recA Blue

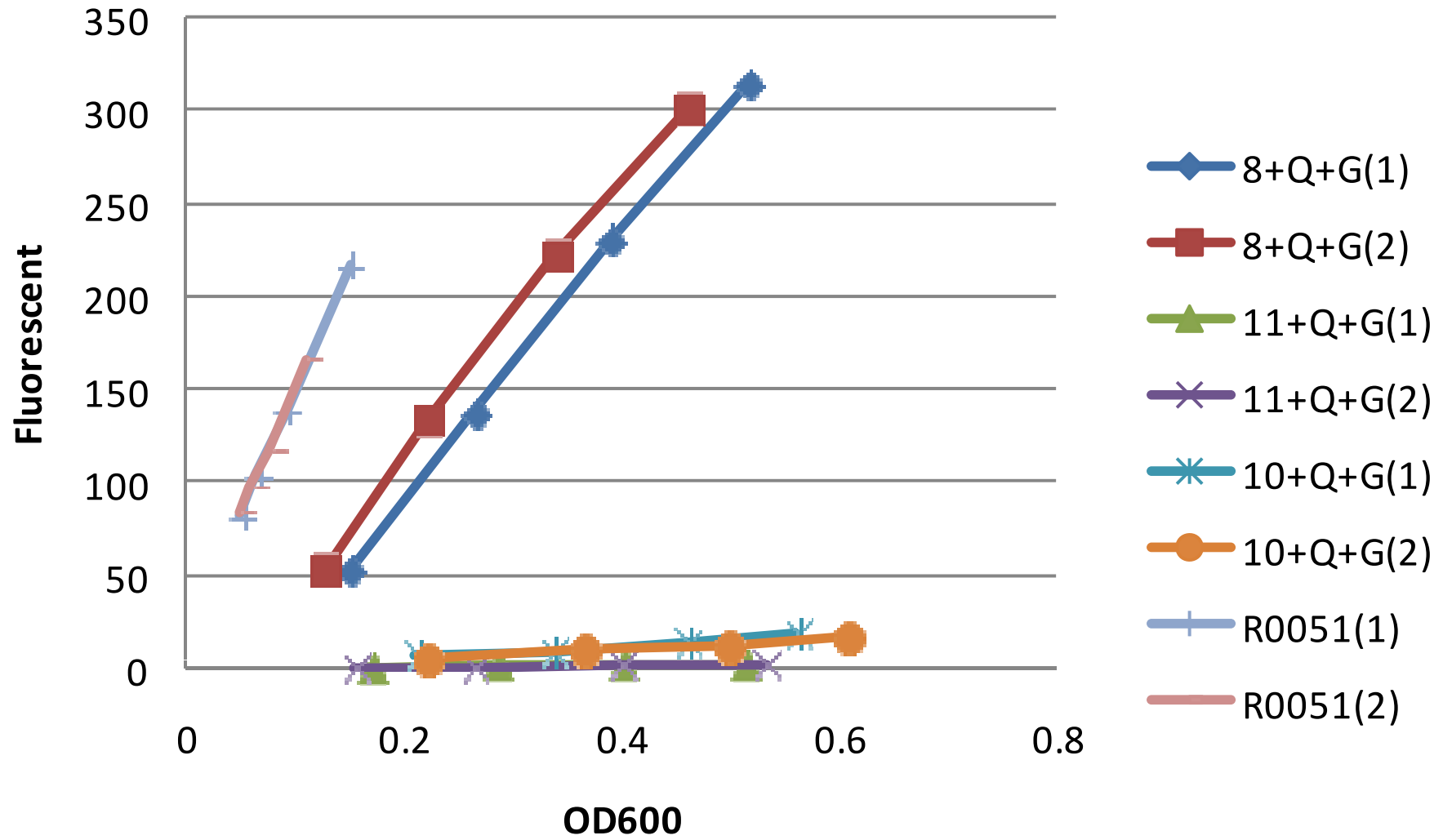

# Transfer Function

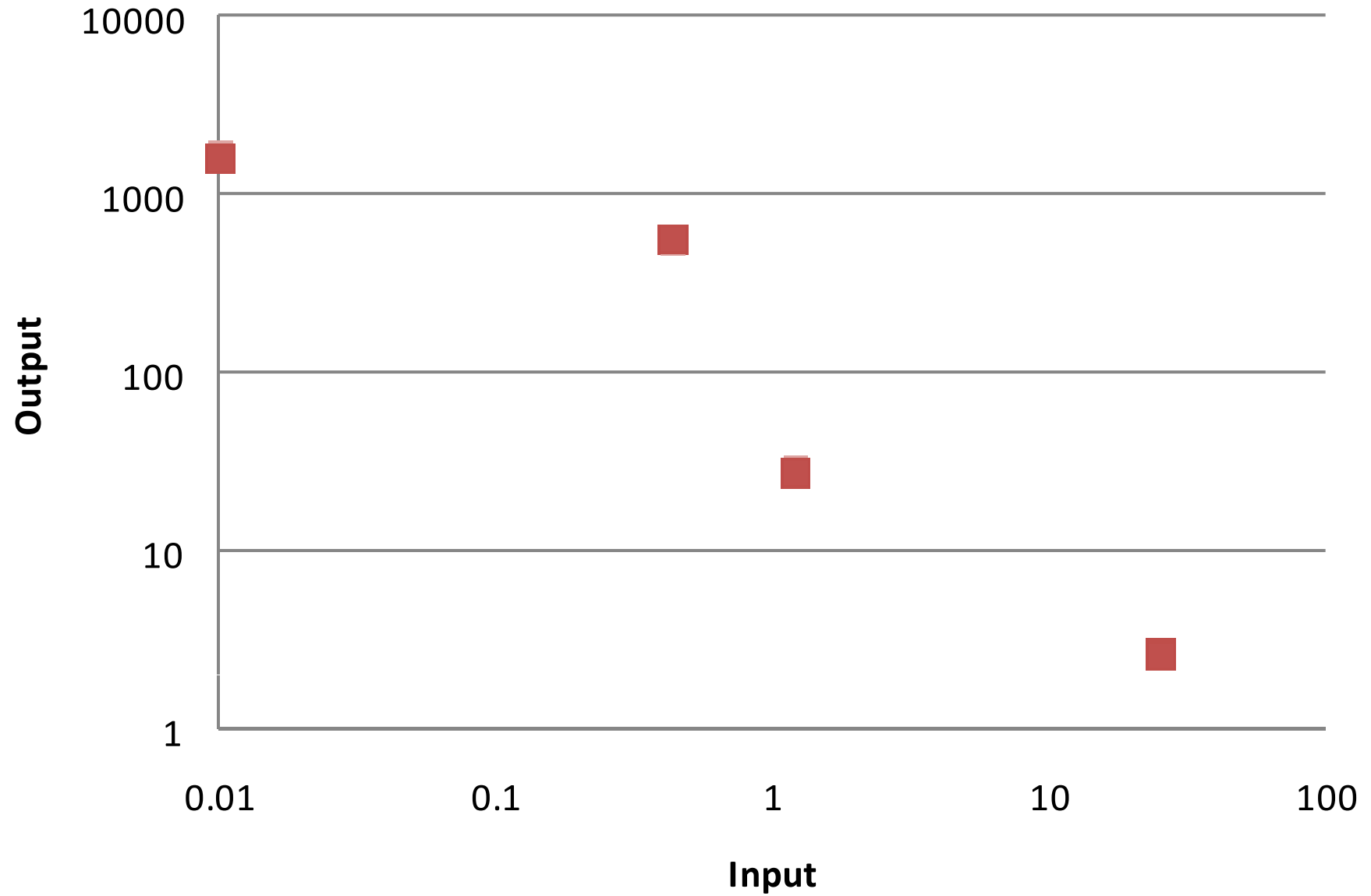



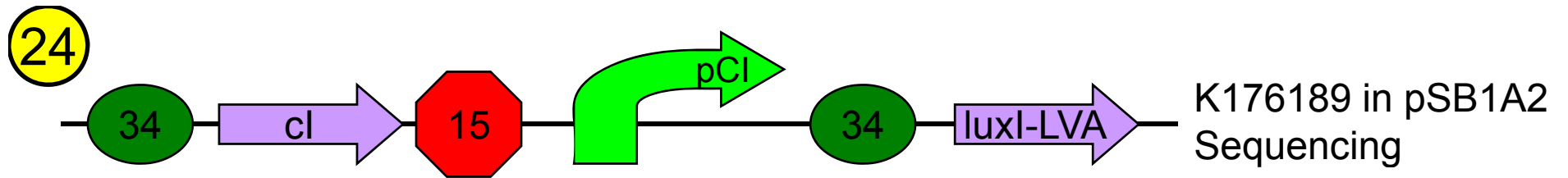

25



K103001 in pSB1A2  
Sequencing



K176190 fragment  
PCR



K176190 X+P  
Length OK



K176190 in pSB1A3  
Sequencing

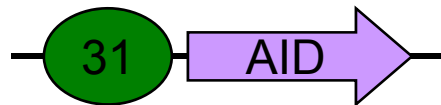

K176191 in pSB1A2  
Sequencing

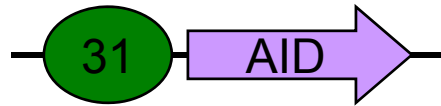

K176191 E+S  
Length OK

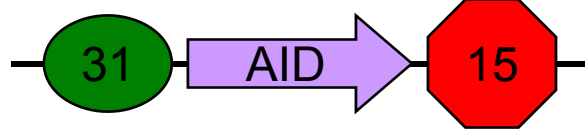

K176222 in pSB1AK3  
Sequencing

26

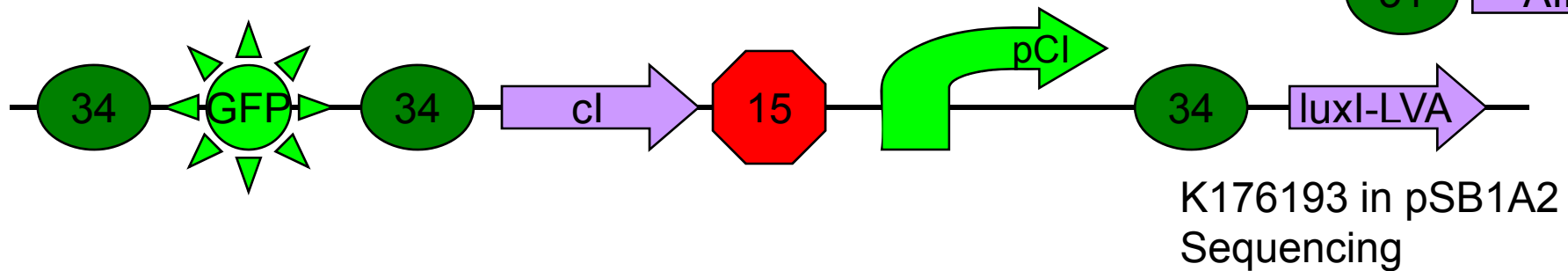
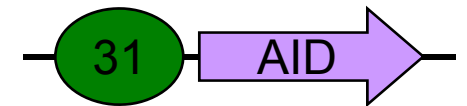
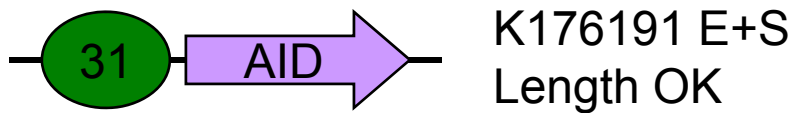
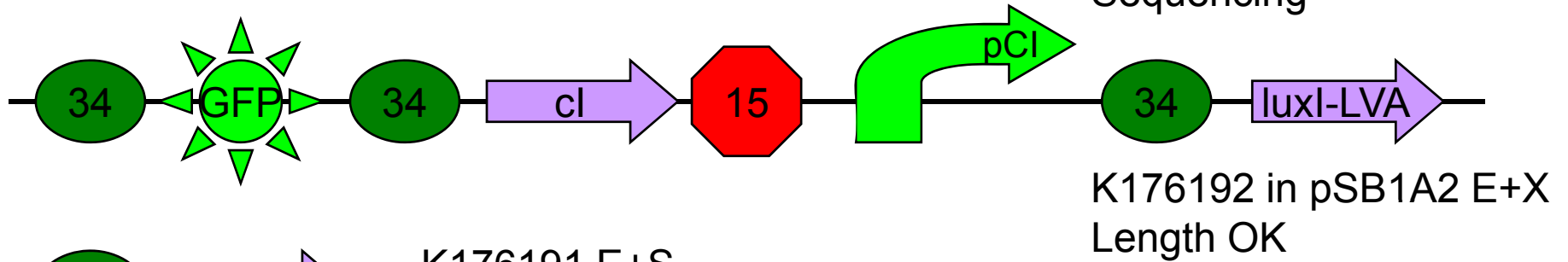
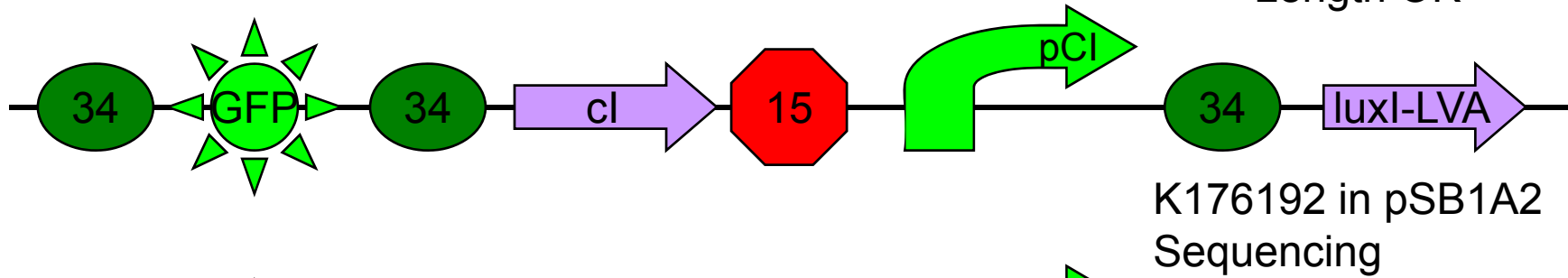
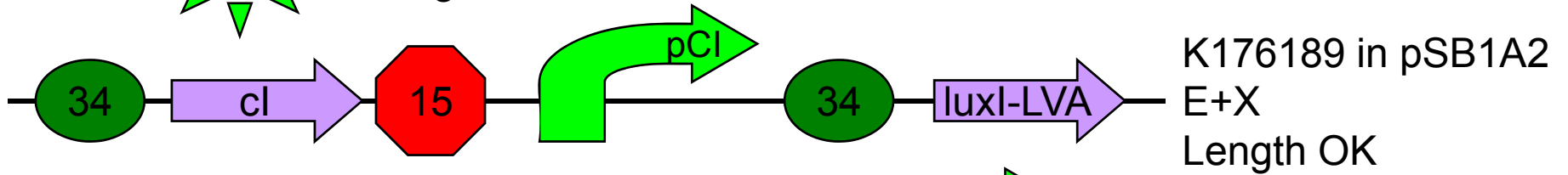
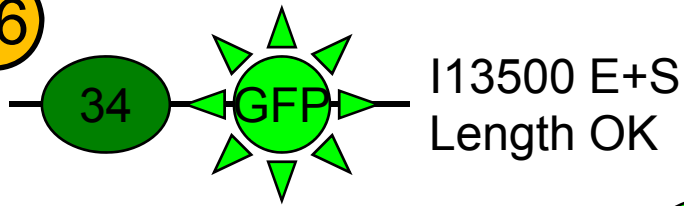

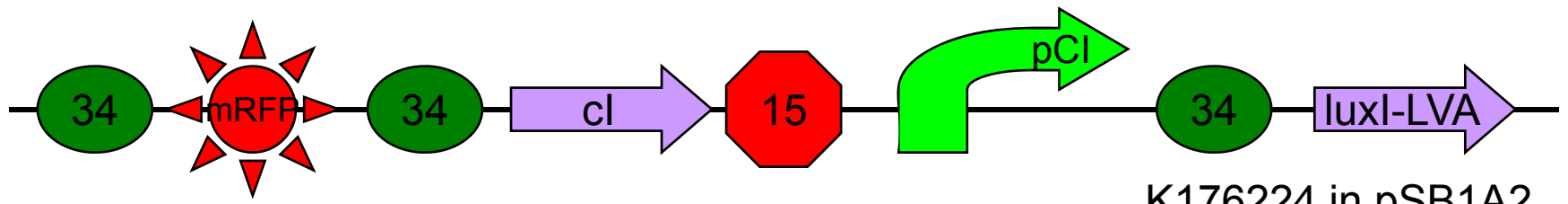

K176224 in pSB1A2  
Sequencing

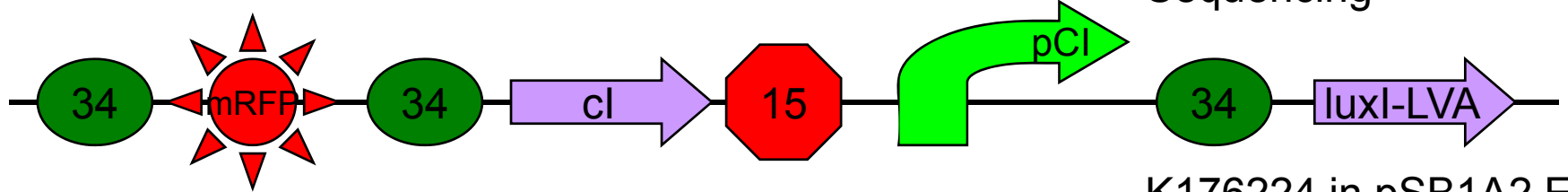

K176224 in pSB1A2 E+X  
Length OK

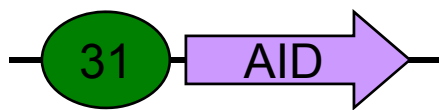

K176191 E+S  
Length OK

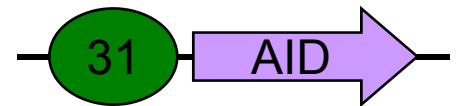

K176225 in pSB1A2  
Sequencing

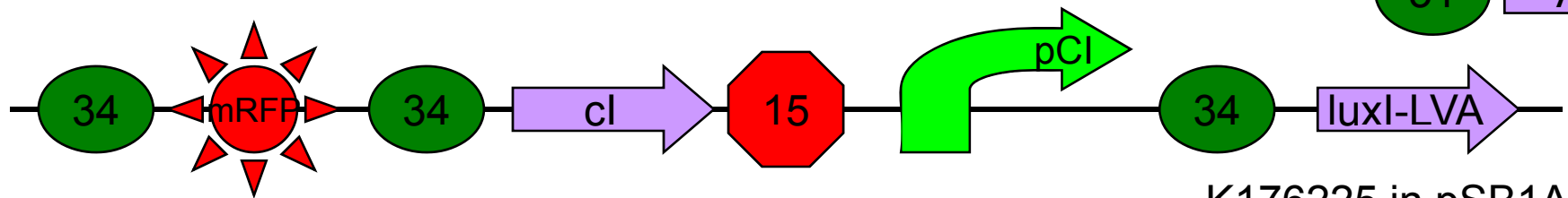





# Measurement

- Strain
  - TOP10
  - DH5 $\alpha$
  - MG1655
  - MDS 42 recA Blue
- Plasmid
- Medium
  - LB
  - M9
    - Minimal
    - Supplemented
  - EZ Rich Define
  - pH-buffered TBK
  - pH-buffered LBK
- pH
- Temperature
  - 37°C
  - 30°C
  - 34°C
- Pre-warm
- Shake
- Dilution
- Wash

# Wiki

- Team project description
- Notebook
  - Meetings
  - Lab Work
  - Sample Naming Sheets
- Logo
- Team
- Other pages



Thank You